

# COLDZ<sup>o</sup>NE

## HEAVY DUTY UNIT COOLER

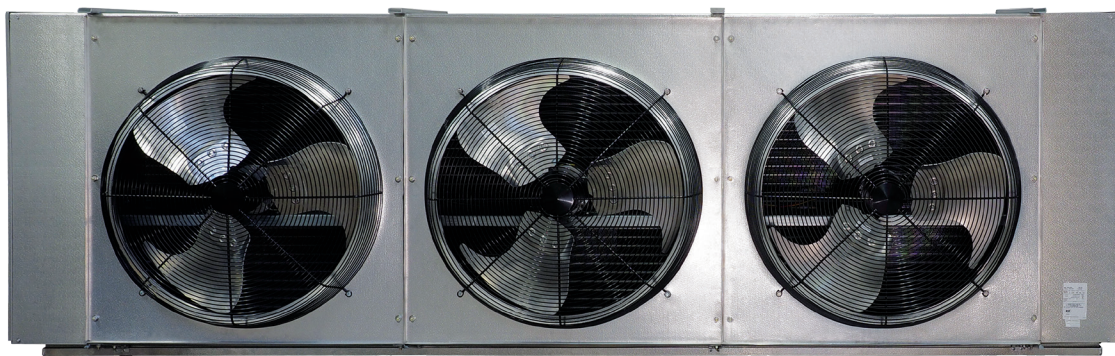

### Walk-Ins: Medium to Large Cooler and Freezer Applications

Designed for Walk-in Coolers and Freezers in boxes less than 3,000 Sq. Ft.

#### **Air Defrost**

31,200 to 253,100 BTUH

#### **Electric Defrost**

33,100 to 227,400 BTUH

#### **Hot Gas Defrost**

33,100 to 227,400 BTUH

## FEATURES

Russell's Heavy Duty Unit Coolers are the ideal evaporator solution for medium and large walk-in coolers and freezers. Designed with efficiency, performance and service in mind, the Heavy Duty Cooler line is optimized to cover Cold Storage applications in the most effective way. The Heavy Duty units were engineered to meet the Department of Energy's new AWEF performance regulations and feature energy-efficient rail-mount Dual Speed EC Motors.

All units are circuited for multiple refrigerants and feature optimized circuit patterns to maximize performance. Heavy Duty Unit Coolers have several enhanced service features including rail-mount motors, new high efficiency fan and venturi designs, enhanced surface coil tubing, easily removable fan guards and modular fan panels, face mount defrost heaters, hinged drain pans and shipping pallets designed to facilitate easy installation.

### SIZES

There are a wide array of sizes to match your specific application requirements ranging from 31,200 to 253,100 BTUH at a 10°TD. Models are available with air flow spanning a range of 5,750 to 24,000 CFM.

### HOUSING

Each unit is constructed with a rust-free, heavy gauge, textured, aluminum housing which is light weight yet extremely durable. Models feature hinged drain pans to allow for convenient servicing and maintenance. Pre-drilled hanger holes are provided on all units for fast installation.

### COIL

Seamless copper tubes are staggered and mechanically expanded into heavy gauge corrugated aluminum fins to assure maximum heat transfer. Die formed fin collars are provided for accurate fin spacing. Heavy gauge hangers are fastened directly to the tube sheet of the coil to provide high structural strength. Electric Defrost and Hot Gas Defrost Models are available in both 6 FPI and 4 FPI..

### MOTORS

Standard models feature highly efficient Dual Speed Electronically Commutated (EC) motors, which are compliant with California Title 24 regulations.

### FANS & FAN GUARDS

Powerful heavy-duty aluminum fans are individually balanced to provide vibration free operation. Standard heavy-gauge wire fan guards are UL/cUL-approved epoxy coated for corrosion resistance. Air throw for Heavy Duty Unit Coolers is 100 ft.

### REFRIGERANTS

Heavy Duty Unit Coolers are optimized for multiple refrigerants including R404A, R407A, R448A, R449A and R744 DX (CO2). Please specify system refrigerant requirements when ordering. A separate compartment is provided for all refrigerant connections which allows ample room for internal mounting of expansion valves.

### ELECTRIC DEFROST - LOW TEMP

Low Temperature Electric Defrost Models (RH6E or RH4E) are designed for use in freezers between +10°F and -30°F room temperatures. Defrost heaters are mounted on the air intake side of the unit for optimal performance and easy maintenance. A lower heater is installed inside the drain pan for fast, reliable drainage. Adjustable defrost termination, fan delay, and heater safety controls are factory-mounted for optimum performance of each control function.

### ELECTRIC DEFROST - MEDIUM TEMP

Medium Temperature Electric Defrost Models (RH6D) are designed for use in coolers between +11°F and +35°F room temperatures. Defrost heaters are mounted on the air intake side of the unit for optimal performance and easy maintenance. A lower Heater is installed inside the drain pan for fast, reliable drainage. Adjustable defrost termination, fan delay, and heater safety controls are factory-mounted for optimum performance of each control function.

### HOT GAS DEFROST

There are two types of Hot Gas Defrost models available: 3-pipe Hot Gas models (RH\*H or RH\*K) and 2-pipe Hot Gas Reverse Cycle units (RH\*G or RH\*L). Hot Gas Defrost 6 FPI models (RH6H, RH6K, RH6G, RH6L) are designed for use in coolers and freezers between 35°F and -30°F. Hot Gas Defrost 4 FPI models (RH4H, RH4K, RH4G, RH4L) are designed for use in freezers between 32°F and -30°F. All units include adjustable defrost termination and fan delay controls which are factory mounted for optimum performance of each control function. Refer to the current Russell Technical Bulletin for piping. Reverse Cycle units can also be used for Alternating Evaporator Systems.

### ELECTRICAL

Available in 208/230V/1, 208-230V/3, 460V/1 or 460/3. A large compartment is supplied for all electrical components and is easily accessible by removing the end panel. All models are UL and cUL listed.

### AIR DEFROST

Air Defrost models (RH6A) are designed for use in coolers at +35°F and warmer.

## OPTIONAL FEATURES

- EcoNet® Enabled Controller<sup>3</sup> (factory-installed)
- EcoNet® Command Center (loose)
- Reverse Connections
- Thermostat - Mechanical or Electric (mounted or loose)
- Thermostatic Expansion Valve (mounted or loose)
- Electronic Expansion Valve (mounted or loose)
- Liquid Line Solenoid Valve (mounted or loose)
- Insulated Drain Pan
- Painted Cabinet (White or Black)
- Stainless Steel Cabinet
- Coated Coil (Bronz-Glow, or Electrofin®)
- Suction/Liquid Heat Exchanger (loose)

### NOTES

- \* AWEF (Annual Walk-in Energy Factor)
1. Single Compressor system without variable capacity.
  2. Some limitations apply. For specific electrical offering, consult electrical data tables in this brochure.
  3. EcoNet Control Package includes: EEV; suction pressure transducer, suction entering air coil temp. thermistors, local on-board two-row backlit LCD display and push-button adjustments. (Controller replaces TXV, liquid line solenoid valve, room thermostat, defrost termination and fan delay, and time clock.)

## HIGHLIGHTED FEATURES AND OPTIONS



### FANS AND HOUSING

- 24" heavy duty aluminum fans are balanced for vibration-free operation
- High efficiency deep draw venturi provides optimal air flow
- Hinged end panels can be easily removed
- NSF approved



### COILS AND DEFROST HEATERS

- Available in 4 or 6 fins per inch (FPI)
- Electric defrost heaters are mounted on the air intake coil face to provide easy service access
- The drain pan heater is affixed to the drain pan and is easily accessed for service or cleaning

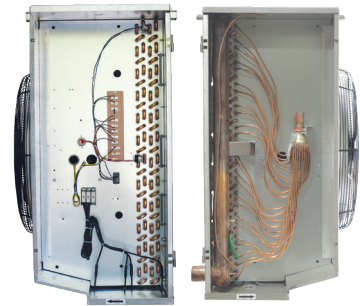

### ELECTRICAL AND PIPING

- End panels slide out for easy service from the front or sides of the unit
- Ample room in electrical and piping compartments for easy access



### ECONET ENABLED UNIT COOLERS (OPTIONAL)

- Developed in conjunction with Rheem Manufacturing specifically for walk-in coolers and freezers — it builds on the reliability and efficiency of Rheem's EcoNet technology
- Saves energy in refrigeration systems through precise superheat and space temperature control, fan cycling, and controlling how often the system goes into defrost based on compressor runtime
- Eliminates unnecessary defrosts
  - Maximizes energy efficiency with less compressor runtime
  - Reduces fan speed to 50% during off cycle for energy savings
- Can be used with a condensing unit in single and multiple evaporator installations as a group
- Optional **EcoNet Command Center** with intuitive graphical interface controls up to 32 devices (including the Command Center) through one display, provides continuous communication between system components, and the remote mount display allows for EcoNet Enabled Unit Coolers to be programmed, monitored and troubleshoot outside of the space being cooled.

## MODEL NOMENCLATURE

<u>R</u>	<u>H</u>	<u>6</u>	<u>E</u>	<u>109</u>	<u>D</u>	<u>D</u>	<u>A</u>
Brand	Style	Fins per Inch (FPI)	Defrost Type	BTUH in Thousands	Unit Voltage <sup>1</sup>	Motor Type	Vintage
R = Russell	H = Heavy Duty Y = Reverse Connections	4 / 6	A = Air E = Electric Defrost D = Medium Temp Electric Defrost H = Hot Gas 3-Pipe Electric Drain Pan G = Hot Gas Reverse Electric Drain Pan K = Hot Gas 3-Pipe Hot Gas Drain Pan L = Hot Gas Reverse Hot Gas Drain Pan		D = 208-230/1/60 E = 208-230/3/60 F = 460/1/60 G = 460/3/60	D = Dual Speed EC	

### EVAPORATOR APPLICATION RATINGS

Multiple conditions combine to determine the application capacity of an evaporator. Walk-in space temperature, relative humidity, saturated suction temperature difference, and outdoor ambient temperature. All of the factors are considered when calculating an evaporator application rating. These ratings are considerably higher than the net capacity value used for DOE ratings (AWEF).

The AWEF of an evaporator is calculated using the dry coil capacity and the daily evaporator power consumption. Power consumption included fan and defrost power. Evaporator net capacity reported to the DOE database is dry coil capacity less the full power fan watts. DOE test conditions are at 10°F evaporator/SST temperature difference and less than 50% relative humidity and 96°F liquid temperature. These conditions create a uniform test method, but should not be used for equipment selection. The equipment selected would be too large for the application.

Russell's published application ratings are a guideline for proper equipment selection. They account for true operating conditions experienced by equipment.

### FAN GUARDS EASILY REMOVABLE FOR QUICK ACCESS TO FAN BLADES AND RAIL-MOUNTED MOTORS

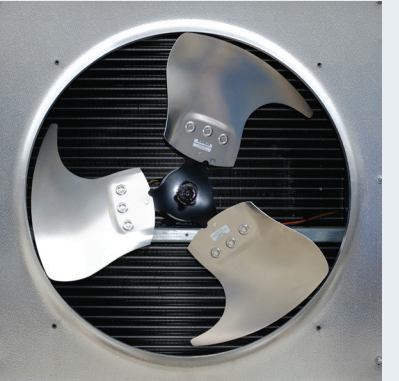
APPLICATION RATING AND ELECTRICAL DATA // AIR DEFROST MODELS

Model No.	BTUH Capacity @ +25°F S.T. & 10°F TD		CFM	No. of Fans	Total Fan Motor AMPS Dual Speed EC† Motors Motor Voltage	
	R404A/R744 DX (CO <sub>2</sub> )	R407A/R448A/ R449A <sup>^</sup>			208-230V/1	
					208-230V/1	460V/1
RH6A031*DA	31,200	36,600	5,920	1	6.3	6.3
RH6A043*DA	43,600	51,100	5,870			
RH6A052*DA	52,100	61,900	5,750			
RH6A063*DA	63,200	73,500	11,850	2	12.6	6.2
RH6A087*DA	87,900	103,500	11,730			
RH6A105*DA	105,200	124,900	11,500			
RH6A132*DA	132,500	155,800	17,600	3	18.9	9.3
RH6A156*DA	156,300	185,700	17,250			
RH6A175*DA	175,400	206,900	23,460			
RH6A209*DA	209,500	253,100	23,000	4	25.2	12.4

Model No.	208-230V/1				460V/1			
	MCA		MOPD		MCA		MOPD	
	Base Model	EcoNet Enabled <sup>2</sup>	Base Model	EcoNet Enabled <sup>2</sup>	Base Model	EcoNet Enabled <sup>2</sup>	Base Model	EcoNet Enabled <sup>2</sup>
RH6A031*DA	15.0	15.0	20	20	15.0	15.0	20	20
RH6A043*DA								
RH6A052*DA								
RH6A063*DA	15.0	16.2	20	20	15.0	15.0	20	20
RH6A087*DA								
RH6A105*DA								
RH6A132*DA	20.5	22.5	25	25	15.0	15.0	20	20
RH6A156*DA								
RH6A175*DA								
RH6A209*DA	26.8	28.8	30	30	15.0	15.0	20	20

NOTES:

- \* Each asterisk represents a variable character based on voltage ordered. See page 5 for nomenclature.
- <sup>^</sup> R407A, R448A and R449A are rated at dew point temperature. Use R407A capacity ratings for R407C and R407F.
- † Dual Speed EC motors are compliant with California Title 24 regulations.
- 2. EcoNet Enabled Units are not powered by Condensing Unit so Defrost Heaters are incorporated into shown MCA/MOPD. Models were designed in anticipation of the July 2020 Department of Energy Annual Walk-in Energy Factor (AWEF) regulations for evaporators for Walk-in Coolers and Freezers in boxes less than 3,000 sq. ft. See page 16 for AWEF compliance ratings.

APPLICATION RATING AND ELECTRICAL DATA // ELECTRIC DEFROST MODELS

Model No.	460V/3				Heater Amps			Heater Watts
	MCA		MOPD		460V/3			
	Base Model	EcoNet Enabled <sup>2</sup>	Base Model	EcoNet Enabled <sup>2</sup>	No. of Circuit	Amps Each Circuit	Total Heater Amps	
RH6E033GDA	15.0	15.0	20	20	1	7.5	7.5	6,000
RH6E044GDA								
RH6E053GDA								
RH6E066GDA	15.0	16.1	20	20	1	15.1	15.1	12,000
RH6E089GDA								
RH6E109GDA								
RH6E134GDA	15.0	23.6	20	25	1	22.6	22.6	18,000
RH6E163GDA								
RH6E199EGDA								
RH4E035GDA	15.0	15.0	20	20	1	7.5	7.5	6,000
RH4E044GDA								
RH4E071GDA								
RH4E087GDA	15.0	16.1	20	20	1	15.1	15.1	12,000
RH4E107GDA								
RH4E131GDA								
RH4E167GDA	15.0	31.1	20	35	1	30.1	30.1	24,000



SUPPORTS ARE BOLTED TO PALLET AND UNIT COOLER FOR PRODUCT SAFETY AND QUICKER INSTALLATION

NOTES:

- Capacity Correction for Low Temp Electric and Hot Gas Defrost Evaporators
 

S.S.T. (Dew):	20°F	0°F	-10°F	-20°F	-30°F	-40°F
Multiply Capacity by:	1.15	1.075	1.0375	1	0.9625	0.925
- EcoNet Enabled Units are not powered by Condensing Unit so Defrost Heaters are incorporated into shown MCA/MOPD.
- \* Each asterisk represents a variable character based on voltage ordered. See page 5 for nomenclature.
- † Dual Speed EC motors are compliant with California Title 24 regulations.
- <sup>^</sup> R407A, R448A and R449A are rated at dew point temperature. Use R407A capacity ratings for R407C and R407F. Models were designed in anticipation of the July 2020 Department of Energy Annual Walk-in Energy Factor (AWEF) regulations for evaporators for Walk-in Coolers and Freezers in boxes less than 3,000 sq. ft. See page 16 for AWEF compliance ratings.

APPLICATION RATING AND ELECTRICAL DATA // MEDIUM TEMP ELECTRIC DEFROST

Model No.	BTUH Capacity @ +25°F S.T. & 10°F TD		CFM	No. of Fans	Total Fan Motor AMPS Dual Speed EC† Motors Motor Voltage	
	R404A/R744DX (CO <sub>2</sub> )	R407A/R448A/ R449A^			208-230V/1	
					208-230V/1	460V/1
RH6D030*DA	31,200	36,600	5,920	1	6.3	3.1
RH6D042*DA	43,600	51,100	5,870			
RH6D051*DA	52,100	61,900	5,750			
RH6D062*DA	63,200	73,500	11,850	2	12.6	6.2
RH6D086*DA	87,900	103,500	11,730			
RH6D104*DA	105,200	124,900	11,500			
RH6D130*DA	132,500	155,800	17,600	3	18.9	9.3
RH6D155*DA	156,300	185,700	17,250			
RH6D174*DA	175,400	206,900	23,460			
RH6D208*DA	209,500	253,100	23,000	4	25.2	12.4

NOTES:

- \* Each asterisk represents a variable character based on voltage ordered. See page 5 for nomenclature.
- ^ R407A, R448A and R449A are rated at dew point temperature. Use R407A capacity ratings for R407C and R407F.
- † Dual Speed EC motors are compliant with California Title 24 regulations.

2. EcoNet Enabled Units are not powered by Condensing Unit so Defrost Heaters are incorporated into shown MCA/MOPD.

Models were designed in anticipation of the July 2020 Department of Energy Annual Walk-in Energy Factor (AWEF) regulations for evaporators for Walk-in Coolers and Freezers in boxes less than 3,000 sq. ft. See page 16 for AWEF compliance ratings.

APPLICATION RATING AND ELECTRICAL DATA // MEDIUM TEMP ELECTRIC DEFROST

Model No.	208-230V/3				Heater Amps			Heater Watts
	MCA		MOPD		208-230V/3			
	Base Model	EcoNet Enabled <sup>2</sup>	Base Model	EcoNet Enabled <sup>2</sup>	No. of Circuits	Amps per Circuit	Total Heater Amps	
RH6D030EDA	15.0	20.5	20	20	1	14.4	14.4	6,000
RH6D042EDA								
RH6D051EDA								
RH6D062EDA	15.0	30.9	20	35	1	28.9	28.9	12,000
RH6D086EDA								
RH6D104EDA								
RH6D130EDA	20.5	45.3	25	50	1	43.3	43.3	18,000
RH6D155EDA								
RH6D174EDA	26.8	59.7	30	60	2	28.9	57.7	24,000
RH6D208EDA								

Model No.	460V/3				Heater Amps			Heater Watts
	MCA		MOPD		460V/3			
	Base Model	EcoNet Enabled <sup>2</sup>	Base Model	EcoNet Enabled <sup>2</sup>	No. of Circuits	Amps per Circuit	Total Heater Amps	
RH6D030GDA	15.0	15.0	20	20	1	7.5	7.5	6,000
RH6D042GDA								
RH6D051GDA								
RH6D062GDA	15.0	16.1	20	20	1	15.1	15.1	12,000
RH6D086GDA								
RH6D104GDA								
RH6D130GDA	15.0	23.6	20	25	1	22.6	22.6	18,000
RH6D155GDA								
RH6D174GDA	15.0	31.1	20	35	1	30.1	30.1	24,000
RH6D208GDA								

NOTES:

- \* Each asterisk represents a variable character based on voltage ordered. See page 5 for nomenclature.
- ^ R407A, R448A and R449A are rated at dew point temperature. Use R407A capacity ratings for R407C and R407F.
- † Dual Speed EC motors are compliant with California Title 24 regulations.

2. EcoNet Enabled Units are not powered by Condensing Unit so Defrost Heaters are incorporated into shown MCA/MOPD.

Models were designed in anticipation of the July 2020 Department of Energy Annual Walk-in Energy Factor (AWEF) regulations for evaporators for Walk-in Coolers and Freezers in boxes less than 3,000 sq. ft. See page 16 for AWEF compliance ratings.

APPLICATION RATING AND ELECTRIC DATA // HOT GAS 3-PIPE DEFROST

	Hot Gas 3-Pipe Model No. (RH*H, RH*K)	BTUH Capacity @ -20°F S.T. & 10°F TD <sup>1</sup>		CFM	No. of Fans	Total Fan Motor Amps Dual Speed EC Motors		MCA	
		R404A	R407A/R448A/R449A <sup>^</sup>			208-230V/1	460V/1	208-230V/1	460V/1
		<b>6 FPI</b>							
	RH6*033*DA	33,100	38,700	5,920	1	6.3	3.1	15.0	15.0
	RH6*044*DA	44,500	50,900	5,870					
	RH6*053*DA	53,800	62,100	5,750					
	RH6*066*DA	66,400	76,600	11,850	2	12.6	6.2	15.0	15.0
	RH6*089*DA	89,400	102,300	11,730					
	RH6*109*DA	109,200	125,700	11,500					
	RH6*134*DA	134,500	153,800	17,600	3	18.9	9.3	20.5	15.0
	RH6*163*DA	163,500	188,800	17,250					
	RH6*199*DA	199,100	227,400	23,000					
<b>4 FPI</b>									
	RH4*035*DA	35,800	41,100	5,870	1	6.3	3.1	15.0	15.0
	RH4*044*DA	44,000	50,800	5,750					
	RH4*071*DA	71,400	83,000	11,730	2	12.6	6.2	15.0	15.0
	RH4*087*DA	87,400	100,900	11,500					
	RH4*107*DA	107,700	122,900	17,600	3	18.9	9.3	20.5	15.0
	RH4*131*DA	131,900	152,300	17,250					
	RH4*167*DA	167,000	190,200	23,000					

APPLICATION RATING AND ELECTRICAL DATA // HOT GAS REVERSE CYCLE

	Hot Gas 2-Pipe Model No. (RH*H, RH*K)	BTUH Capacity @ -20°F S.T. & 10°F TD <sup>1</sup>		CFM	No. of Fans	Total Fan Motor AMPS Dual Speed EC Motors <sup>†</sup>		MCA	
		R404A	R407A/R448A/R449A <sup>^</sup>			208-230V/1	460V/1	208-230V/1	460V/1
		<b>6 FPI</b>							
	RH6*033*DA	33,100	38,700	5,920	1	6.3	3.1	15.0	15.0
	RH6*044*DA	44,500	50,900	5,870					
	RH6*053*DA	53,800	62,100	5,750					
	RH6*066*DA	66,400	76,600	11,850	2	12.6	6.2	15.0	15.0
	RH6*089*DA	89,400	102,300	11,730					
	RH6*109*DA	109,200	125,700	11,500					
	RH6*134*DA	134,500	153,800	17,600	3	18.9	9.3	20.5	15.0
	RH6*163*DA	163,500	188,800	17,250					
	RH6*199*DA	199,100	227,400	23,000					
<b>4 FPI</b>									
	RH4*035*DA	35,800	41,100	5,870	1	6.3	3.1	15.0	15.0
	RH4*044*DA	44,000	50,800	5,750					
	RH4*071*DA	71,400	83,000	11,730	2	12.6	6.2	15.0	15.0
	RH4*087*DA	87,400	100,900	11,500					
	RH4*107*DA	107,700	122,900	17,600	3	18.9	9.3	20.5	15.0
	RH4*131*DA	131,900	152,300	17,250					
	RH4*167*DA	167,000	190,200	23,000					

	Hot Gas 3-Pipe Model No. (RH*H, RH*K)	MOPD		Electric Drain Pan Heater Amps		Heater Watts
		208-230V/1	460V/1	208-230V/1	460V/1	
		<b>6 FPI</b>				
	RH6*033*DA					2,000
	RH6*044*DA	20	20	8.3	4.3	2,000
	RH6*053*DA					
	RH6*066*DA					
	RH6*089*DA	20	20	16.7	8.7	4,000
	RH6*109*DA					
	RH6*134*DA	25	20	25.0	13.0	6,000
	RH6*163*DA					
	RH6*199*DA	30	20	33.3	17.4	8,000
<b>4 FPI</b>						
	RH4*035*DA	20	20	8.3	4.3	2,000
	RH4*044*DA					
	RH4*071*DA	20	20	16.7	8.7	4,000
	RH4*087*DA					
	RH4*107*DA	25	20	25.0	13.0	6,000
	RH4*131*DA					
	RH4*167*DA	30	20	33.3	17.4	8,000

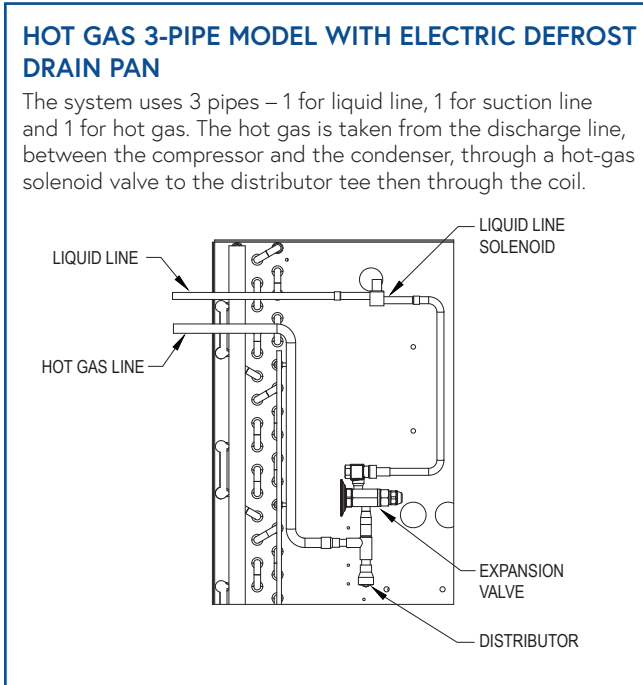

Each asterisk represents a variable character based on defrost and voltage ordered. Hot Gas 3-Pipe Version (H: Hot Gas Defrost 3-Pipe with Electric Drain Pan Heater, K: Hot Gas Defrost 3-Pipe with Hot Gas Drain Pan). See page 5 for nomenclature.

1. Note from page 7, Hot gas includes Electric Defrost Drain Pan

	Hot Gas 2-Pipe Model No. (RH*H, RH*K)	MOPD		Electric Drain Pan Heater Amps		Heater Watts
		208-230V/1	460V/1	208-230V/1	460V/1	
		<b>6 FPI</b>				
	RH6*033*DA					2,000
	RH6*044*DA	20	20	8.3	4.3	2,000
	RH6*053*DA					
	RH6*066*DA					
	RH6*089*DA	20	20	16.7	8.7	4,000
	RH6*109*DA					
	RH6*134*DA	25	20	25.0	13.0	6,000
	RH6*163*DA					
	RH6*199*DA	30	20	33.3	17.4	8,000
<b>4 FPI</b>						
	RH4*035*DA	20	20	8.3	4.3	2,000
	RH4*044*DA					
	RH4*071*DA	20	20	16.7	8.7	4,000
	RH4*087*DA					
	RH4*107*DA	25	20	25.0	13.0	6,000
	RH4*131*DA					
	RH4*167*DA	30	20	33.3	17.4	8,000

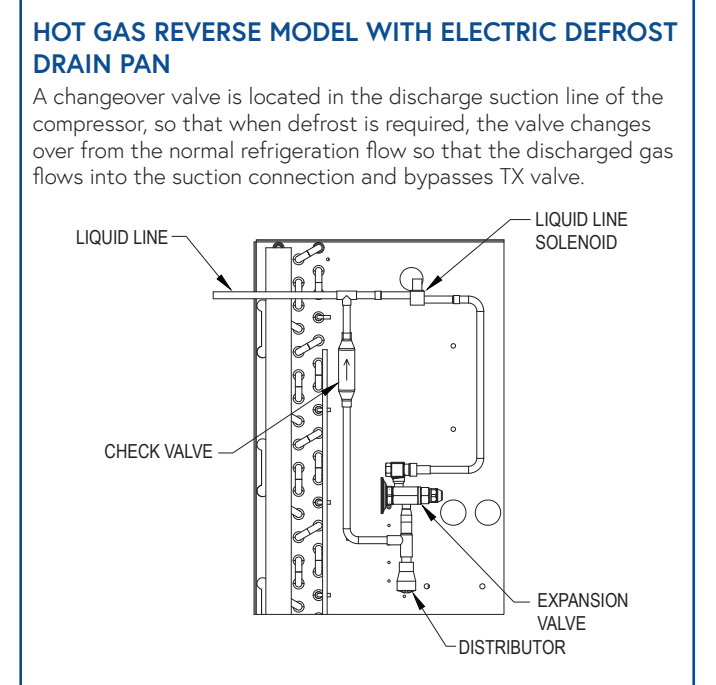

Each asterisk represents a variable character based on defrost and voltage ordered. Hot Gas 3-Pipe Version (H: Hot Gas Defrost 3-Pipe with Electric Drain Pan Heater, K: Hot Gas Defrost 3-Pipe with Hot Gas Drain Pan). See page 5 for nomenclature.

1. Note from page 7, Hot gas includes Electric Defrost Drain Pan

DISTRIBUTOR NOZZLE AND EXPANSION VALVES // AIR DEFROST MODELS

Model No.	Part Numbers						No. of Circuits	
	Nozzle at Liq. Temp.		TXV <sup>^</sup> at Liq. Temp.		EEV at Liq. Temp.			
	50°F	100°F	50°F	100°F	50°F	100°F		
<b>R404A</b>								
6 FPI	RH6A031*DA	G-1-1/2	G-4	SBFSE-B-C	SBFSE-C-C	SER-C	SER-C	6
	RH6A043*DA	G-1-1/2	G-5	SBFSE-C-C	OSE-6-C	SER-C	SER-C	
	RH6A052*DA	E-2	E-6	SBFSE-C-C	OSE-6-C	SER-C	SER-D	12
	RH6A063*DA	E-2-1/2	E-10	OSE-6-C	OSE-6-C	SER-C	SER-D	9
	RH6A087*DA	C-3	C-12	OSE-6-C	OSE-9-C	SER-D	SER-D	
	RH6A105*DA	C-4	C-15	OSE-9-C	OSE-9-C	SER-D	SERI-F	18
	RH6A132*DA	C-5	C-20	OSE-9-C	OSE-12-C	SER-D	SERI-F	
	RH6A156*DA	C-6	C-25	OSE-9-C	OSE-12-C	SERI-F	SERI-G	24
	RH6A175*DA	A-8	A-25	OSE-12-C	OSE-21-C	SERI-F	SERI-G	27
	RH6A209*DA	A-10	A-30	OSE-12-C	OSE-21-C	SERI-F	SERI-G	36
<b>R407A/ R448A/ R449A<sup>†</sup></b>								
6 FPI	RH6A031*DA	G-1-1/2	G-4	SBFDE-B-C	SBFDE-C-C	SER-B	SER-C	6
	RH6A043*DA	G-1-1/2	G-5	SBFDE-C-C	SBFDE-C-C	SER-C	SER-C	
	RH6A052*DA	E-2	E-6	SBFDE-C-C	EBSDE-7-C	SER-C	SER-C	12
	RH6A063*DA	E-2-1/2	E-10	SBFDE-C-C	EBSDE-7-C	SER-C	SER-D	9
	RH6A087*DA	C-3	C-12	EBSDE-7-C	EBSDE-10-C	SER-D	SER-D	
	RH6A105*DA	C-4	C-15	EBSDE-7-C	ODE-12-C	SER-D	SERI-F	18
	RH6A132*DA	C-5	C-17	EBSDE-10-C	ODE-12-C	SER-D	SERI-F	
	RH6A156*DA	C-6	C-20	EBSDE-12-C	ODE-17-C	SERI-F	SERI-F	24
	RH6A175*DA	A-8	A-25	EBSDE-12-C	ODE-17-C	SERI-F	SERI-G	27
	RH6A209*DA	A-10	A-30	EBSDE-17-C	ODE-28-C	SERI-F	SERI-G	36

Note: The distributor lines are 1/4" tube & 31" long.  
 \* Each asterisk represents a variable character based on voltage ordered. See page 4 for nomenclature.  
<sup>^</sup> TXV selections are based on +25°F suction temp., 8°F to 12°F evaporator TD. Contact factory for operating conditions outside of this range.  
<sup>†</sup> SBFDE, ODE, and EBSDE expansion valves are compatible with R407A, R448A and R449A/B. For other valves, follow manufacturers selection guidelines.  
 Base models (no factory-mounted components) include nozzles sized for 100°F liquid shipped loose.



Russell's Heavy Duty Unit Cooler can be used in combination with Next-Gen II Condensing Units to provide complete refrigeration solutions for medium and large walk-ins less than 3,000 sq. ft.

DISTRIBUTOR NOZZLE AND EXPANSION VALVES // ELECTRIC DEFROST

Model No.	Part Numbers						No. of Circuits		
	Nozzle at Liq. Temp.		TXV <sup>^</sup> at Liq. Temp.		EEV at Liq. Temp.				
	50°F	100°F	50°F	100°F	50°F	100°F			
<b>R404A</b>									
6 FPI	RH6E033*DA	E-3	E-8	SBFSE-C-Z	EBSSE-6-Z	SER-C	SER-C	9	
	RH6E044*DA	E-4	E-10	OSE-6-Z	EBSSE-7-1/2-Z	SER-C	SER-C		
	RH6E053*DA	E-5	E-12	OSE-6-Z	EBSSE-10-Z	SER-C	SER-D	12	
	RH6E066*DA	C-6	C-17	OSE-6-Z	EBSSE-10-Z	SER-C	SER-D	18	
	RH6E089*DA	C-10	C-20	OSE-9-Z	EBSSE-13-Z	SER-D	SER-D		
	RH6E109*DA	C-12	C-25	OSE-12-Z	OSE-21-Z	SER-D	SERI-F	24	
	RH6E134*DA	A-15	A-35	OSE-12-Z	OSE-30-Z	SER-D	SERI-F	27	
	RH6E163*DA	A-17	A-40	OSE-21-Z	OSE-30-Z	SERI-F	SERI-G		
	RH6E199*DA	A-20	A-50	OSE-35-Z	OSE-45-Z	SERI-F	SERI-G	36	
	4 FPI	RH4E035*DA	E-3	E-8	SBFSE-C-Z	OSE-6-Z	SER-C	SER-C	9
RH4E044*DA		E-4	E-12	OSE-6-Z	OSE-6-Z	SER-C	SER-C	12	
RH4E071*DA		C-8	C-17	OSE-6-Z	OSE-12-Z	SER-C	SER-D	18	
RH4E087*DA		C-10	C-20	OSE-9-Z	OSE-12-Z	SER-D	SER-D	24	
RH4E107*DA		A-12	A-30	OSE-12-Z	OSE-21-Z	SER-D	SERI-F	27	
RH4E131*DA		A-15	A-35	OSE-12-Z	OSE-30-Z	SER-D	SERI-F	36	
RH4E167*DA		A-20	A-40	OSE-21-Z	OSE-30-Z	SERI-F	SERI-G		
<b>R407A/ R448A/ R449A<sup>†</sup></b>									
6 FPI		RH6E033*DA	E-2-1/2	E-6	SBFDE-C-Z	ODE-7-Z	SER-B	SER-C	9
		RH6E044*DA	E-4	E-8	EBSDE-7-Z	ODE-12-Z	SER-C	SER-C	
	RH6E053*DA	E-5	E-12	EBSDE-7-Z	ODE-12-Z	SER-C	SER-C	12	
	RH6E066*DA	C-6	C-15	EBSDE-10-Z	ODE-12-Z	SER-C	SER-D	18	
	RH6E089*DA	C-8	C-17	ODE-12-Z	ODE-17-Z	SER-D	SER-D		
	RH6E109*DA	C-12	C-25	ODE-17-Z	ODE-28-Z	SER-D	SER-D	24	
	RH6E134*DA	A-15	A-30	ODE-17-Z	ODE-28-Z	SER-D	SERI-F	27	
	RH6E163*DA	A-17	A-35	ODE-28-Z	ODE-40-Z	SERI-F	SERI-G		
	RH6E199*DA	A-20	A-40	ODE-28-Z	ODE-45-Z	SERI-F	SERI-G	36	
	4 FPI	RH4E035*DA	E-3	E-6	SBFDE-C-Z	ODE-7-Z	SER-C	SER-C	9
RH4E044*DA		E-4	E-8	SBFDE-C-Z	ODE-7-Z	SER-C	SER-C	12	
RH4E071*DA		C-6	C-15	ODE-12-Z	ODE-12-Z	SER-C	SER-D	18	
RH4E087*DA		C-8	C-17	ODE-12-Z	ODE-17-Z	SER-D	SER-D	24	
RH4E107*DA		A-12	A-20	ODE-17-Z	ODE-28-Z	SER-D	SER-D	27	
RH4E131*DA		A-15	A-30	ODE-17-Z	ODE-28-Z	SER-D	SERI-F	36	
RH4E167*DA		A-17	A-35	ODE-28-Z	ODE-40-Z	SER-F	SERI-G		

NOTES:  
 The distributor lines are 1/4" tube & 31" long.  
 \* Each asterisk represents a variable character based on voltage ordered. See page 5 for nomenclature.  
<sup>^</sup> TXV selections are based on -20°F suction temp., 8°F to 12°F evaporator TD. Contact factory for operating conditions outside of this range.  
<sup>†</sup> SBFDE, ODE, and EBSDE expansion valves are compatible with R407A, R448A and R449A/B. For other valves, follow manufacturers selection guidelines.  
 Base models (no factory-mounted components) include nozzles sized for 100°F liquid shipped loose.

**DISTRIBUTOR NOZZLE AND EXPANSION VALVES // MED TEMP ELECTRIC DEFROST**

	Model No.	Part Numbers						No. of Circuits
		Nozzle at Liq. Temp.		TXV at Liq. Temp.		EEV at Liq. Temp.		
		50°F	100°F	50°F	100°F	50°F	100°F	
<b>R404A</b>								
6 FPI	RH6D030*DA	G-1-1/2	G-4	SBFSE-B-C	SBFSE-C-C	SER-C	SER-C	6
	RH6D042*DA	G-1-1/2	G-5	SBFSE-B-C	OSE-6-C	SER-C	SER-C	
	RH6D051*DA	E-2	E-6	SBFSE-B-C	OSE-6-C	SER-C	SER-D	12
	RH6D062*DA	E-2-1/2	E-10	OSE-6-C	OSE-6-C	SER-C	SER-D	9
	RH6D086*DA	C-3	C-12	OSE-6-C	OSE-9-C	SER-D	SER-D	18
	RH6D104*DA	C-4	C-15	OSE-9-C	OSE-9-C	SER-D	SERI-F	
	RH6D130*DA	C-5	C-20	OSE-9-C	OSE-12-C	SER-D	SERI-F	
	RH6D155*DA	C-6	C-25	OSE-9-C	OSE-12-C	SERI-F	SERI-G	24
	RH6D174*DA	A-8	A-25	OSE-12-C	OSE-21-C	SERI-F	SERI-G	27
	RH6D208*DA	A-10	A-30	OSE-12-C	OSE-21-C	SERI-F	SERI-G	36
<b>R448A/R449A/ R407A</b>								
6 FPI	RH6D030*DA	G-1-1/2	G-4	SBFDE-B-C	SBFDE-C-C	SER-B	SER-C	6
	RH6D042*DA	G-1-1/2	G-5	SBFDE-C-C	SBFDE-C-C	SER-C	SER-C	
	RH6D051*DA	E-2	E-6	SBFDE-C-C	EBSDE-7-C	SER-C	SER-C	12
	RH6D062*DA	E-2-1/2	E-8	SBFDE-C-C	EBSDE-7-C	SER-C	SER-D	9
	RH6D086*DA	C-4	C-12	EBSDE-7-C	EBSDE-10-C	SER-D	SER-D	18
	RH6D104*DA	C-4	C-15	EBSDE-7-C	ODE-12-C	SER-D	SERI-F	
	RH6D130*DA	C-5	C-17	EBSDE-10-C	ODE-12-C	SER-D	SERI-F	
	RH6D155*DA	C-6	C-20	EBSDE-12-C	ODE-17-C	SERI-F	SERI-F	24
RH6D174*DA	A-8	A-25	EBSDE-12-C	ODE-17-C	SERI-F	SERI-G	27	
RH6D208*DA	A-10	A-30	EBSDE-17-C	ODE-28-C	SERI-F	SERI-G	36	

**DISTRIBUTOR NOZZLE AND EXPANSION VALVES // HOT GAS DEFROST**

	Model No. RH*H/RH*G/ RH*K/RH*L	Part Numbers						No. of Circuits
		Nozzle at Liq. Temp.		TXV <sup>^</sup> at Liq. Temp.		EEV at Liq. Temp.		
		50°F	100°F	50°F	100°F	50°F	100°F	
<b>R404A</b>								
6 FPI	RH6E033*DA	E-3	E-8	SBFSE-C-Z	EBSSE-6-Z	SER-C	SER-C	9
	RH6E044*DA	E-4	E-10	OSE-6-Z	EBSSE-7-1/2-Z	SER-C	SER-C	
	RH6E053*DA	E-5	E-12	OSE-6-Z	EBSSE-10-Z	SER-C	SER-D	12
	RH6E066*DA	C-6	C-17	OSE-6-Z	EBSSE-10-Z	SER-C	SER-D	18
	RH6E089*DA	C-10	C-20	OSE-9-Z	EBSSE-13-Z	SER-D	SER-D	
	RH6E109*DA	C-12	C-25	OSE-12-Z	OSE-21-Z	SER-D	SERI-F	24
	RH6E134*DA	A-15	A-35	OSE-12-Z	OSE-30-Z	SER-D	SERI-F	27
	RH6E163*DA	A-17	A-40	OSE-21-Z	OSE-30-Z	SERI-F	SERI-G	
	RH6E199*DA	A-20	A-50	OSE-35-Z	OSE-45-Z	SERI-F	SERI-G	36
	4 FPI	RH4E035*DA	E-3	E-8	SBFSE-C-Z	OSE-6-Z	SER-C	SER-C
RH4E044*DA		E-4	E-12	OSE-6-Z	OSE-6-Z	SER-C	SER-C	12
RH4E071*DA		C-8	C-17	OSE-6-Z	OSE-12-Z	SER-C	SER-D	18
RH4E087*DA		C-10	C-20	OSE-9-Z	OSE-12-Z	SER-D	SER-D	24
RH4E107*DA		A-12	A-30	OSE-12-Z	OSE-21-Z	SER-D	SERI-F	27
RH4E131*DA		A-15	A-35	OSE-12-Z	OSE-30-Z	SER-D	SERI-F	36
RH4E167*DA		A-20	A-40	OSE-21-Z	OSE-30-Z	SERI-F	SERI-G	
<b>R407A/ R448A/ R449A<sup>†</sup></b>								
6 FPI	RH6E033*DA	E-2-1/2	E-6	SBFDE-C-Z	ODE-7-Z	SER-B	SER-C	9
	RH6E044*DA	E-4	E-8	EBSDE-7-Z	ODE-12-Z	SER-C	SER-C	
	RH6E053*DA	E-5	E-12	EBSDE-7-Z	ODE-12-Z	SER-C	SER-C	12
	RH6E066*DA	C-6	C-15	EBSDE-10-Z	ODE-12-Z	SER-C	SER-D	18
	RH6E089*DA	C-8	C-17	ODE-12-Z	ODE-17-Z	SER-D	SER-D	
	RH6E109*DA	C-12	C-25	ODE-17-Z	ODE-28-Z	SER-D	SER-D	24
	RH6E134*DA	A-15	A-30	ODE-17-Z	ODE-28-Z	SER-D	SERI-F	27
	RH6E163*DA	A-17	A-35	ODE-28-Z	ODE-40-Z	SERI-F	SERI-G	
RH6E199*DA	A-20	A-40	ODE-28-Z	ODE-45-Z	SERI-F	SERI-G	36	
4 FPI	RH4E035*DA	E-3	E-6	SBFDE-C-Z	ODE-7-Z	SER-C	SER-C	9
	RH4E044*DA	E-4	E-8	SBFDE-C-Z	ODE-7-Z	SER-C	SER-C	12
	RH4E071*DA	C-6	C-15	ODE-12-Z	ODE-12-Z	SER-C	SER-D	18
	RH4E087*DA	C-8	C-17	ODE-12-Z	ODE-17-Z	SER-D	SER-D	24
	RH4E107*DA	A-12	A-20	ODE-17-Z	ODE-28-Z	SER-D	SER-D	27
	RH4E131*DA	A-15	A-30	ODE-17-Z	ODE-28-Z	SERI-D	SERI-F	36
	RH4E167*DA	A-17	A-35	ODE-28-Z	ODE-40-Z	SERI-F	SERI-G	

**NOTES:**

The distributor lines are 1/4" tube & 21" long.

\* Each asterisk represents a variable character based on voltage ordered. See page 4 for nomenclature.

<sup>^</sup> TXV selections for Hot Gas Defrost Models are based on -20°F suction temp., 8°F to 12°F evaporator TD. Contact factory for operating conditions outside of this range. Do not use pressure limiting TXVs when the condensing unit includes a CPR valve.

<sup>†</sup> SBFDE, EBSDE, and ODE expansion valves are compatible with R407A, R448A and R449A/B. For other valves, follow manufacturers selection guidelines.

Base models (no factory-mounted components) include nozzles sized for 100°F liquid shipped loose.



**SPECIFICATIONS // AIR DEFROST MODELS**

	Model No.	Fan Dia. (Inches)	Motor Data			Refrigerant Connections		No. of Hanger Slot Locations	Fig.	Unit Dimensions (Inches)			Approx. Unit Wt. (Lbs.)
			Motor Qty.	HP	RPM	Liquid Line <sup>^</sup>	Suction			L	W	H	
6 FPI	RH6E033*DA	30	1	3/4	850	1/2	1-1/8	4	1	59-7/8	27-3/8	49-1/4	293
	RH6E044*DA	30	1	3/4	850	1/2	1-3/8	4	1	59-7/8	27-3/8	49-1/4	293
	RH6E053*DA	30	1	3/4	850	5/8	1-5/8	4	1	59-7/8	27-3/8	49-1/4	293
	RH6E066*DA	30	2	3/4	850	5/8	1-5/8	6	2	99-7/8	27-3/8	49-1/4	489
	RH6E089*DA	30	2	3/4	850	7/8	2-1/8	6	2	99-7/8	27-3/8	49-1/4	489
	RH6E109*DA	30	2	3/4	850	7/8	2-1/8	6	2	99-7/8	27-3/8	49-1/4	489
	RH6E134*DA	30	3	3/4	850	7/8	2-1/8	8	3	139-7/8	27-3/8	49-1/4	652
	RH6E163*DA	30	3	3/4	850	1-1/8	2-1/8	8	3	139-7/8	27-3/8	49-1/4	652
	RH6E199*DA	30	4	3/4	850	1-1/8	2-1/8	8	3	179-7/8	27-3/8	49-1/4	837
RH6A209*DA	30	4	3/4	850	1-1/8	2-1/8	8	3	179-7/8	27-3/8	49-1/4	837	

**NOTES:**

- \* Each asterisk represents a variable character based on voltage ordered. See page 4 for nomenclature.
- <sup>^</sup> For units with mounted TXV components. See Nozzle/TXV table for distributor connection size when TXV is field installed.
- 1. For dimensional distance between hanger slots, consult model's corresponding dimension drawing. Hanger slots are 1/2" deep x 1" wide.
- 2. Drain is 1-1/4" NPT for all models.
- + If the model has a numerical value in the AWEF table below, the following statement applies: "The refrigeration system is designed and certified for use in walk-in cooler applications less than 3,000 sq. ft."

Shipping Information - All Models				
No. of Fans	Shipping Dimensions (Inches)			Approx. Unit Wt. (Lbs.)
	L	W	H	
1	69	42	66	470
2	109	42	66	730
3	146	42	66	1,000
4	189	42	66	1,130

Department of Energy Annual Walk-In Energy Factor (AWEF) Ratings		
Model Number	FPI	AWEF
<b>Cooler Models - Air Defrost</b>		
R*6A031*DA	6	9.0
R*6A043*DA	6	9.0
R*6A052*DA	6	9.0
R*6A063*DA	6	9.0
R*6A087*DA	6	9.0
R*6A105*DA	6	9.0
R*6A132*DA	6	9.0
R*6A156*DA	6	9.0
R*6A175*DA	6	9.0
R*6A209*DA	6	9.0

**SPECIFICATIONS // ELECTRIC AND HOT GAS MODELS**

	Model No. RH*E/H/G/K/L	Fan Dia. (Inches)	Motor Data			Refrigerant Connections			No. of Hanger Slot Locations	Fig.	Unit Dimensions (Inches)			Approx. Unit Wt. (Lbs.)
			Motor Qty.	HP	RPM	Liquid Line <sup>^</sup>	Suction	3-Pipe Hot Gas Line			L	W	H	
6 FPI	RH6*033*DA	30	1	3/4	850	1/2	2-1/8	1-1/8	4	1	59-7/8	27-3/8	49-1/4	293
	RH6*044*DA	30	1	3/4	850	5/8	2-1/8	1-1/8	4	1	59-7/8	27-3/8	49-1/4	293
	RH6*053*DA	30	1	3/4	850	5/8	2-1/8	1-1/8	4	1	59-7/8	27-3/8	49-1/4	293
	RH6*066*DA	30	2	3/4	850	5/8	2-1/8	1-1/8	6	2	99-7/8	27-3/8	49-1/4	489
	RH6*089*DA	30	2	3/4	850	7/8	3-1/8	1-1/8	6	2	99-7/8	27-3/8	49-1/4	489
	RH6*109*DA	30	2	3/4	850	7/8	3-1/8	1-1/8	6	2	99-7/8	27-3/8	49-1/4	489
	RH6*134*DA	30	3	3/4	850	1-1/8	3-1/8	1-3/8	8	3	139-7/8	27-3/8	49-1/4	652
	RH6*163*DA	30	3	3/4	850	1-1/8	3-1/8	1-3/8	8	3	139-7/8	27-3/8	49-1/4	652
	RH6*199*DA	30	4	3/4	850	1-1/8	3-1/8	1-3/8	10	4	139-7/8	27-3/8	49-1/4	837
4 FPI	RH4*035*DA	30	1	3/4	850	1/2	2-1/8	1-1/8	4	1	59-7/8	27-3/8	49-1/4	293
	RH4*044*DA	30	1	3/4	850	5/8	2-1/8	1-1/8	4	1	59-7/8	27-3/8	49-1/4	293
	RH4*071*DA	30	2	3/4	850	5/8	2-1/8	1-1/8	6	2	99-7/8	27-3/8	49-1/4	489
	RH4*087*DA	30	2	3/4	850	7/8	3-1/8	1-1/8	6	2	99-7/8	27-3/8	49-1/4	489
	RH4*107*DA	30	3	3/4	850	7/8	3-1/8	1-3/8	8	3	139-7/8	27-3/8	49-1/4	652
	RH4*131*DA	30	3	3/4	850	1-1/8	3-1/8	1-3/8	8	3	139-7/8	27-3/8	49-1/4	652
	RH4*167*DA	30	4	3/4	850	1-1/8	3-1/8	1-3/8	10	4	179-7/8	27-3/8	49-1/4	837

Department of Energy Annual Walk-In Energy Factor (AWEF) Ratings		
Base Model No.	FPI	AWEF
<b>Cooler Models - Electric and Hot Gas Defrost</b>		
R*6*033*DA	6	9.0
R*6*044*DA	6	9.0
R*6*053*DA	6	9.0
R*6*066*DA	6	9.0
R*6*089*DA	6	9.0
R*6*109*DA	6	9.0
R*6*134*DA	6	9.0
R*6*163*DA	6	9.0
R*6*199*DA	6	9.0

Department of Energy Annual Walk-In Energy Factor (AWEF) Ratings		
Base Model No.	FPI	AWEF
<b>Freezer Models - Electric and Hot Gas Defrost</b>		
R*6*033*DA	6	4.15
R*6*044*DA	6	4.15
R*6*053*DA	6	4.15
R*6*066*DA	6	4.15
R*6*089*DA	6	4.15
R*6*109*DA	6	4.15
R*6*134*DA	6	4.15
R*6*163*DA	6	4.15
R*6*199*DA	6	4.15
R*4*035*DA	4	4.15
R*4*044*DA	4	4.15
R*4*071*DA	4	4.15
R*4*087*DA	4	4.15
R*4*107*DA	4	4.15
R*4*131*DA	4	4.15
R*4*167*DA	4	4.15

**NOTES:**

- \* Each asterisk represents a variable character based on voltage ordered. See page 5 for nomenclature.
- <sup>^</sup> For units with mounted TXV components. See Nozzle/TXV table for distributor connection size when TXV is field installed.
- 1. For dimensional distance between hanger slots, consult model's corresponding dimension drawing. Hanger slots are 1/2" deep x 1" wide.
- 2. Drain is 1-1/4" NPT for all models.
- 3. For shipping dimensions and weights, see Shipping Information table on page 15.
- + If the model has a numerical value in the table above, the following statement applies: "The refrigeration system is designed and certified for use in walk-in cooler applications less than 3,000 sq. ft."

**TYPICAL APPLICATIONS:**



Medium to Large Warehouses



Cold Storage Warehouses



Walk-in Coolers and Freezers

PHYSICAL DIMENSIONS

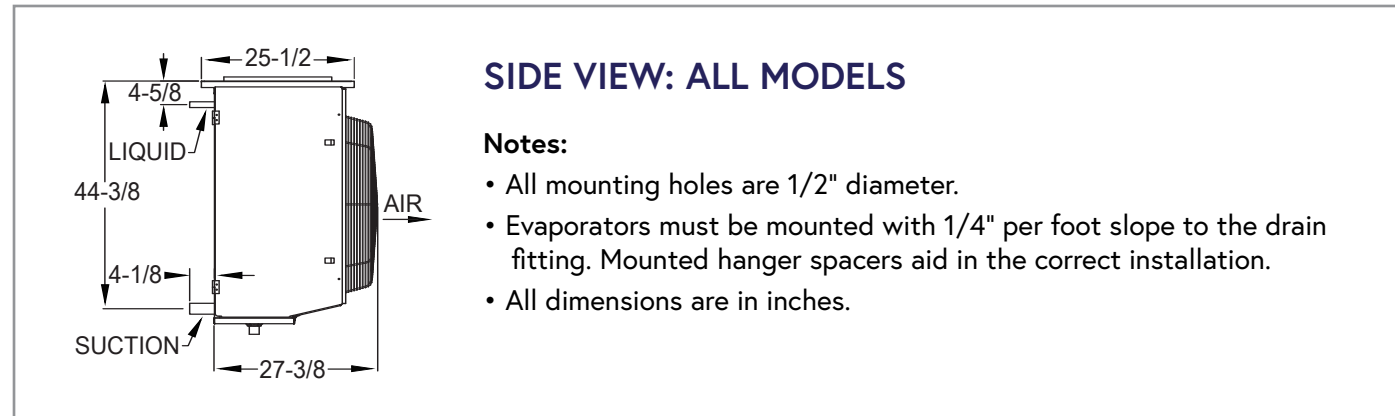

Figure 1: Single Fan

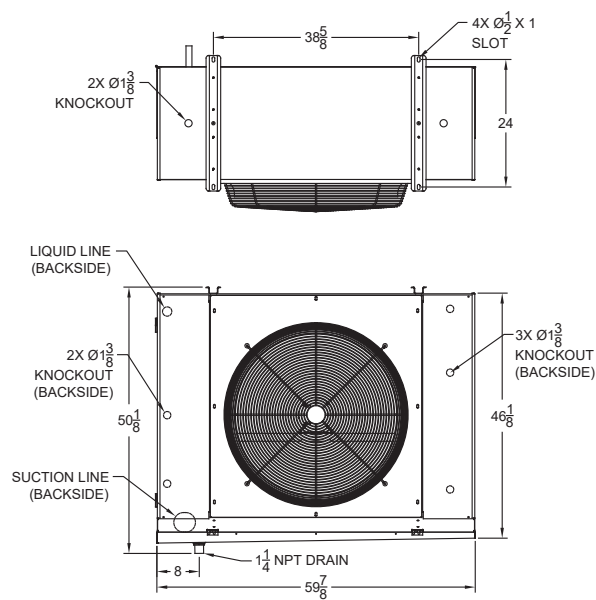
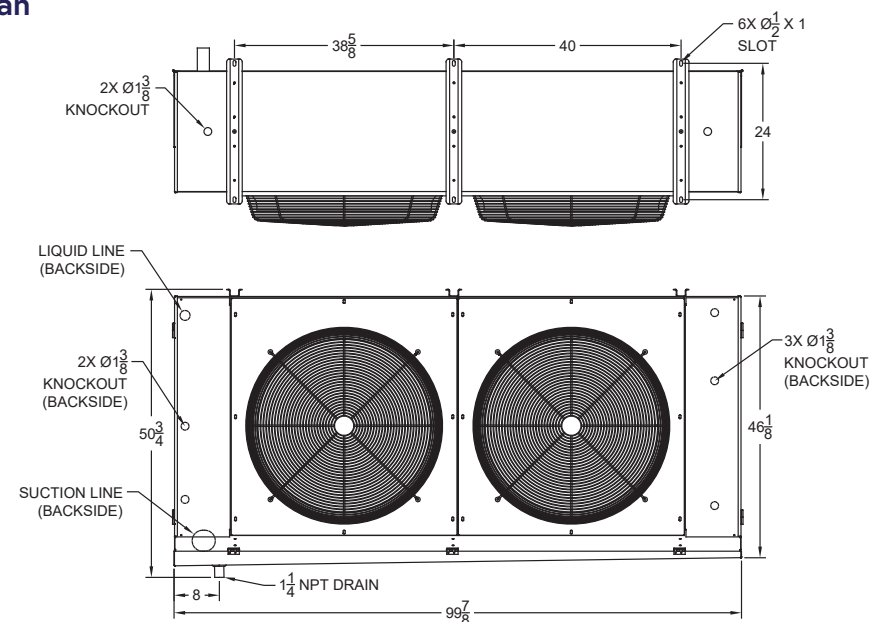

Figure 2: Two Fan



PHYSICAL DIMENSIONS

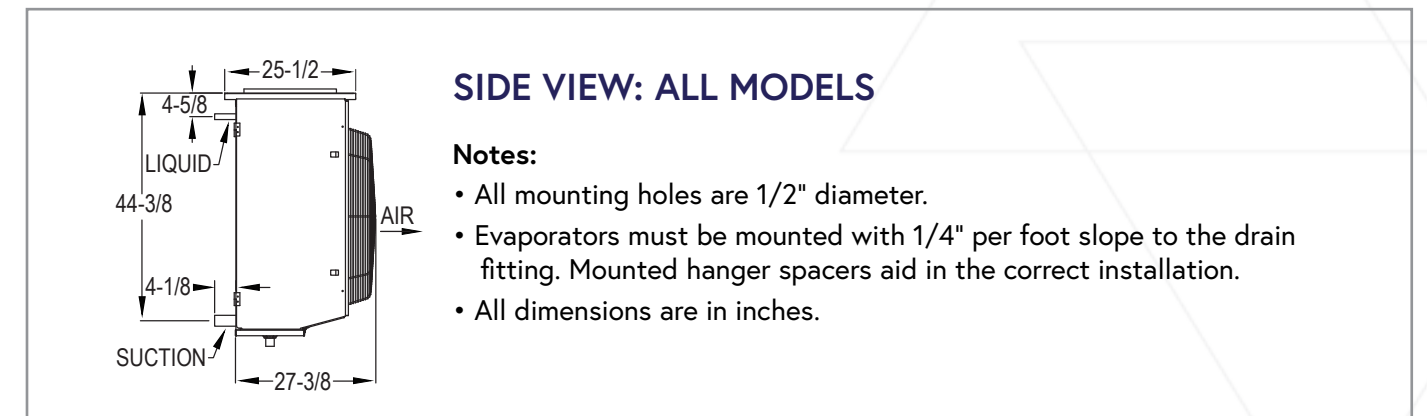

Figure 3: Three Fan

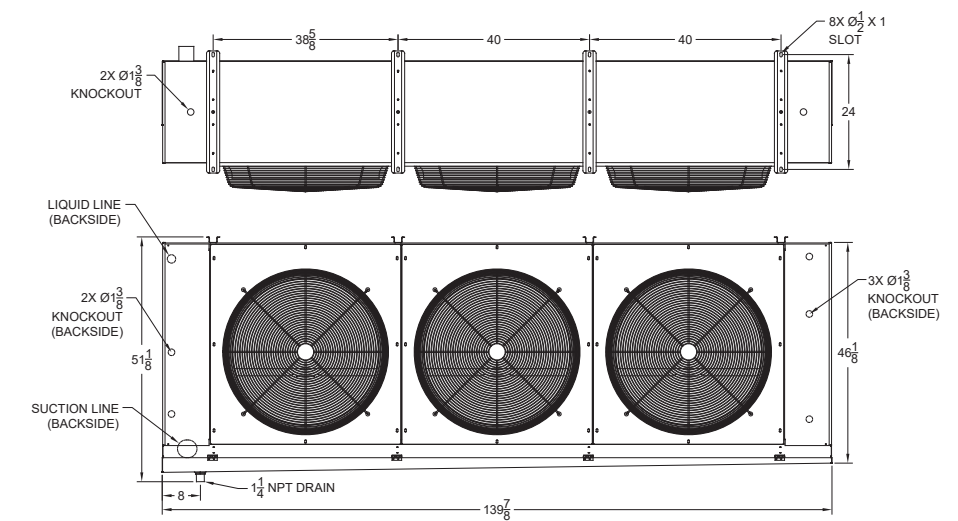
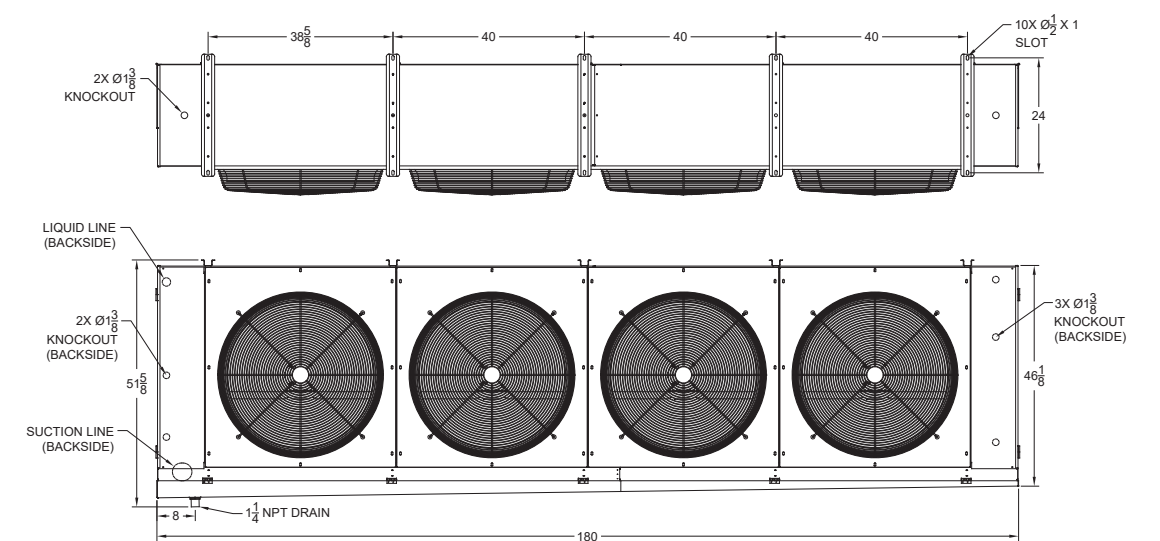

Figure 4: Four Fan



Due to continuing product development, specifications are subject to change without notice.

# COLDZ<sup>o</sup>NE

ENGINEERED FOR COOL.™

©2024 Heat Transfer Products Group  
Published April 2024  
CZ-CHX-0424  
[coldzone.htpg.com](http://coldzone.htpg.com)



This information is the most current and accurate information available and is subject to change without notice. HTPG makes no warranty or guarantee of any kind, express or implied, regarding the information set forth herein, including without limitation warranty regarding its currency, accuracy or completeness or any warranty of merchantability or fitness for a particular purpose.

