

COLDZ^oNE

WAREHOUSE UNIT COOLER

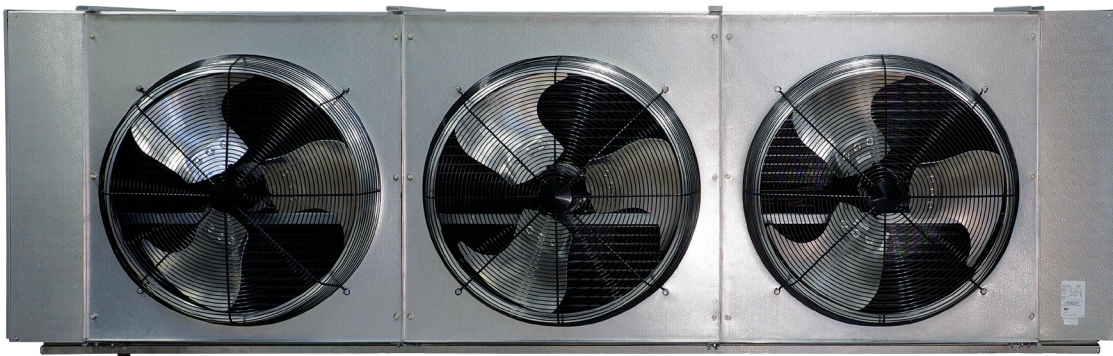

Walk-Ins: Medium to Large Cooler and Freezer Applications

Warehouse Unit Coolers are designed exclusively for applications 3,000 sq. ft. and larger.

Air Defrost

34,500 to 282,500 BTUH

Electric Defrost

36,400 to 246,100 BTUH

Hot Gas Defrost

36,400 to 246,100 BTUH

FEATURES

Our Warehouse Unit Coolers are the ideal evaporator solution for large walk-in coolers and freezers. Designed with efficiency, performance and service in mind, it's optimized to cover Cold Storage applications in the most effective way. They feature rail-mount three-phase motors with standard or high static pressure prop fan blades. All units are circuited for multiple refrigerants and feature optimized circuit patterns to maximize performance.

Warehouse Unit Coolers have several enhanced service features including new high efficiency fan and venturi designs, enhanced surface coil tubing, easily removable fan guards and modular fan panels, face mount defrost heaters, hinged drain pans and shipping pallets designed to facilitate easy installation.

WAREHOUSE MODELS ARE DESIGNED EXCLUSIVELY FOR USE IN WALK-IN COOLERS AND FREEZERS 3,000 SQ. FEET AND LARGER AND FALL OUTSIDE OF THE JULY 2020 DEPARTMENT OF ENERGY FACTOR (AWEF) REGULATIONS.

SIZES

There are a wide array of sizes to match your specific application requirements ranging from 34,500 to 282,500 BTUH at a 10°TD. Models are available with air flow spanning a range of 6,875 to 27,500 CFM.

HOUSING

Each unit is constructed with a rust-free, textured, aluminum housing which is light weight yet extremely durable. Models feature hinged drain pans to allow for convenient servicing and maintenance. Hanger holes are provided on all units for fast installation.

COIL

Seamless copper tubes are staggered and mechanically expanded into corrugated aluminum fins to assure maximum heat transfer. Die formed fin collars are provided for accurate fin spacing. Heavy gauge hangers are fastened directly to the tube sheet of the coil to provide high structural strength. Low Temp Electric Defrost and Hot Gas Defrost Models are available in both 6 FPI and 4 FPI. Medium Temp Electric Defrost and Air Defrost models are available in 6 FPI.

MOTORS

Models are offered with three-phase motors with standard or high static pressure prop fan blades.

FANS & FAN GUARDS

Powerful heavy-duty aluminum fans are individually balanced to provide vibration free operation. Standard heavy gauge wire fan guards are UL/cUL-approved epoxy coated for corrosion resistance. High-static pressure prop fan blades are also available. Air throw for Warehouse Unit Coolers is 120 ft. with standard fan. If you require a high-static fan prop in an application above freezing, please contact factory.

REFRIGERANTS

Warehouse Unit Coolers are optimized for multiple refrigerants including R404A, R407A, R448A, R449A and R744 DX (CO2). Please specify system refrigerant requirements when ordering. A separate compartment is provided for all refrigerant connections which allows ample room for internal mounting of expansion valves.

AIR DEFROST

Air Defrost models are designed for use in coolers at +35°F and warmer.

ELECTRIC DEFROST - MEDIUM TEMP

Medium Temperature Electric Defrost Models are designed for use in coolers between +10°F and +35°F. Defrost heaters are mounted on the air intake side of the unit for optimal performance and easy maintenance. An additional heater is installed inside the drain pan for fast, reliable drainage. Adjustable defrost termination, fan delay and heater safety controls are factory mounted for optimum performance of each control function.

ELECTRIC DEFROST - LOW TEMP

Low Temperature Electric Defrost Models are designed for use in freezers between +9°F and -30°F. Defrost heaters are mounted on the air intake side of the unit for optimal performance and easy maintenance. An additional heater is installed inside the drain pan for fast, reliable drainage. Adjustable defrost termination, fan delay and heater safety controls are factory mounted for optimum performance of each control function.

HOT GAS DEFROST

There are two types of Hot Gas Defrost models available: a 3-pipe Hot Gas models or a 2-Pipe Hot Gas Reverse Cycle units. Additionally, each type of hot gas defrost model is also available with either a hot gas loop in the drain pan or an electric heater in the drain pan. Hot Gas Defrost 6 FPI models are designed for use in coolers and freezers between 35°F and -30°F, and Hot Gas Defrost 4 FPI models are designed for use in freezers between 32°F and -30°F. All Hot gas models include adjustable defrost termination and fan delay controls, which are factory mounted for optimum performance of each control function. Refer to the current Russell Technical Bulletin for piping. Reverse Cycle units can also be used for Alternating Evaporator Systems.

ELECTRICAL

Available in 208-230V/3 or 460/3. A large compartment is supplied for all electrical components and is easily accessible by removing the end panel. All models are UL and cUL listed.

OPTIONAL FEATURES

- EcoNet® Enabled Controller¹ (factory-installed) (Econet not available on Hot Gas Evaporators)
- EcoNet® Command Center (loose)
- Reverse Connections
- Thermostat - Mechanical or Electric (mounted or loose)
- Thermostatic Expansion Valve (mounted or loose)
- Electronic Expansion Valve (mounted or loose)
- Liquid Line Solenoid Valve (mounted or loose)
- Insulated Drain Pan
- Painted Cabinet (White or Black)
- Stainless Steel Cabinet
- Coated Coil (Bronz-Glow, or Electrofin®)
- Heat Exchanger (loose)

1. EcoNet Control Package includes: EEV, suction pressure transducer, suction entering air coil temp. thermistors, thru-the-door disconnect switch, local on-board two-row backlit LCD display and push-button adjustments. (Controller replaces TXV, liquid line solenoid valve, room thermostat, defrost termination, fan delay, and time clock.)

ECONET ENABLED UNIT COOLERS (OPTIONAL)

- Developed in conjunction with Rheem Manufacturing specifically for walk-in coolers and freezers — it builds on the reliability and efficiency of Rheem's EcoNet technology
- Saves energy in refrigeration systems through precise superheat and space temperature control, fan cycling, and controlling how often the system goes into defrost based on compressor runtime
- Eliminates unnecessary defrosts
- Maximizes energy efficiency with less compressor runtime
- Reduces fan speed to 50% during off cycle for energy savings
- Can be used with a condensing unit in single and multiple evaporator installations as a group
- Optional EcoNet Command Center with intuitive graphical interface controls up to 32 devices (including the Command Center) through one display, continuous communication between system components, and remote mount display allows for EcoNet Enabled Unit Coolers to be programmed, monitored and troubleshot outside of space being cooled.



MODEL NOMENCLATURE

C	W	6	E	143	E	T	A
Brand	Style	Fins per Inch (FPI)	Defrost Type	BTUH in Thousands	Unit Voltage ¹	Motor Type	Vintage
C = Coldzone	W = Warehouse Z = Opposite Hand W (LEFT)	4 FPI 6 FPI	A = Air D = Medium Temp Electric Defrost E = Low Temp Electric Defrost H = Hot Gas 3-Pipe with Electric Drain Pan G = Hot Gas Reverse with Electric Drain Pan K = Hot Gas 3-Pipe with Hot Gas Drain Pan L = Hot Gas Reverse with Hot Gas Drain Pan		E = 208-230/3/60 G = 460/3/60	T = Three Phase H = Three Phase with High-Static	

APPLICATION RATING & ELECTRICAL DATA // AIR DEFROST: 3-PHASE MOTOR

Model No.	BTUH Capacity @ 25°F S.T. & 10°F TD		CFM	No. of Fans	208-230V/3	460V/3	
	R404A/ R744 DX (CO ₂)	R407A/ R448A/R449A [^]			Total Fan Motor Amps		
6 FPI	CW6A034*TA	34,500	40,400	7,080	1	4.1	2.0
	CW6A047*TA	47,000	55,000	7,010	1	4.1	2.0
	CW6A058*TA	58,200	68,900	6,875	1	4.1	2.0
	CW6A069*TA	69,600	80,900	14,160	2	8.2	4.0
	CW6A094*TA	94,500	111,500	14,030	2	8.2	4.0
	CW6A117*TA	117,200	138,800	13,750	2	8.2	4.0
	CW6A143*TA	143,100	167,000	21,040	3	12.3	6.0
	CW6A176*TA	176,000	207,500	20,625	3	12.3	6.0
	CW6A190*TA	190,100	226,100	28,050	4	16.4	8.0
	CW6A234*TA	234,900	282,500	27,500	4	16.4	8.0

Model No.	208-230V/3				460V/3				
	Base Model		EcoNet Enabled ¹		Base Model		EcoNet Enabled ¹		
	MCA	MOPD	MCA	MOPD	MCA	MOPD	MCA	MOPD	
6 FPI	CW6A034*TA	15.0	20	15.0	20	15.0	20	15.0	20
	CW6A047*TA	15.0	20	15.0	20	15.0	20	15.0	20
	CW6A058*TA	15.0	20	15.0	20	15.0	20	15.0	20
	CW6A069*TA	15.0	20	15.0	20	15.0	20	15.0	20
	CW6A094*TA	15.0	20	15.0	20	15.0	20	15.0	20
	CW6A117*TA	15.0	20	15.0	20	15.0	20	15.0	20
	CW6A143*TA	15.0	20	15.0	20	15.0	20	15.0	20
	CW6A176*TA	15.0	20	15.0	20	15.0	20	15.0	20
	CW6A190*TA	17.4	20	19.4	20	15.0	20	15.0	20
	CW6A234*TA	17.4	20	19.4	20	15.0	20	15.0	20

* Each asterisk represents a variable character based on voltage ordered. See page 4 for nomenclature.

[^] R407A, R448A and R449A are rated at dew point temperature. Use R407A capacity ratings for R407C and R407F.

1. EcoNet Enabled Units are not powered by Condensing Unit so Defrost Heaters are incorporated into shown MCA/MOPD.

Econet Enabled Calculation includes a minimum 1 Amp for control voltages.

6 WAREHOUSE UNIT COOLER

APPLICATION RATING & ELECTRICAL DATA // MEDIUM TEMPERATURE ELECTRIC DEFROST: 3-PHASE MOTOR

Model No.		BTUH Capacity @ +25F ST & +10F TD ¹		CFM	No. of Fans	208-230V/3	460V/3
		R404A/ R744 DX (CO ₂)	R407A/ R448A/R449A [^]			Total Fan Motor Amps	
6 FPI	CW6D033*TA	34,500	40,400	7080	1	4.1	2.0
	CW6D046*TA	47,000	55,000	7010	1	4.1	2.0
	CW6D057*TA	58,200	68,900	6875	1	4.1	2.0
	CW6D068*TA	69,600	80,900	14160	2	8.2	4.0
	CW6D093*TA	94,500	111,500	14030	2	8.2	4.0
	CW6D116*TA	117,200	138,800	13750	2	8.2	4.0
	CW6D142*TA	143,100	167,000	21040	3	12.3	6.0
	CW6D175*TA	176,000	207,500	20625	3	12.3	6.0
	CW6D189*TA	190,100	226,100	28050	4	16.4	8.0
	CW6D233*TA	234,900	282,500	27500	4	16.4	8.0

Model No.		BTUH Capacity @ +25F ST & +10F TD ¹		CFM	No. of Fans	208-230V/3	460V/3
		R404A/ R744 DX (CO ₂)	R407A/ R448A/R449A [^]			Total Fan Motor Amps	
4 FPI	CW4D029*TA	30,500	35,800	7080	1	4.1	2.0
	CW4D041*TA	41,600	48,700	7010	1	4.1	2.0
	CW4D050*TA	51,500	61,000	6875	1	4.1	2.0
	CW4D060*TA	61,600	71,600	14160	2	8.2	4.0
	CW4D082*TA	83,600	98,700	14030	2	8.2	4.0
	CW4D103*TA	103,700	122,800	13750	2	8.2	4.0
	CW4D126*TA	126,600	148,800	21040	3	12.3	6.0
	CW4D155*TA	155,800	183,600	20625	3	12.3	6.0
	CW4D167*TA	168,200	200,100	28050	4	16.4	8.0
	CW4D206*TA	207,900	250,000	27500	4	16.4	8.0

Capacity Correction for Medium Temperature Electric

SST (Dew)	35°F	25°F	20°F	15°F	10°F
Multiply Capacity by:	1.0375	1	0.98	0.96	0.94

* Each asterisk represents a variable character based on voltage ordered. See page 4 for nomenclature.

[^] R407A, R448A and R449A are rated at dew point temperature. Use R407A capacity ratings for R407C and R407F.

APPLICATION RATING & ELECTRICAL DATA // MEDIUM TEMPERATURE ELECTRIC DEFROST: 3-PHASE MOTOR

Model No.		208-230V/3							Heater Watts
		Base Model		EcoNet Enabled ²		Heater Amps			
		MCA	MOPD	MCA	MOPD	No. of Circuits	Amps Each Circuit	Total Heater Amps	
6 FPI	CW6D033ETA	15.0	20	16.4	20	1	14.4	14.4	6,000
	CW6D046ETA	15.0	20	16.4	20	1	14.4	14.4	6,000
	CW6D057ETA	15.0	20	16.4	20	1	14.4	14.4	6,000
	CW6D068ETA	15.0	20	30.9	35	1	28.9	28.9	12,000
	CW6D093ETA	15.0	20	30.9	35	1	28.9	28.9	12,000
	CW6D116ETA	15.0	20	30.9	35	1	28.9	28.9	12,000
	CW6D142ETA	15.0	20	45.3	50	1	43.3	43.3	18,000
	CW6D175ETA	15.0	20	45.3	50	1	43.3	43.3	18,000
	CW6D189ETA	17.4	20	59.7	60	2	28.9	57.7	24,000
CW6D233ETA	17.4	20	59.7	60	2	28.9	57.7	24,000	

Model No.		208-230V/3							Heater Watts
		Base Model		EcoNet Enabled ²		Heater Amps			
		MCA	MOPD	MCA	MOPD	No. of Circuits	Amps Each Circuit	Total Heater Amps	
4 FPI	CW4D029ETA	15.0	20	16.4	16.4	1	14.4	14.4	6,000
	CW4D041ETA	15.0	20	16.4	16.4	1	14.4	14.4	6,000
	CW4D050ETA	15.0	20	16.4	16.4	1	14.4	14.4	6,000
	CW4D060ETA	15.0	20	30.9	35	1	28.9	28.9	12,000
	CW4D082ETA	15.0	20	30.9	35	1	28.9	28.9	12,000
	CW4D103ETA	15.0	20	30.9	35	1	28.9	28.9	12,000
	CW4D126ETA	15.0	20	45.3	50	1	43.3	43.3	18,000
	CW4D155ETA	15.0	20	45.3	50	1	43.3	43.3	18,000
	CW4D167ETA	17.4	20	59.7	60	2	28.9	57.7	24,000
	CW4D206ETA	17.4	20	59.7	60	2	28.9	57.7	24,000

2. Econet Enabled Calculation includes a minimum 1 Amp for control voltages.

EcoNet Enabled Units are not powered by Condensing Unit so Defrost Heaters are incorporated into shown MCA/MOPD.

8 WAREHOUSE UNIT COOLER

APPLICATION RATING & ELECTRICAL DATA // MEDIUM TEMPERATURE ELECTRIC DEFROST: 3-PHASE MOTOR

Model No.		460V/3							Heater Watts
		Base Model		EcoNet Enabled ²		Heater Amps			
		MCA	MOPD	MCA	MOPD	No. of Circuits	Amps Each Circuit	Total Heater Amps	
6 FPI	CW6D033GTA	15.0	20	15.0	20	1	7.5	7.5	6,000
	CW6D046GTA	15.0	20	15.0	20	1	7.5	7.5	6,000
	CW6D057GTA	15.0	20	15.0	20	1	7.5	7.5	6,000
	CW6D068GTA	15.0	20	16.1	20	1	15.1	15.1	12,000
	CW6D093GTA	15.0	20	16.1	20	1	15.1	15.1	12,000
	CW6D116GTA	15.0	20	16.1	20	1	15.1	15.1	12,000
	CW6D142GTA	15.0	20	23.6	25	1	22.6	22.6	18,000
	CW6D175GTA	15.0	20	23.6	25	1	22.6	22.6	18,000
	CW6D189GTA	15.0	20	31.1	35	1	30.1	30.1	24,000
	CW6D233GTA	15.0	20	31.1	35	1	30.1	30.1	24,000

Model No.		460V/3							Heater Watts
		Base Model		EcoNet Enabled ²		Heater Amps			
		MCA	MOPD	MCA	MOPD	No. of Circuits	Amps Each Circuit	Total Heater Amps	
4 FPI	CW4D029GTA	15.0	20	15.0	20	1	7.5	7.5	6,000
	CW4D041GTA	15.0	20	15.0	20	1	7.5	7.5	6,000
	CW4D050GTA	15.0	20	15.0	20	1	7.5	7.5	6,000
	CW4D060GTA	15.0	20	16.1	20	1	15.1	15.1	12,000
	CW4D082GTA	15.0	20	16.1	20	1	15.1	15.1	12,000
	CW4D103GTA	15.0	20	16.1	20	1	15.1	15.1	12,000
	CW4D126GTA	15.0	20	23.6	25	1	22.6	22.6	18,000
	CW4D155GTA	15.0	20	23.6	25	1	22.6	22.6	18,000
	CW4D167GTA	15.0	20	31.1	35	1	30.1	30.1	24,000
	CW4D206GTA	15.0	20	31.1	35	1	30.1	30.1	24,000

2. Econet Enabled Calculation includes a minimum 1 Amp for control voltages.

EcoNet Enabled Units are not powered by Condensing Unit so Defrost Heaters are incorporated into shown MCA/MOPD.

APPLICATION RATING & ELECTRICAL DATA // LOW TEMPERATURE ELECTRIC DEFROST: 3-PHASE MOTOR

Model No.	BTUH Capacity @ -20°F S.T. & 10°F TD ¹		CFM	No. of Fans	208-230V/3	460V/3	
	R404A/ R744 DX (CO ₂)	R407A/ R448A/R449A [^]			Total Fan Motor Amps		
6 FPI	CW6E036*TA	36,400	41,900	7,080	1	4.1	2.0
	CW6E047*TA	47,900	54,600	7,010	1	4.1	2.0
	CW6E059*TA	59,200	67,900	6,875	1	4.1	2.0
	CW6E072*TA	72,500	83,500	14,160	2	8.2	4.0
	CW6E096*TA	96,100	109,400	14,030	2	8.2	4.0
	CW6E120*TA	120,000	137,200	13,750	2	8.2	4.0
	CW6E143*TA	143,600	163,100	21,040	3	12.3	6.0
	CW6E179*TA	179,500	206,600	20,625	3	12.3	6.0
CW6E216*TA	216,200	246,100	27,500	4	16.4	8.0	

Model No.	BTUH Capacity @ -20°F S.T. & 10°F TD ¹		CFM	No. of Fans	208-230V/3	460V/3	
	R404A/ R744 DX (CO ₂)	R407A/ R448A/R449A [^]			Total Fan Motor Amps		
4 FPI	CW4E038*TA	38,300	43,600	7,010	1	4.1	2.0
	CW4E048*TA	48,900	56,000	6,875	1	4.1	2.0
	CW4E077*TA	77,300	88,600	14,030	2	8.2	4.0
	CW4E097*TA	97,000	111,000	13,750	2	8.2	4.0
	CW4E115*TA	115,600	131,200	21,040	3	12.3	6.0
	CW4E145*TA	145,700	166,400	20,625	3	12.3	6.0
	CW4E182*TA	182,200	206,500	27,500	4	16.4	8.0

Capacity Correction for Low Temp Electric and Hot Gas Defrost

SST (Dew)	0°F	-10°F	-20°F	-30°F	-40°F
Multiply Capacity by:	1.075	1.0375	1	0.9625	0.925

* Each asterisk represents a variable character based on voltage ordered. See page 4 for nomenclature.

[^] R407A, R448A and R449A are rated at dew point temperature. Use R407A capacity ratings for R407C and R407F.

10 WAREHOUSE UNIT COOLER

208-230V/3 DATA // LOW TEMPERATURE ELECTRIC DEFROST: 3-PHASE MOTOR

Model No.		208-230V/3							Heater Watts
		Base Model		EcoNet Enabled ²		Heater Amps			
		MCA	MOPD	MCA	MOPD	No. of Circuits	Amps Each Circuit	Total Heater Amps	
6 FPI	CW6E036ETA	15.0	20	16.4	20	1	14.4	14.4	6,000
	CW6E047ETA	15.0	20	16.4	20	1	14.4	14.4	6,000
	CW6E059ETA	15.0	20	16.4	20	1	14.4	14.4	6,000
	CW6E072ETA	15.0	20	30.9	35	1	28.9	28.9	12,000
	CW6E096ETA	15.0	20	30.9	35	1	28.9	28.9	12,000
	CW6E120ETA	15.0	20	30.9	35	1	28.9	28.9	12,000
	CW6E143ETA	15.0	20	45.3	50	1	43.3	43.3	18,000
	CW6E179ETA	15.0	20	45.3	50	1	43.3	43.3	18,000
	CW6E216ETA	17.4	20	59.7	60	2	28.9	57.7	24,000

Model No.		208-230V/3							Heater Watts
		Base Model		EcoNet Enabled ²		Heater Amps			
		MCA	MOPD	MCA	MOPD	No. of Circuits	Amps Each Circuit	Total Heater Amps	
4 FPI	CW4E038ETA	15.0	20	16.4	20	1	14.4	14.4	6,000
	CW4E048ETA	15.0	20	16.4	20	1	14.4	14.4	6,000
	CW4E077ETA	15.0	20	30.9	35	1	28.9	28.9	12,000
	CW4E097ETA	15.0	20	30.9	35	1	28.9	28.9	12,000
	CW4E115ETA	15.0	20	45.3	50	1	43.3	43.3	18,000
	CW4E145ETA	15.0	20	45.3	50	1	43.3	43.3	18,000
	CW4E182ETA	17.4	20	59.7	60	2	28.9	57.7	24,000

2. Econet Enabled Calculation includes a minimum 1 Amp for control voltages.

EcoNet Enabled Units are not powered by Condensing Unit so Defrost Heaters are incorporated into shown MCA/MOPD.

460V/3 DATA // LOW TEMPERATURE ELECTRIC DEFROST: 3-PHASE MOTOR

Model No.		460V/3							Heater Watts
		Base Model		EcoNet Enabled ²		Heater Amps			
		MCA	MOPD	MCA	MOPD	No. of Circuits	Amps Each Circuit	Total Heater Amps	
6 FPI	CW6E036GTA	15.0	20	15.0	20	1	7.5	7.5	6,000
	CW6E047GTA	15.0	20	15.0	20	1	7.5	7.5	6,000
	CW6E059GTA	15.0	20	15.0	20	1	7.5	7.5	6,000
	CW6E072GTA	15.0	20	16.1	20	1	15.1	15.1	12,000
	CW6E096GTA	15.0	20	16.1	20	1	15.1	15.1	12,000
	CW6E120GTA	15.0	20	16.1	20	1	15.1	15.1	12,000
	CW6E143GTA	15.0	20	23.6	25	1	22.6	22.6	18,000
	CW6E179GTA	15.0	20	23.6	25	1	22.6	22.6	18,000
	CW6E216GTA	15.0	20	31.1	35	1	30.1	30.1	24,000

Model No.		460V/3							Heater Watts
		Base Model		EcoNet Enabled ²		Heater Amps			
		MCA	MOPD	MCA	MOPD	No. of Circuits	Amps Each Circuit	Total Heater Amps	
4 FPI	CW4E038GTA	15.0	20	15.0	20	1	7.5	7.5	6,000
	CW4E048GTA	15.0	20	15.0	20	1	7.5	7.5	6,000
	CW4E077GTA	15.0	20	1.61	20	1	15.1	15.1	12,000
	CW4E097GTA	15.0	20	1.61	20	1	15.1	15.1	12,000
	CW4E115GTA	15.0	20	23.6	25	1	22.6	22.6	18,000
	CW4E145GTA	15.0	20	23.6	25	1	22.6	22.6	18,000
	CW4E182GTA	15.0	20	31.1	35	1	30.1	30.1	24,000

2. Econet Enabled Units are not powered by condensing unit so defrost headers are incorporated into shown MCA/MOPD.

*Econet enabled calculations includes a minimum 1 AMP for control voltages.

12 WAREHOUSE UNIT COOLER

LOW TEMPERATURE ELECTRIC DEFROST // 3-PHASE MOTOR W/ HIGH-STATIC FAN BLADES

Model No.	BTUH Capacity @ -20°F S.T. & +10°F TD ¹		CFM	No. of Fans	208-230V/3	460V/3	
	R404A/ R744 DX (CO ₂)	R407A/ R448A/R449A [^]			Total Fan Motor Amps		
6 FPI	CW6E036*HA	36,400	1,900	7,080	1	6.4	3.2
	CW6E047*HA	47,900	54,600	7,010	1	6.4	3.2
	CW6E059*HA	59,200	67,900	6,875	1	6.4	3.2
	CW6E072*HA	72,500	83,500	14,160	2	12.8	6.4
	CW6E096*HA	96,100	109,400	14,030	2	12.8	6.4
	CW6E120*HA	120,000	137,200	13,750	2	12.8	6.4
	CW6E143*HA	143,600	163,100	21,040	3	19.2	9.6
	CW6E179*HA	179,500	206,600	20,625	3	19.2	9.6
	CW6E216*HA	216,200	246,100	27,500	4	25.6	12.8

Model No.	BTUH Capacity @ -20°F S.T. & +10°F TD ¹		CFM	No. of Fans	208-230V/3	460V/3	
	R404A / R744 DX (CO ₂)	R407A / R448A / R449A [^]			Total Fan Motor Amps		
4 FPI	CW4E038*HA	38,300	43,600	7,010	1	6.4	3.2
	CW4E048*HA	48,900	56,000	6,875	1	6.4	3.2
	CW4E077*HA	77,300	88,600	14,030	2	12.8	6.4
	CW4E097*HA	97,000	111,000	13,750	2	12.8	6.4
	CW4E115*HA	115,600	131,200	21,040	3	19.2	9.6
	CW4E145*HA	145,700	166,400	20,625	3	19.2	9.6
	CW4E182*HA	182,200	206,500	27,500	4	25.6	12.8

*High Static Fan Blades are capable of .35" water column external static pressure for duct or air flow accessories.

*Models with high static fan blades should not be used with the presence of external static pressure.

LOW TEMPERATURE ELECTRIC DEFROST // 3-PHASE MOTOR W/ HIGH-STATIC FAN BLADES

Model No.		208-230V/3							Heater Watts
		Base Model		EcoNet Enabled ²		Heater Amps			
		MCA	MOPD	MCA	MOPD	No. of Circuits	Amps Each Circuit	Total Heater Amps	
6 FPI	CW6E036EHA	15.0	20	16.4	20	1	14.4	14.4	6,000
	CW6E047EHA	15.0	20	16.4	20	1	14.4	14.4	6,000
	CW6E059EHA	15.0	20	16.4	20	1	14.4	14.4	6,000
	CW6E072EHA	15.0	20	30.9	35	1	28.9	28.9	12,000
	CW6E096EHA	15.0	20	30.9	35	1	28.9	28.9	12,000
	CW6E120EHA	15.0	20	30.9	35	1	28.9	28.9	12,000
	CW6E143EHA	20.8	25	45.3	50	1	43.3	43.3	18,000
	CW6E179EHA	20.8	25	45.3	50	1	43.3	43.3	18,000
	CW6E216EHA	27.2	30	59.7	60	2	28.9	57.7	24,000

Model No.		208-230V/3							Heater Watts
		Base Model		EcoNet Enabled ²		Heater Amps			
		MCA	MOPD	MCA	MOPD	No. of Circuits	Amps Each Circuit	Total Heater Amps	
4 FPI	CW4E038EHA	15.0	20	16.4	20	1	14.4	14.4	6,000
	CW4E048EHA	15.0	20	16.4	20	1	14.4	14.4	6,000
	CW4E077EHA	15.0	20	30.9	35	1	28.9	28.9	12,000
	CW4E097EHA	15.0	20	30.9	35	1	28.9	28.9	12,000
	CW4E115EHA	20.8	25	45.3	50	1	43.3	43.3	18,000
	CW4E145EHA	20.8	25	45.3	50	1	43.3	43.3	18,000
	CW4E182EHA	27.2	30	59.7	60	2	28.9	57.7	24,000

2. Econet Enabled Units are not powered by condensing unit so defrost headers are incorporated into shown MCA/MOPD.

*Econet enabled calculations includes a minimum 1 AMP for control voltages.

*High Static Fan Blades are capable of .35" water column external static pressure for duct or air flow accessories.

*Models with high static fan blades should not be used with the presence of external static pressure.

14 WAREHOUSE UNIT COOLER

LOW TEMP ELECTRIC DEFROST // 3-PHASE MOTOR W/ HIGH-STATIC FAN BLADES

Model No.		460V/3							Heater Watts
		Base Model		EcoNet Enabled ²		Heater Amps			
		MCA	MOPD	MCA	MOPD	No. of Circuits	Amps Each Circuit	Total Heater Amps	
6 FPI	CW6E036GHA	15.0	20	15.0	20	1	7.5	7.5	6,000
	CW6E047GHA	15.0	20	15.0	20	1	7.5	7.5	6,000
	CW6E059GHA	15.0	20	15.0	20	1	7.5	7.5	6,000
	CW6E072GHA	15.0	20	16.1	20	1	15.1	15.1	12,000
	CW6E096GHA	15.0	20	16.1	20	1	15.1	15.1	12,000
	CW6E120GHA	15.0	20	16.1	20	1	15.1	15.1	12,000
	CW6E143GHA	15.0	20	23.6	25	1	22.6	22.6	18,000
	CW6E179GHA	15.0	20	23.6	25	1	22.6	22.6	18,000
	CW6E216GHA	15.0	20	31.1	35	2	30.1	30.1	24,000

Model No.		460V/3							Heater Watts
		Base Model		EcoNet Enabled ²		Heater Amps			
		MCA	MOPD	MCA	MOPD	No. of Circuits	Amps Each Circuit	Total Heater Amps	
4 FPI	CW4E038GHA	15.0	20	15.0	20	1	7.5	7.5	6,000
	CW4E048GHA	15.0	20	15.0	20	1	7.5	7.5	6,000
	CW4E077GHA	15.0	20	16.1	20	1	15.1	15.1	12,000
	CW4E097GHA	15.0	20	16.1	20	1	15.1	15.1	12,000
	CW4E115GHA	15.0	20	23.6	25	1	22.6	22.6	18,000
	CW4E145GHA	15.0	20	23.6	25	1	22.6	22.6	18,000
		CW4E182GHA	15.0	20	31.1	35	1	30.1	30.1

2. Econet Enabled Units are not powered by condensing unit so defrost headers are incorporated into shown MCA/MOPD.

*Econet enabled calculations include a minimum 1 AMP for control voltages.

*High Static Fan Blades are capable of .35" water column external static pressure for duct or air flow accessories.

*Models with high static fan blades should not be used with the presence of external static pressure.

PERFORMANCE AND ELECTRICAL DATA // HOT GAS 3-PIPE DEFROST: 3-PHASE MOTOR

Model No.	BTUH Capacity @ -20°F S.T. & 10°F TD ¹		CFM	No. of Fans	208-230V/3	460V/3	208-230V/3	460V/3	
	R404A	R407A/R448A/ R449A [^]			Total Fan Motor Amps	MCA	MOPD		
6 FPI - RW*H, RW*K	CW6*036*TA	36,400	41,900	7,080	1	4.1	2.0	15.0	20
	CW6*047*TA	47,900	54,600	7,010	1	4.1	2.0	15.0	20
	CW6*059*TA	59,200	67,900	6,875	1	4.1	2.0	15.0	20
	CW6*072*TA	72,500	83,500	14,160	2	8.2	4.0	15.0	20
	CW6*096*TA	96,100	109,400	14,030	2	8.2	4.0	15.0	20
	CW6*120*TA	120,000	137,200	13,750	2	8.2	4.0	15.0	20
	CW6*143*TA	143,600	163,100	21,040	3	12.3	6.0	15.0	20
	CW6*179*TA	179,500	206,600	20,625	3	12.3	6.0	15.0	20
4 FPI - RW*H, RW*K	CW4*038*TA	38,300	43,600	7,010	1	4.1	2.0	15.0	20
	CW4*048*TA	48,900	56,000	6,875	1	4.1	2.0	15.0	20
	CW4*077*TA	77,300	88,600	14,030	2	8.2	4.0	15.0	20
	CW4*097*TA	97,000	111,000	13,750	2	8.2	4.0	15.0	20
	CW4*115*TA	115,600	131,200	21,040	3	12.3	6.0	15.0	20
	CW4*145*TA	145,700	166,400	20,625	3	12.3	6.0	15.0	20
	CW4*182*TA	182,200	206,500	27,500	4	16.4	8.0	17.4	20

Model No.	Electric Drain Pan Heater Amps		Heater Watts	
	208-230V/1	460V/1		
6 FPI - RW*H	CW6H036*TA	8.3	4.3	2,000
	CW6H047*TA	8.3	4.3	2,000
	CW6H059*TA	8.3	4.3	2,000
	CW6H072*TA	16.7	8.7	4,000
	CW6H096*TA	16.7	8.7	4,000
	CW6H120*TA	16.7	8.7	4,000
	CW6H143*TA	25.0	13.0	6,000
	CW6H179*TA	25.0	13.0	6,000
4 FPI - RW*H	CW4H038*TA	8.3	4.3	2,000
	CW4H048*TA	8.3	4.3	2,000
	CW4H077*TA	16.7	8.7	4,000
	CW4H097*TA	16.7	8.7	4,000
	CW4H115*TA	25.0	13.0	6,000
	CW4H145*TA	25.0	13.0	6,000
	CW4H182*TA	33.3	17.4	8,000

Each asterisk represents a variable character based on defrost and voltage ordered. Hot Gas 3-Pipe Version (H - Hot Gas Defrost 3-Pipe with Electric Drain Pan Heater, K - Hot Gas Defrost 3-Pipe with Hot Gas Drain Pan). [^]R407A, R448A and R449A are rated at dew point temperature. Use R407A capacity ratings for R407C and R407F. See page 4 for nomenclature. *High Static Fan Blades are capable of .35" water column external static pressure for duct or air flow accessories. *Models with high static fan blades should not be used with the presence of external static pressure.

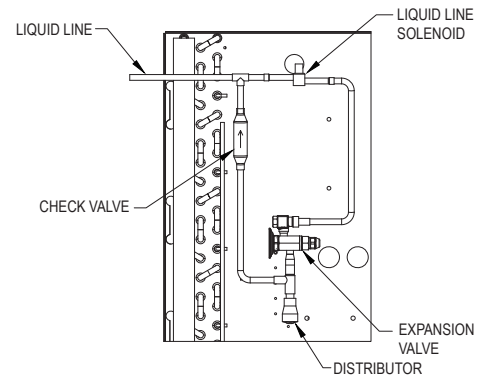

Capacity Correction for Low Temp Electric and Hot Gas Defrost

SST (Dew)	0°F	-10°F	-20°F	-30°F	-40°F
Multiply Capacity by:	1.075	1.0375	1	0.9625	0.925

16 WAREHOUSE UNIT COOLER

PERFORMANCE AND ELECTRICAL DATA // HOT GAS 3-PIPE DEFROST: 3-PHASE MOTOR W/ HIGH-STATIC FAN BLADES

Model No.	BTUH Capacity @ -20°F S.T. & +10°F TD ¹		CFM	No. of Fans	208-230V/3	460V/3	208-230V/3	460V/3	
	R404A	R407A/ R448A/ R449A [^]			Total Fan Motor Amps		MCA	MOPD	
6 FPI - RW*H, RW*K	CW6*036*HA	36,400	41,900	7,080	1	6.4	3.2	15.0	20
	CW6*047*HA	47,900	54,600	7,010	1	6.4	3.2	15.0	20
	CW6*059*HA	59,200	67,900	6,875	1	6.4	3.2	15.0	20
	CW6*072*HA	72,500	83,500	14,160	2	12.8	6.4	15.0	20
	CW6*096*HA	96,100	109,400	14,030	2	12.8	6.4	15.0	20
	CW6*120*HA	120,000	137,200	13,750	2	12.8	6.4	15.0	20
	CW6*143*HA	143,600	163,100	21,040	3	19.2	9.6	20.8	25
	CW6*179*HA	179,500	206,600	20,625	3	19.2	9.6	20.8	25
CW6*216*HA	216,200	246,100	27,500	4	25.6	12.8	27.2	30	
4 FPI - RW*H, RW*K	CW4*038*HA	38,300	43,600	7,010	1	6.4	3.2	15.0	20
	CW4*048*HA	48,900	56,000	6,875	1	6.4	3.2	15.0	20
	CW4*077*HA	77,300	88,600	14,030	2	12.8	6.4	15.0	20
	CW4*097*HA	97,000	111,000	13,750	2	12.8	6.4	15.0	20
	CW4*115*HA	115,600	131,200	21,040	3	19.2	9.6	20.8	25
	CW4*145*HA	145,700	166,400	20,625	3	19.2	9.6	20.8	25
	CW4*182*HA	182,200	206,500	27,500	4	25.6	12.8	27.2	30

Model No.	Electric Drain Pan Heater Amps		Heater Watts	
	208-230V/1	460V/1		
6 FPI - RW*H	CW6*036*HA	8.3	4.3	2,000
	CW6*047*HA	8.3	4.3	2,000
	CW6*059*HA	8.3	4.3	2,000
	CW6*072*HA	16.7	8.7	4,000
	CW6*096*HA	16.7	8.7	4,000
	CW6*120*HA	16.7	8.7	4,000
	CW6*143*HA	25.0	13.0	6,000
	CW6*179*HA	25.0	13.0	6,000
CW6*216*HA	33.3	17.4	8,000	
4 FPI - RW*H	CW4*038*HA	8.3	4.3	2,000
	CW4*048*HA	8.3	4.3	2,000
	CW4*077*HA	16.7	8.7	4,000
	CW4*097*HA	16.7	8.7	4,000
	CW4*115*HA	25.0	13.0	6,000
	CW4*145*HA	25.0	13.0	6,000
	CW4*182*HA	33.3	17.4	8,000

Each asterisk represents a variable character based on defrost and voltage ordered. Hot Gas 3-Pipe Version (H - Hot Gas Defrost 3-Pipe with Electric Drain Pan Heater, K - Hot Gas Defrost 3-Pipe with Hot Gas Drain Pan). [^]R407A, R448A and R449A are rated at dew point temperature. Use R407A capacity ratings for R407C and R407F. See page 4 for nomenclature. *High Static Fan Blades are capable of .35" water column external static pressure for duct or air flow accessories. *Models with high static fan blades should not be used with the presence of external static pressure.

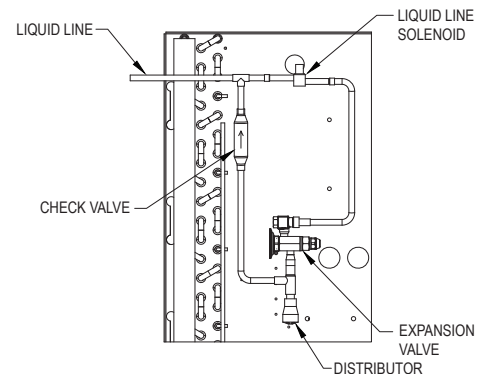

Capacity Correction for Low Temp Electric and Hot Gas Defrost

SST (Dew)	0°F	-10°F	-20°F	-30°F	-40°F
Multiply Capacity by:	1.075	1.0375	1	0.9625	0.925

PERFORMANCE AND ELECTRICAL DATA // HOT GAS REVERSE CYCLE DEFROST: 3-PHASE MOTOR

Model No.		BTUH Capacity @ -20°F S.T. & 10°F TD ¹		CFM	No. of Fans	208-230V/3	460V/3	208-230V/3	460V/3
		R404A	R407A/R448A/ R449A [^]			Total Fan Motor Amps		MCA	MOPD
6 FPI - RW*G, RW*L	CW6*036*TA	36,400	41,900	7,080	1	4.1	2.0	15.0	20
	CW6*047*TA	47,900	54,600	7,010	1	4.1	2.0	15.0	20
	CW6*059*TA	59,200	67,900	6,875	1	4.1	2.0	15.0	20
	CW6*072*TA	72,500	83,500	14,160	2	8.2	4.0	15.0	20
	CW6*096*TA	96,100	109,400	14,030	2	8.2	4.0	15.0	20
	CW6*120*TA	120,000	137,200	13,750	2	8.2	4.0	15.0	20
	CW6*143*TA	143,600	163,100	21,040	3	12.3	6.0	15.0	25
	CW6*179*TA	179,500	206,600	20,625	3	12.3	6.0	15.0	25
	CW6*216*TA	216,200	246,100	27,500	4	16.4	8.0	17.4	30
4 FPI - RW*G, RW*L	CW4*038*TA	38,300	43,600	7,010	1	4.1	2.0	15.0	20
	CW4*048*TA	48,900	56,000	6,875	1	4.1	2.0	15.0	20
	CW4*077*TA	77,300	88,600	14,030	2	8.2	4.0	15.0	25
	CW4*097*TA	97,000	111,000	13,750	2	8.2	4.0	15.0	25
	CW4*115*TA	115,600	131,200	21,040	3	12.3	6.0	15.0	25
	CW4*145*TA	145,700	166,400	20,625	3	12.3	6.0	15.0	25
	CW4*182*TA	182,200	206,500	27,500	4	16.4	8.0	17.4	30

Model No.		208-230V/1	460V/1	Heater Watts
		Electric Drain Pan Heater Amps		
6 FPI - RW*G	CW6G036*TA	8.3	4.3	2,000
	CW6G047*TA	8.3	4.3	2,000
	CW6G059*TA	8.3	4.3	2,000
	CW6G072*TA	16.7	8.7	4,000
	CW6G096*TA	16.7	8.7	4,000
	CW6G120*TA	16.7	8.7	4,000
	CW6G143*TA	25.0	13.0	6,000
	CW6G179*TA	25.0	13.0	6,000
	CW6G216*TA	33.3	17.4	8,000
4 FPI - RW*G	CW4G038*TA	8.3	4.3	2,000
	CW4G048*TA	8.3	4.3	2,000
	CW4G077*TA	16.7	8.7	4,000
	CW4G097*TA	16.7	8.7	4,000
	CW4G115*TA	25.0	13.0	6,000
	CW4G145*TA	25.0	13.0	6,000
	CW4G182*TA	33.3	17.4	8,000

Each asterisk represents a variable character based on defrost and voltage ordered. Reverse Cycle (2-Pipe) Version (G: Hot Gas Defrost Reverse Cycle with Electric Drain Pan Heater, L: Hot Gas Defrost Reverse Cycle with Hot Gas Drain Pan). See page 4 for nomenclature. ^ R407A, R448A and R449A are rated at dew point temperature. Use R407A capacity ratings for R407C and R407F.

Capacity Correction for Low Temp Electric and Hot Gas Defrost

SST (Dew)	0°F	-10°F	-20°F	-30°F	-40°F
Multiply Capacity by:	1.075	1.0375	1	0.9625	0.925

18 WAREHOUSE UNIT COOLER

PERFORMANCE AND ELECTRICAL DATA // HOT GAS REVERSE CYCLE DEFROST: 3-PHASE MOTOR W/ HIGH-STATIC FAN BLADES

Model No.	BTUH Capacity @ -20°F S.T. & +10°F TD ¹		CFM	No. of Fans	208-230V/3	460V/3	208-230V/3		460V/3		
	R404A	R407A/ R448A/ R449A [^]			Total Fan Motor AMPS		MCA	MOPD	MCA	MOPD	
6 FPI - RW*G, RW*L	CW6*036*HA	36,400	41,900	7,080	1	6.4	3.2	15.0	20	15.0	20
	CW6*047*HA	47,900	54,600	7,010	1	6.4	3.2	15.0	20	15.0	20
	CW6*059*HA	59,200	67,900	6,875	1	6.4	3.2	15.0	20	15.0	20
	CW6*072*HA	72,500	83,500	14,160	2	12.8	6.4	15.0	20	15.0	20
	CW6*096*HA	96,100	109,400	14,030	2	12.8	6.4	15.0	20	15.0	20
	CW6*120*HA	120,000	137,200	13,750	2	12.8	6.4	15.0	20	15.0	20
	CW6*143*HA	143,600	163,100	21,040	3	19.2	9.6	20.8	25	15.0	20
	CW6*179*HA	179,500	206,600	20,625	3	19.2	9.6	20.8	25	15.0	20
CW6*216*HA	216,200	246,100	27,500	4	25.6	12.8	27.2	30	15.0	20	
4 FPI - RW*G, RW*L	CW4*038*HA	38,300	43,600	7,010	1	6.4	3.2	15.0	20	15.0	20
	CW4*048*HA	48,900	56,000	6,875	1	6.4	3.2	15.0	20	15.0	20
	CW4*077*HA	77,300	88,600	14,030	2	12.8	6.4	15.0	25	15.0	20
	CW4*097*HA	97,000	111,000	13,750	2	12.8	6.4	15.0	25	15.0	20
	CW4*115*HA	115,600	131,200	21,040	3	19.2	9.6	20.8	25	15.0	20
	CW4*145*HA	145,700	166,400	20,625	3	19.2	9.6	20.8	25	15.0	20
	CW4*182*HA	182,200	206,500	27,500	4	25.6	12.8	2.72	30	15.0	20

Model No.	208-230V/1	460V/1	Heater Watts	
	Electric Drain Pan Heater Amps			
6 FPI - RW*H	CW6G036*HA	8.3	4.3	2,000
	CW6G047*HA	8.3	4.3	2,000
	CW6G059*HA	8.3	4.3	2,000
	CW6G072*HA	16.7	8.7	4,000
	CW6G096*HA	16.7	8.7	4,000
	CW6G120*HA	16.7	8.7	4,000
	CW6G143*HA	25.0	13.0	6,000
	CW6G179*HA	25.0	13.0	6,000
CW6G216*HA	33.3	17.4	8,000	
4 FPI - RW*H	CW4G038*HA	8.3	4.3	2,000
	CW4G048*HA	8.3	4.3	2,000
	CW4G077*HA	16.7	8.7	4,000
	CW4G097*HA	16.7	8.7	4,000
	CW4G115*HA	25.0	13.0	6,000
	CW4G145*HA	25.0	13.0	6,000
CW4G182*HA	33.3	17.4	8,000	

Each asterisk represents a variable character based on defrost and voltage ordered. Hot Gas 3-Pipe Version (H - Hot Gas Defrost 3-Pipe with Electric Drain Pan Heater, K - Hot Gas Defrost 3-Pipe with Hot Gas Drain Pan). [^] R407A, R448A and R449A are rated at dew point temperature. Use R407A capacity ratings for R407C and R407F. High static models are capable of .35" water column external static pressure for duct or air flow accessories. Models with high static fan blades should not be used without the presence of external static pressure. See page 4 for nomenclature.

Capacity Correction for Low Temp Electric and Hot Gas Defrost

SST (Dew)	0°F	-10°F	-20°F	-30°F	-40°F
Multiply Capacity by:	1.075	1.0375	1	0.9625	0.925

Each asterisk represents a variable character based on defrost and voltage ordered. Reverse Cycle (2-Pipe) Version (G: Hot Gas Defrost Reverse Cycle with Electric Drain Pan Heater, L: Hot Gas Defrost Reverse Cycle with Hot Gas Drain Pan). See page 4 for nomenclature.

DISTRIBUTOR NOZZLE AND EXPANSION VALVES // AIR DEFROST

Model No.		Part Numbers						No. of Circuits
		Nozzle @ Liq. Temp.		TXV [^] @ Liq. Temp.		EEV @ Liq. Temp.		
		50°F	100°F	50°F	100°F	50°F	100°F	
6 FPI -R404A	CW6A034*TA	G#1-1/2	G#4	SBFSE-B-C	SBFSE-C-C	SER-C	SER-C	6
	CW6A047*TA	G#1-1/2	G#5	SBFSE-C-C	OSE-6-C	SER-C	SER-C	6
	CW6A058*TA	E#2	E#6	OSE-6-C	OSE-6-C	SER-C	SER-D	12
	CW6A069*TA	E#2-1/2	E#10	OSE-6-C	OSE-6-C	SER-C	SER-D	9
	CW6A094*TA	C#3	C#12	OSE-6-C	OSE-9-C	SER-D	SER-D	18
	CW6A117*TA	C#4	C#15	OSE-9-C	OSE-9-C	SER-D	SERI-F	18
	CW6A143*TA	C#5	C#20	OSE-9-C	OSE-12-C	SER-D	SERI-F	18
	CW6A176*TA	C#6	C#25	OSE-12-C	OSE-21-C	SERI-F	SERI-G	24
	CW6A190*TA	A#8	A#25	OSE-12-C	OSE-21-C	SERI-F	SERI-G	27
	CW6A234*TA	A#10	A#30	OSE-12-C	OSE-21-C	SERI-F	SERI-G	36
6 FPI - R407A/R448A/R449A†	CW6A034*TA	G#1-1/2	G#4	SBFDE-B-C	SBFDE-C-C	SER-B	SER-C	6
	CW6A047*TA	G#1-1/2	G#5	SBFDE-C-C	SBFDE-C-C	SER-C	SER-C	6
	CW6A058*TA	E#2	E#6	SBFDE-C-C	EBSDE-7-C	SER-C	SER-C	12
	CW6A069*TA	E#2-1/2	E#8	SBFDE-C-C	EBSDE-7-C	SER-C	SER-D	9
	CW6A094*TA	C#4	C#12	EBSDE-7-C	EBSDE-10-C	SER-D	SER-D	18
	CW6A117*TA	C#4	C#15	EBSDE-7-C	ODE-12-C	SER-D	SERI-F	18
	CW6A143*TA	C#5	C#17	EBSDE-10-C	ODE-12-C	SER-D	SERI-F	18
	CW6A176*TA	C#6	C#20	EBSDE-12-C	ODE-17-C	SERI-F	SERI-F	24
	CW6A190*TA	A#8	A#25	EBSDE-12-C	ODE-17-C	SERI-F	SERI-G	27
	CW6A234*TA	A#10	A#30	EBSDE-17-C	ODE-28-C	SERI-F	SERI-G	36

The distributor lines are 1/4" tube & 31" long.

* Each asterisk represents a variable character based on voltage ordered. See page 4 for nomenclature.

[^] TXV selections are based on +25°F suction temp., 8°F to 12°F evaporator TD. Contact factory for operating conditions outside of this range.

† SBFDE ODE, and EBSDE expansion valves are compatible with expansion valves are compatible with R407A, R448A and R449A/B.

For other valves, follow manufacturers selection guidelines.

Base models (no factory-mounted components) include nozzles sized for 100°F liquid shipped loose.

20 WAREHOUSE UNIT COOLER

DISTRIBUTOR NOZZLE AND EXPANSION VALVES // MEDIUM TEMPERATURE ELECTRIC DEFROST

Model No.		Nozzle @ Liquid Temp		TXV @ Liquid Temp		EEV @ Liquid Temp		No. of Circuits
		50°F	100°F	50°F	100°F	50°F	100°F	
6 FPI - R404A	CW6D033*TA	G#1-1/2	G#4	SBFSE-B-C	SBFSE-C-C	SER-C	SER-C	6
	CW6D046*TA	G#1-1/2	G#5	SBFSE-B-C	OSE-6-C	SER-C	SER-C	6
	CW6D057*TA	E#2	E#6	OSE-6-C	OSE-6-C	SER-C	SER-D	12
	CW6D068*TA	E#2-1/2	E#10	OSE-6-C	OSE-6-C	SER-C	SER-D	9
	CW6D093*TA	C#3	C#12	OSE-6-C	OSE-9-C	SER-D	SER-D	18
	CW6D116*TA	C#4	C#15	OSE-9-C	OSE-9-C	SER-D	SERI-F	18
	CW6D142*TA	C#5	C#20	OSE-9-C	OSE-12-C	SER-D	SERI-F	18
	CW6D175*TA	C#6	C#25	OSE-12-C	OSE-21-C	SERI-F	SERI-G	24
	CW6D189*TA	A#8	A#25	OSE-12-C	OSE-21-C	SERI-F	SERI-G	27
CW6D233*TA	A#10	A#30	OSE-12-C	OSE-21-C	SERI-F	SERI-G	36	
4 FPI - R404A	CW4D029*TA	G#1-1/2	G#4	SBFSE-B-C	SBFSE-C-C	SER-C	SER-C	6
	CW4D041*TA	G#1-1/2	G#5	SBFSE-B-C	OSE-6-C	SER-C	SER-C	6
	CW4D050*TA	E#2	E#6	OSE-6-C	OSE-6-C	SER-C	SER-D	12
	CW4D060*TA	E#2-1/2	E#10	OSE-6-C	OSE-6-C	SER-C	SER-D	9
	CW4D082*TA	C#3	C#12	OSE-6-C	OSE-9-C	SER-D	SER-D	18
	CW4D103*TA	C#4	C#15	OSE-9-C	OSE-9-C	SER-D	SERI-F	18
	CW4D126*TA	C#5	C#20	OSE-9-C	OSE-12-C	SER-D	SERI-F	18
	CW4D155*TA	C#6	C#25	OSE-12-C	OSE-21-C	SERI-F	SERI-G	24
	CW4D167*TA	A#8	A#25	OSE-12-C	OSE-21-C	SERI-F	SERI-G	27
CW4D206*TA	A#10	A#30	OSE-12-C	OSE-21-C	SERI-F	SERI-G	36	
6 FPI - R407A/R407C/R448A/R449A	CW6D033*TA	G#1-1/2	G#4	SBFDE-B-C	SBFDE-C-C	SER-C	SER-C	6
	CW6D046*TA	G#1-1/2	G#5	SBFDE-C-C	SBFDE-C-C	SER-C	SER-C	6
	CW6D057*TA	E#2	E#6	SBFDE-C-C	EBSDE-7-C	SER-C	SER-C	12
	CW6D068*TA	E#2-1/2	E#8	SBFDE-C-C	EBSDE-7-C	SER-C	SER-D	9
	CW6D093*TA	C#4	C#12	EBSDE-7-C	EBSDE-10-C	SER-D	SER-D	18
	CW6D116*TA	C#4	C#15	EBSDE-7-C	ODE-12-C	SER-D	SERI-F	18
	CW6D142*TA	C#5	C#17	EBSDE-10-C	ODE-12-C	SER-D	SERI-F	18
	CW6D175*TA	C#6	C#25	EBSDE-12-C	ODE-17-C	SERI-F	SERI-F	24
	CW6D189*TA	A#8	A#25	EBSDE-12-C	ODE-17-C	SERI-F	SERI-G	27
	CW6D233*TA	A#10	A#30	EBSE-17-C	ODE-28-C	SERI-F	SERI-G	36

The distributor lines are 1/4" tube & 31" long.

* Each asterisk represents a variable character based on voltage ordered. See page 4 for nomenclature.

^ TXV selections are based on +25°F suction temp., 8°F to 12°F evaporator TD. Contact factory for operating conditions outside of this range.

† SBFDE ODE, and EBSDE expansion valves are compatible with expansion valves are compatible with R407A, R448A and R449A/B. For other valves, follow manufacturers selection guidelines. Base models (no factory-mounted components) include nozzles sized for 100°F liquid shipped loose.

DISTRIBUTOR NOZZLE AND EXPANSION VALVES // LOW TEMPERATURE ELECTRIC DEFROST

Model No.		Part Numbers						No. of Circuits
		Nozzle @ Liq. Temp.		TXV [^] @ Liq. Temp.		EEV @ Liq. Temp.		
		50°F	100°F	50°F	100°F	50°F	100°F	
6 FPI - R404A	CW6E036**A	E#3	E#8	SBFSE-C-Z	EBSSE-6-Z	SER-C	SER-C	9
	CW6E047**A	E#4	E#10	OSE-6-Z	EBSSE-7-1/2-Z	SER-C	SER-C	9
	CW6E059**A	E#5	E#12	OSE-6-Z	EBSSE-10-Z	SER-C	SER-D	12
	CW6E072**A	C#6	C#17	OSE-6-Z	EBSSE-10-Z	SER-C	SER-D	18
	CW6E096**A	C#10	C#20	OSE-9-Z	EBSSE-13-Z	SER-D	SER-D	18
	CW6E120**A	C#12	C#25	OSE-12-Z	OSE-21-C	SER-D	SERI-F	24
	CW6E143**A	A#15	A#35	OSE-12-Z	OSE-30-C	SER-D	SERI-F	27
	CW6E179**A	A#17	A#40	OSE-21-Z	OSE-30-C	SERI-F	SERI-G	36
CW6E216**A	A#20	A#50	OSE-35-Z	OSE-45-C	SERI-F	SERI-G	36	
4 FPI - R404A	CW4E038**A	E#3	E#8	SBFSE-C-Z	OSE-6-Z	SER-C	SER-C	9
	CW4E048**A	E#4	E#12	OSE-6-Z	OSE-6-Z	SER-C	SER-C	12
	CW4E077**A	C#8	C#17	OSE-9-Z	OSE-12-Z	SER-C	SER-D	18
	CW4E097**A	C#10	C#20	OSE-9-Z	OSE-12-Z	SER-D	SER-D	24
	CW4E115**A	A#12	A#30	OSE-12-Z	OSE-21-Z	SER-D	SERI-F	27
	CW4E145**A	A#15	A#35	OSE-12-Z	OSE-30-Z	SER-D	SERI-F	36
	CW4E182**A	A#20	A#40	OSE-21-Z	OSE-30-Z	SERI-F	SERI-G	36
6 FPI - R407A/R448A/R449A†	CW6E036**A	E#2-1/2	E#6	SBFDE-C-Z	ODE-7-Z	SER-B	SER-C	9
	CW6E047**A	E#4	E#8	EBSDE-7-Z	ODE-12-Z	SER-C	SER-C	9
	CW6E059**A	E#5	E#12	EBSDE-7-Z	ODE-12-Z	SER-C	SER-D	12
	CW6E096**A	C#6	C#115	EBSDE-10-Z	ODE-12-Z	SER-C	SER-D	18
	CW6E096**A	C#10	C#17	ODE-12-Z	ODE-17-Z	SER-D	SER-D	18
	CW6E120**A	C#12	C#25	ODE-17-Z	ODE-28-Z	SER-D	SER-D	24
	CW6E143**A	A#15	A#30	ODE-17-Z	ODE-28-Z	SER-D	SERI-F	27
	CW6E179**A	A#17	A#35	ODE-28-Z	ODE-40-Z	SERI-F	SERI-G	36
CW6E216**A	A#20	A#40	ODE-28-Z	ODE-45-Z	SERI-F	SERI-G	36	
4 FPI - R407A/R448A/R449A†	CW4E038**A	E#3	E#6	SBFDE-C-Z	ODE-7-Z	SER-C	SER-C	9
	CW4E048**A	E#4	E#8	SBFDE-C-Z	ODE-7-Z	SER-C	SER-C	12
	CW4E077**A	C#6	C#15	ODE-12-Z	ODE-12-Z	SER-C	SER-D	18
	CW4E097**A	C#8	C#17	ODE-12-Z	ODE-17-Z	SER-D	SER-D	24
	CW4E115**A	A#12	A#20	ODE-17-Z	ODE-28-Z	SER-D	SER-D	27
	CW4E145**A	A#15	A#30	ODE-17-Z	ODE-28-Z	SER-D	SERI-F	36
	CW4E182**A	A#17	A#35	ODE-28-Z	ODE-40-Z	SERI-F	SERI-G	36

The distributor lines are 1/4" tube & 31" long.

* Each asterisk represents a variable character based on voltage ordered. See page 4 for nomenclature.

[^] TXV selections are based on -20°F suction temp., 8°F to 12°F evaporator TD. Contact factory for operating conditions outside of this range.

† SBFDE, ODE, and EBSDE expansion valves are compatible with expansion valves compatible with R407A, R448A and R449A/B. For other valves, follow manufacturers selection guidelines. Base models (no factory-mounted components) include nozzles sized for 100°F liquid shipped loose.

22 WAREHOUSE UNIT COOLER

DISTRIBUTOR NOZZLE AND EXPANSION VALVES // HOT GAS DEFROST

Model No.		Part Numbers						No. of Circuits
		Nozzle @ Liq. Temp.		TXV [^] @ Liq. Temp.		EEV @ Liq. Temp.		
		50°F	100°F	50°F	100°F	50°F	100°F	
6 FPI - RW*H, RW*G, RW*K, RW*L	CW6*036**A	E#3	E#8	SBFSE-C-Z	EBSSE-6-Z	SER-C	SER-C	9
	CW6*047**A	E#4	E#10	OSE-6-Z	EBSSE-7-1/2-Z	SER-C	SER-C	9
	CW6*059**A	E#5	E#12	OSE-6-Z	EBSSE-10-Z	SER-C	SER-D	12
	CW6*072**A	C#6	C#17	OSE-6-Z	EBSSE-10-Z	SER-C	SER-D	18
	CW6*096**A	C#10	C#20	OSE-9-Z	EBSSE-13-Z	SER-D	SER-D	18
	CW6*120**A	C#12	C#25	OSE-12-Z	OSE-21-C	SER-D	SERI-F	24
	CW6*143**A	A#15	A#35	OSE-12-Z	OSE-30-C	SER-D	SERI-F	27
	CW6*179**A	A#17	A#40	OSE-21-Z	OSE-30-C	SERI-F	SERI-G	36
CW6*216**A	A#20	A#50	OSE-35-Z	OSE-45-C	SERI-F	SERI-G	36	
4 FPI - RW*H, RW*G, RW*K, RW*L	CW4*038**A	E#3	E#8	SBFSE-C-Z	OSE-6-Z	SER-C	SER-C	9
	CW4*048**A	E#4	E#12	OSE-6-Z	OSE-6-Z	SER-C	SER-C	12
	CW4*077**A	C#8	C#17	OSE-9-Z	OSE-12-Z	SER-C	SER-D	18
	CW4*097**A	C#10	C#20	OSE-9-Z	OSE-12-Z	SER-D	SER-D	24
	CW4*115**A	A#12	A#30	OSE-12-Z	OSE-21-Z	SER-D	SERI-F	27
	CW4*145**A	A#15	A#35	OSE-12-Z	OSE-30-Z	SER-D	SERI-F	36
	CW4*182**A	A#20	A#40	OSE-21-Z	OSE-30-Z	SERI-F	SERI-G	36
6 FPI - R407A/R448A/R449A†	CW6*036**A	E#2-1/2	E#6	SBFDE-C-Z	ODE-7-Z	SER-B	SER-C	9
	CW6*047**A	E#4	E#8	EBSDE-7-Z	ODE-12-Z	SER-C	SER-C	9
	CW6*059**A	E#5	E#12	EBSDE-7-Z	ODE-12-Z	SER-C	SER-C	12
	CW6*072**A	C#6	C#15	EBSDE-10-Z	ODE-12-Z	SER-C	SER-D	18
	CW6*096**A	C#8	C#17	ODE-12-Z	ODE-17-Z	SER-D	SER-D	18
	CW6*120**A	C#12	C#25	ODE-17-Z	ODE-28-Z	SER-D	SER-D	24
	CW6*143**A	A#15	A#30	ODE-17-Z	ODE-28-Z	SER-D	SERI-F	27
	CW6*179**A	A#17	A#35	ODE-28-Z	ODE-40-Z	SERI-F	SERI-G	36
CW6*216**A	A#20	A#40	ODE-28-Z	ODE-45-Z	SERI-F	SERI-G	36	
4 FPI - R407A/R448A/R449A†	CW4*038**A	E#3	E#6	SBFDE-C-Z	ODE-7-Z	SER-C	SER-C	9
	CW4*048**A	E#4	E#8	SBFDE-C-Z	ODE-7-Z	SER-C	SER-C	12
	CW4*077**A	C#6	C#15	ODE-12-Z	ODE-12-Z	SER-C	SER-D	18
	CW4*097**A	C#8	C#17	ODE-12-Z	ODE-17-Z	SER-D	SER-D	24
	CW4*115**A	A#12	A#20	ODE-17-Z	ODE-28-Z	SER-D	SER-D	27
	CW4*145**A	A#15	A#30	ODE-17-Z	ODE-28-Z	SER-D	SERI-F	36
	CW4*182**A	A#17	A#35	ODE-28-Z	ODE-40-Z	SERI-F	SERI-G	36

The distributor lines are 1/4" tube & 31" long.

For other valves, follow manufacturers selection guidelines.

* Each asterisk represents a variable character based on voltage ordered. See page 4 for nomenclature.

[^] TXV selections are based on -20°F suction temp., 8°F to 12°F evaporator TD. Contact factory for operating conditions outside of this range.

† SBFDE ODE, and EBSDE expansion valves are compatible with expansion valves are compatible with R407A, R448A and R449A/B.

SPECIFICATIONS // AIR DEFROST MODELS: 3-PHASE MOTOR

Model No.	Fan Diam. (In.)	Motor Data			Refrigerant Connections		No. of Hanger Slot Locations	Fig.	Unit Dimensions (In.)			Approx. Unit Wt. (Lbs.)	
		Motor Qty.	HP	RPM	Liquid Line [^]	Suction			L	W	H		
6 FPI	CW6A034*TA	30	1	1	850	1/2	1-1/8	4	1	59-7/8	27-3/8	49-1/4	303
	CW6A047*TA	30	1	1	850	1/2	1-3/8	4	1	59-7/8	27-3/8	49-1/4	303
	CW6A058*TA	30	1	1	850	5/8	1-5/8	4	1	59-7/8	27-3/8	49-1/4	303
	CW6A069*TA	30	2	1	850	5/8	1-5/8	6	2	99-7/8	27-3/8	49-1/4	509
	CW6A094*TA	30	2	1	850	7/8	2-1/8	6	2	99-7/8	27-3/8	49-1/4	509
	CW6A117*TA	30	2	1	850	7/8	2-1/8	6	2	99-7/8	27-3/8	49-1/4	509
	CW6A143*TA	30	3	1	850	7/8	2-1/8	8	3	139-7/8	27-3/8	49-1/4	682
	CW6A176*TA	30	3	1	850	1-1/8	2-1/8	8	3	139-7/8	27-3/8	49-1/4	682
	CW6A190*TA	30	4	1	850	1-1/8	2-1/8	10	4	179-9/16	27-3/8	49-1/4	1,050
	CW6A234*TA	30	4	1	850	1-1/8	2-1/8	10	4	179-9/16	27-3/8	49-1/4	1,050

* Each asterisk represents a variable character based on voltage ordered. See page 4 for nomenclature.

[^] For units with mounted TXV components. See Nozzle/TXV table for distributor connection size when TXV is field installed.

1. For dimensional distance between hanger slots, consult model's corresponding dimension drawing. Hanger slots are 1" deep x 1/2" wide.

2. Drain is 1-1/4" NPT for all models.

24 WAREHOUSE UNIT COOLER

SPECIFICATIONS // MEDIUM TEMPERATURE ELECTRIC DEFROST

Model No.	Fan Diam. (In.)	Motor Data			Refrigerant Connections		No. of Hanger Slot Loc.	Figure	Unit Dimensions (In.)			Approx. Unit Wt. (Lbs.)	
		Motor Qty.	HP	RPM	Liquid Line [^]	Suction			L	W	H		
6 FPI	CW6D033*TA	30	1	1	850	1/2	1-1/8	4	1	59-7/8	27-3/8	49-1/4	303
	CW6D046*TA	30	1	1	850	1/2	1-3/8	4	1	59-7/8	27-3/8	49-1/4	303
	CW6D057*TA	30	1	1	850	5/8	1-5/8	4	1	59-7/8	27-3/8	49-1/4	303
	CW6D068*TA	30	2	1	850	5/8	1-5/8	6	2	99-7/8	27-3/8	49-1/4	509
	CW6D093*TA	30	2	1	850	7/8	2-1/8	6	2	99-7/8	27-3/8	49-1/4	509
	CW6D116*TA	30	2	1	850	7/8	2-1/8	6	2	99-7/8	27-3/8	49-1/4	509
	CW6D142*TA	30	3	1	850	7/8	2-1/8	8	3	139-7/8	27-3/8	49-1/4	682
	CW6D175*TA	30	3	1	850	1-1/8	2-1/8	8	3	139-7/8	27-3/8	49-1/4	682
	CW6D189*TA	30	4	1	850	1-1/8	2-1/8	10	4	179-7/8	27-3/8	49-1/4	1050
	CW6D233*TA	30	4	1	850	1-1/8	2-1/8	10	4	179-7/8	27-3/8	49-1/4	1050
4 FPI	CW4D029*TA	30	1	1	850	1/2	1-1/8	4	1	59-7/8	27-3/8	49-1/4	303
	CW4D041*TA	30	1	1	850	1/2	1-3/8	4	1	59-7/8	27-3/8	49-1/4	303
	CW4D050*TA	30	1	1	850	5/8	1-5/8	4	1	59-7/8	27-3/8	49-1/4	303
	CW4D060*TA	30	2	1	850	5/8	1-5/8	6	2	99-7/8	27-3/8	49-1/4	509
	CW4D082*TA	30	2	1	850	7/8	2-1/8	6	2	99-7/8	27-3/8	49-1/4	509
	CW4D103*TA	30	2	1	850	7/8	2-1/8	6	2	99-7/8	27-3/8	49-1/4	509
	CW4D126*TA	30	3	1	850	7/8	2-1/8	8	3	139-7/8	27-3/8	49-1/4	682
	CW4D155*TA	30	3	1	850	1-1/8	2-1/8	8	3	139-7/8	27-3/8	49-1/4	682
	CW4D167*TA	30	4	1	850	1-1/8	2-1/8	10	4	179-7/8	27-3/8	49-1/4	1050
	CW4D206*TA	30	4	1	850	1-1/8	2-1/8	10	4	179-7/8	27-3/8	49-1/4	1050

* Each asterisk represents a variable character based on voltage ordered. See page 4 for nomenclature.

[^] For units with mounted TXV components. See Nozzle/TXV table for distributor connection size when TXV is field installed.

1. For dimensional distance between hanger slots, consult model's corresponding dimension drawing. Hanger slots are 1" deep x 1/2" wide.

2. Drain is 1-1/4" NPT for all models.

SPECIFICATIONS // LOW TEMPERATURE ELECTRIC AND HOT GAS DEFROST: 3-PHASE MOTOR

Model No.	Fan Diam. (In.)	Motor Data			Refrigerant Connections			No. of Hanger Slot Locations	Figure	Unit Dimensions (In.)			Approx. Unit Wt. (Lbs.)	
		Motor Qty.	HP	RPM	Liquid Line [^]	Suction	3-Pipe Hot Gas Line			L	W	H		
6 FPI - RW*E/G/H/K/L	CW6*036*TA	30	1	1	850	1/2	2-1/8	1-1/8	4	1	59-7/8	27-3/8	49-1/4	303
	CW6*047*TA	30	1	1	850	1/2	2-1/8	1-1/8	4	1	59-7/8	27-3/8	49-1/4	303
	CW6*059*TA	30	1	1	850	5/8	2-1/8	1-1/8	4	1	59-7/8	27-3/8	49-1/4	303
	CW6*072*TA	30	2	1	850	5/8	2-1/8	1-1/8	6	2	99-7/8	27-3/8	49-1/4	509
	CW6*096*TA	30	2	1	850	7/8	3-1/8	1-1/8	6	2	99-7/8	27-3/8	49-1/4	509
	CW6*120*TA	30	2	1	850	7/8	3-1/8	1-1/8	6	2	99-7/8	27-3/8	49-1/4	509
	CW6*143*TA	30	3	1	850	1-1/8	3-1/8	1-3/8	8	3	139-7/8	27-3/8	49-1/4	682
	CW6*179*TA	30	3	1	850	1-1/8	3-1/8	1-3/8	8	3	139-7/8	27-3/8	49-1/4	682
	CW6*216*TA	30	4	1	850	1-1/8	3-1/8	1-3/8	10	4	179-7/8	27-3/8	49-1/4	1,050
4 FPI - RW*E/G/H/K/L	CW4*038*TA	30	1	1	850	1/2	2-1/8	1-1/8	4	1	59-7/8	27-3/8	49-1/4	303
	CW4*048*TA	30	1	1	850	5/8	2-3/8	1-1/8	4	1	59-7/8	27-3/8	49-1/4	303
	CW4*077*TA	30	2	1	850	5/8	2-5/8	1-1/8	6	2	99-7/8	27-3/8	49-1/4	509
	CW4*097*TA	30	2	1	850	7/8	3-1/8	1-1/8	6	2	99-7/8	27-3/8	49-1/4	509
	CW4*115*TA	30	3	1	850	7/8	3-1/8	1-3/8	8	3	139-7/8	27-3/8	49-1/4	682
	CW4*145*TA	30	3	1	850	1-1/8	3-1/8	1-3/8	8	3	139-7/8	27-3/8	49-1/4	682
		CW4*182*TA	30	4	1	850	1-1/8	3-1/8	1-3/8	10	4	179-7/8	27-3/8	49-1/4

* Each asterisk represents a variable character based on voltage ordered. See page 4 for nomenclature.

[^] For units with mounted TXV components. See Nozzle/TXV table for distributor connection size when TXV is field installed.

1. For dimensional distance between hanger slots, consult model's corresponding dimension drawing. Hanger slots are 1" deep x 1/2" wide.

2. Drain is 1-1/4" NPT for all models.

SPECIFICATIONS // LOW TEMPERATURE ELECTRIC AND HOT GAS DEFROST: 3-PHASE MOTOR W/ HIGH-STATIC FAN BLADES

	Model No.	Fan Diam. (In.)	Motor Data			Refrigerant Connections			No. of Hanger Slot Locations	Figure	Unit Dimensions (Inches)			Approx. Unit Wt. (Lbs.)
			Motor Qty.	HP	RPM	Liquid Line [^]	Suction	3-Pipe Hot Gas Line			L	W	H	
6 FPI - RW*E/G/H/K/L	CW6*036*HA	30	1	1-1/2	1140	1/2	2-1/8	1-1/8	4	1	59-7/8	27-3/8	49-1/4	303
	CW6*047*HA	30	1	1-1/2	1140	5/8	2-1/8	1-1/8	4	1	59-7/8	27-3/8	49-1/4	303
	CW6*059*HA	30	1	1-1/2	1140	5/8	2-1/8	1-1/8	4	1	59-7/8	27-3/8	49-1/4	303
	CW6*072*HA	30	2	1-1/2	1140	5/8	2-1/8	1-1/8	6	2	99-7/8	27-3/8	49-1/4	509
	CW6*096*HA	30	2	1-1/2	1140	7/8	3-1/8	1-1/8	6	2	99-7/8	27-3/8	49-1/4	509
	CW6*120*HA	30	2	1-1/2	1140	7/8	3-1/8	1-1/8	6	2	99-7/8	27-3/8	49-1/4	509
	CW6*143*HA	30	3	1-1/2	1140	1-1/8	3-1/8	1-3/8	8	3	139-7/8	27-3/8	49-1/4	682
	CW6*179*HA	30	3	1-1/2	1140	1-1/8	3-1/8	1-3/8	8	3	139-7/8	27-3/8	49-1/4	682
	CW6*216*HA	30	4	1-1/2	1140	1-1/8	3-1/8	1-3/8	10	4	179-7/8	27-3/8	49-1/4	1,050
4 FPI - RW*E/G/H/K/L	CW4*038*HA	30	1	1-1/2	1140	1/2	2-1/8	1-1/8	4	1	59-7/8	27-3/8	49-1/4	303
	CW4*048*HA	30	1	1-1/2	1140	5/8	2-1/8	1-1/8	4	1	59-7/8	27-3/8	49-1/4	303
	CW4*077*HA	30	2	1-1/2	1140	5/8	2-1/8	1-1/8	6	2	99-7/8	27-3/8	49-1/4	509
	CW4*097*HA	30	2	1-1/2	1140	7/8	3-1/8	1-1/8	6	2	99-7/8	27-3/8	49-1/4	509
	CW4*115*HA	30	3	1-1/2	1140	7/8	3-1/8	1-3/8	8	3	139-7/8	27-3/8	49-1/4	682
	CW4*145*HA	30	3	1-1/2	1140	1-1/8	3-1/8	1-3/8	8	3	139-7/8	27-3/8	49-1/4	682
	CW4*182*HA	30	4	1-1/2	1140	1-1/8	3-1/8	1-3/8	10	4	179-7/8	27-3/8	49-1/4	1,050

* Each asterisk represents a variable character based on voltage ordered. See page 4 for nomenclature.

[^] For units with mounted TXV components. See Nozzle/TXV table for distributor connection size when TXV is field installed.

1. For dimensional distance between hanger slots, consult model's corresponding dimension drawing. Hanger slots are 1" deep x 1/2" wide.
2. Drain is 1-1/4" NPT for all models.
3. For shipping dimensions and weights, see Shipping Information table on page 31.

PHYSICAL DIMENSIONS

Figure 1: Single Fan

Front View

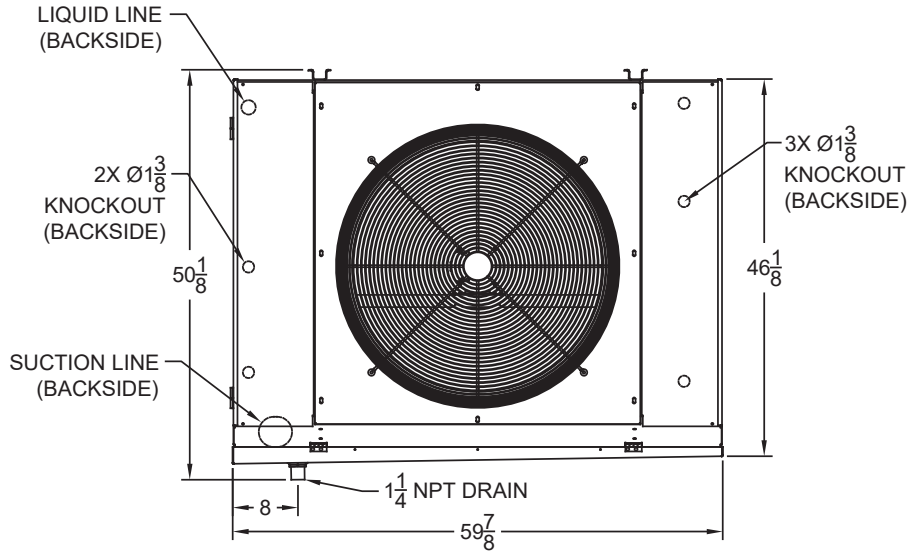

Side View

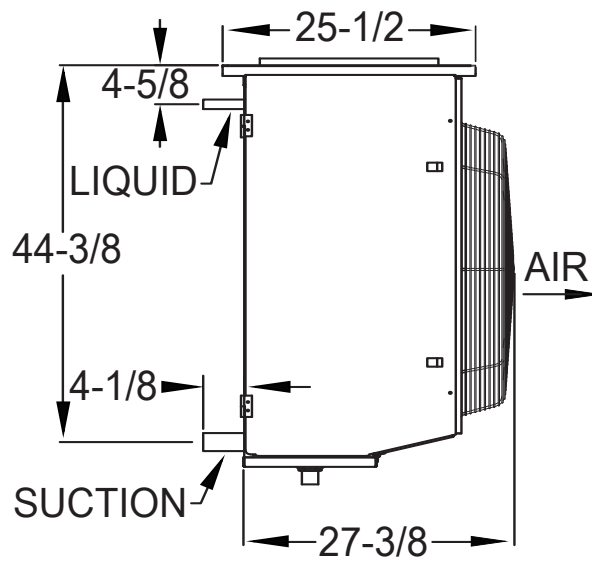

Top View

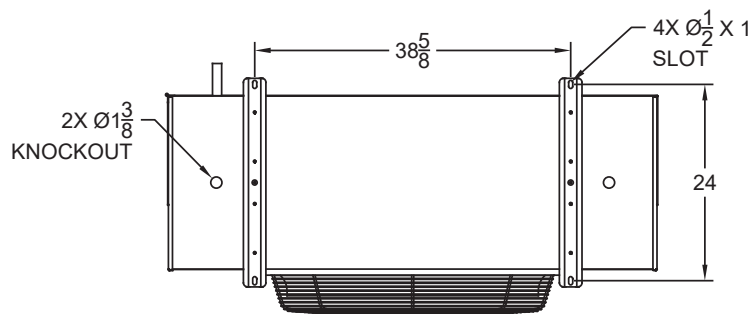

All mounting holes are 1/2" diameter.
 Mounted hanger spacers aid in the correct installation.
 All dimensions are in inches.

PHYSICAL DIMENSIONS

Figure 2: Two Fan

Front View

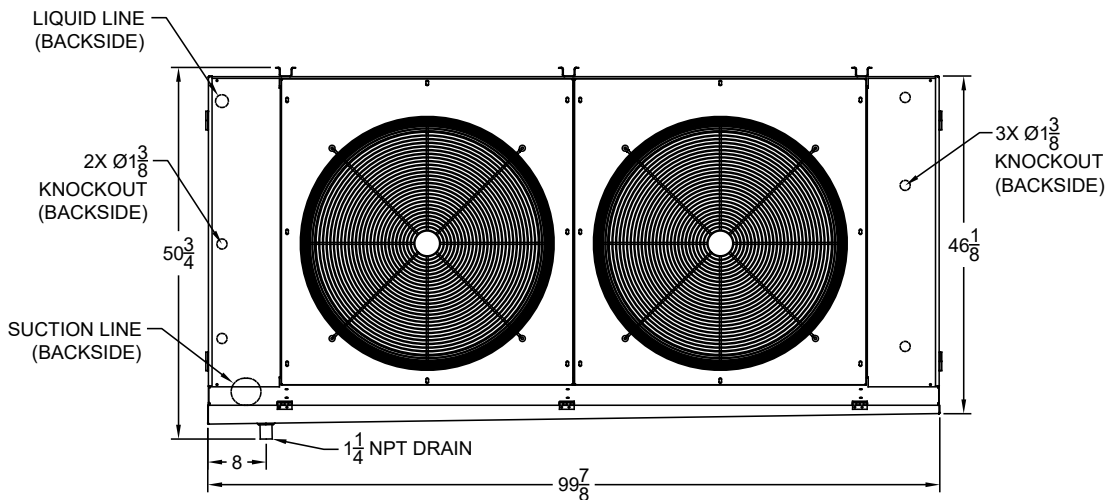

Side View

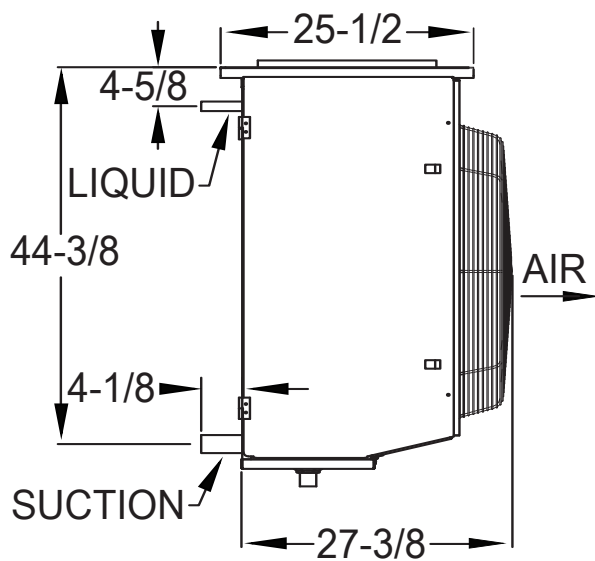

Top View

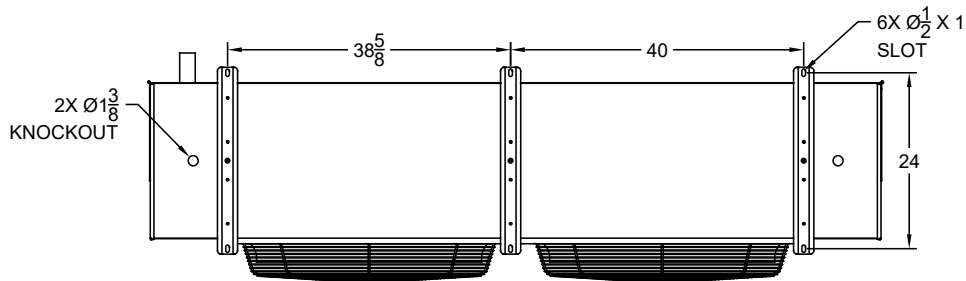

All mounting holes are 1/2" diameter.
 Mounted hanger spacers aid in the correct installation.
 All dimensions are in inches.

PHYSICAL DIMENSIONS

Figure 3: Three Fan

Front View

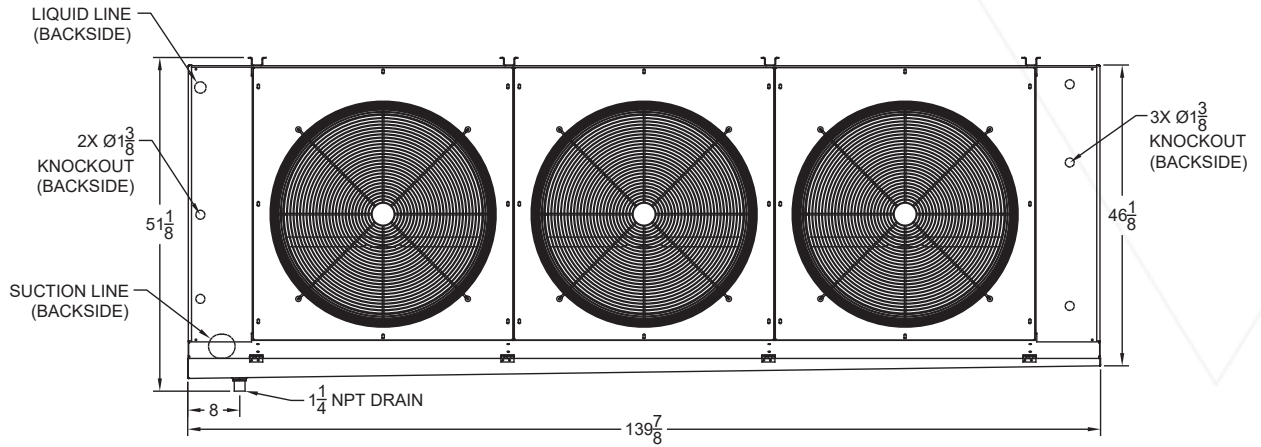

Side View

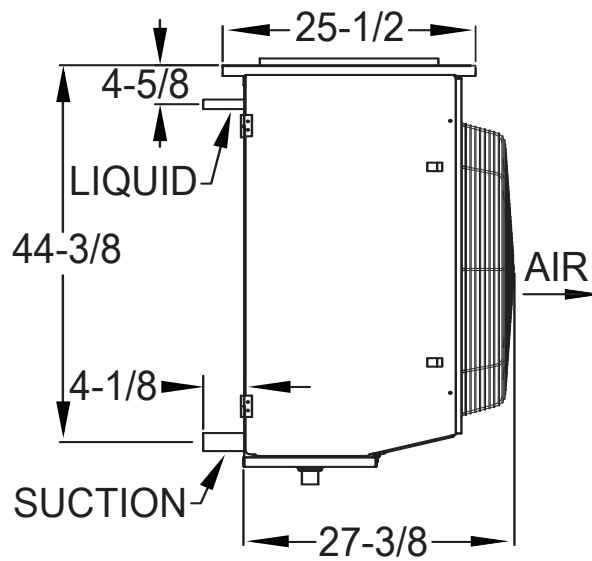

Top View

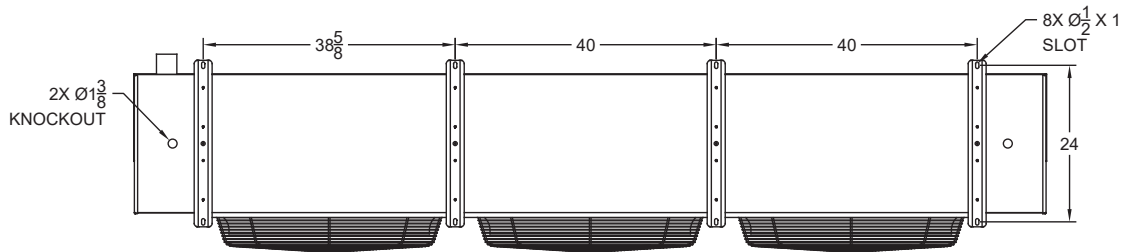

All mounting holes are 1/2" diameter.
 Mounted hanger spacers aid in the correct installation.
 All dimensions are in inches.

PHYSICAL DIMENSIONS

Figure 4: Four Fan

Front View

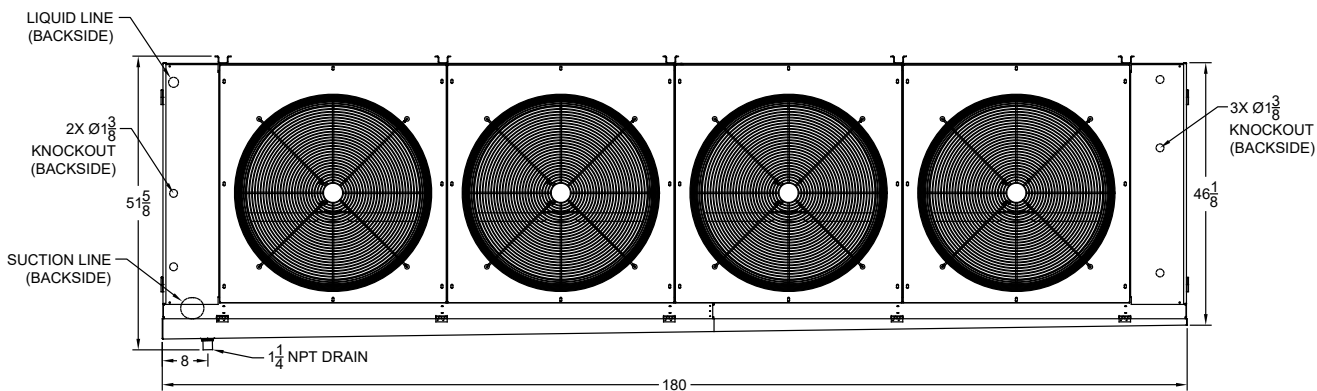

Top View

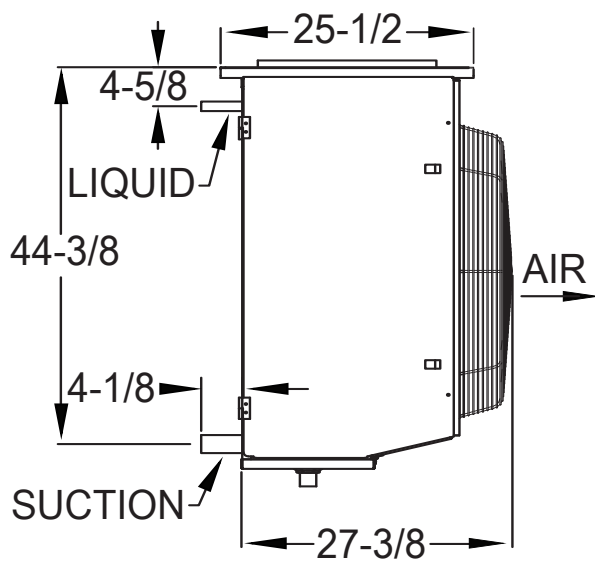

End View

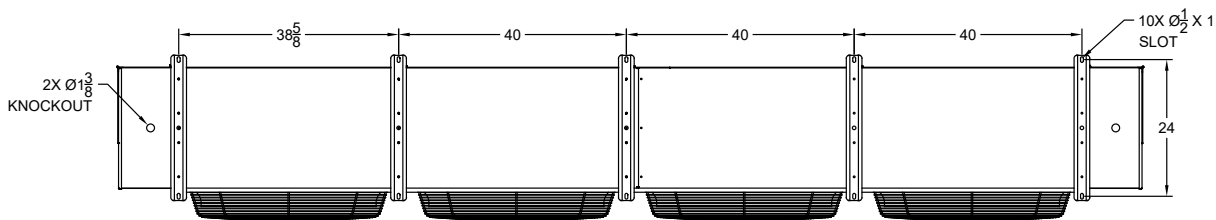

All mounting holes are 1/2" diameter.
 Mounted hanger spacers aid in the correct installation.
 All dimensions are in inches.

SHIPPING INFORMATION**Figure 1-4: Shipping information**

No. of Fans	Shipping Dimensions (In.)			Shipping Weight (Lbs)
	L	W	H	
1	69	42	66	480
2	109	42	66	750
3	146	42	66	1,030
4	189	42	66	1,360

COLDZ^oNE

ENGINEERED FOR COOL.™

©2025 Heat Transfer Products Group

Published April 2025

CZ-RWX-A1-0425

coldzone.htpg.com

This information is the most current and accurate information available and is subject to change without notice. HTPG makes no warranty or guarantee of any kind, express or implied, regarding the information set forth herein, including without limitation warranty regarding its currency, accuracy or completeness or any warranty of merchantability or fitness for a particular purpose.

