

INSTALLATION • MAINTENANCE • OPERATION

EcoNet[®] Enabled Unit Coolers

EVAPORATOR CONTROLLER



HTPG0924_IOM

CONTENTS

Introduction and Board Layout	3
Safety Considerations	4
System Installation	5
Start-Up/Commissioning	8
General Settings	10
Status Screens	11
Basic Settings	12
Lead/Lag Settings	18
Defrost Settings	14
Auxiliary Relay Settings	16
Digital Input Settings	17
BACnet MS/TP Settings	20
Replacing Legacy EcoNet Controller with New EcoNet Controller	22
Operational Overview	23
Diagnostics	25
Group Operation	26
Door Switch	28
Compressor Control (Packaged Refrigeration Units)	32
Defrost Pump Down Delay	34
Leak Detection	36
Lead/Lag	40
Operational Limits	48
Replacement Parts	48
Addendums	49-58
A: Controller Sensor Information	49
B: Electronic Valve Wiring	53
C: BACnet Objects List	55

INTRODUCTION

EcoNet Enabled Unit Coolers are intelligent, electronically operated evaporators for walk-in coolers and freezers designed for easier installation and energy savings. Developed in conjunction with Rheem Manufacturing, it builds on the success, reliability, and efficiency of the EcoNet technology and brings it to commercial refrigeration.

EcoNet Enabled Unit Coolers save energy in refrigeration systems through precise superheat and space temperature control, fan cycling, and controlling how often the system goes into defrost based on compressor runtime.

It eliminates unnecessary defrosts, maximizes energy efficiency with less compressor runtime, reduces liability by eliminating icing issues, reduces fan speed to 50% during off cycle to save energy, and reduces temperature fluctuations by regulating defrosts for improved product quality. EcoNet Enabled Unit Coolers can be configured to work on a single or dual evaporator coil and can be used with a condensing unit in single and multiple evaporator installations as a group.

ECONET BOARD

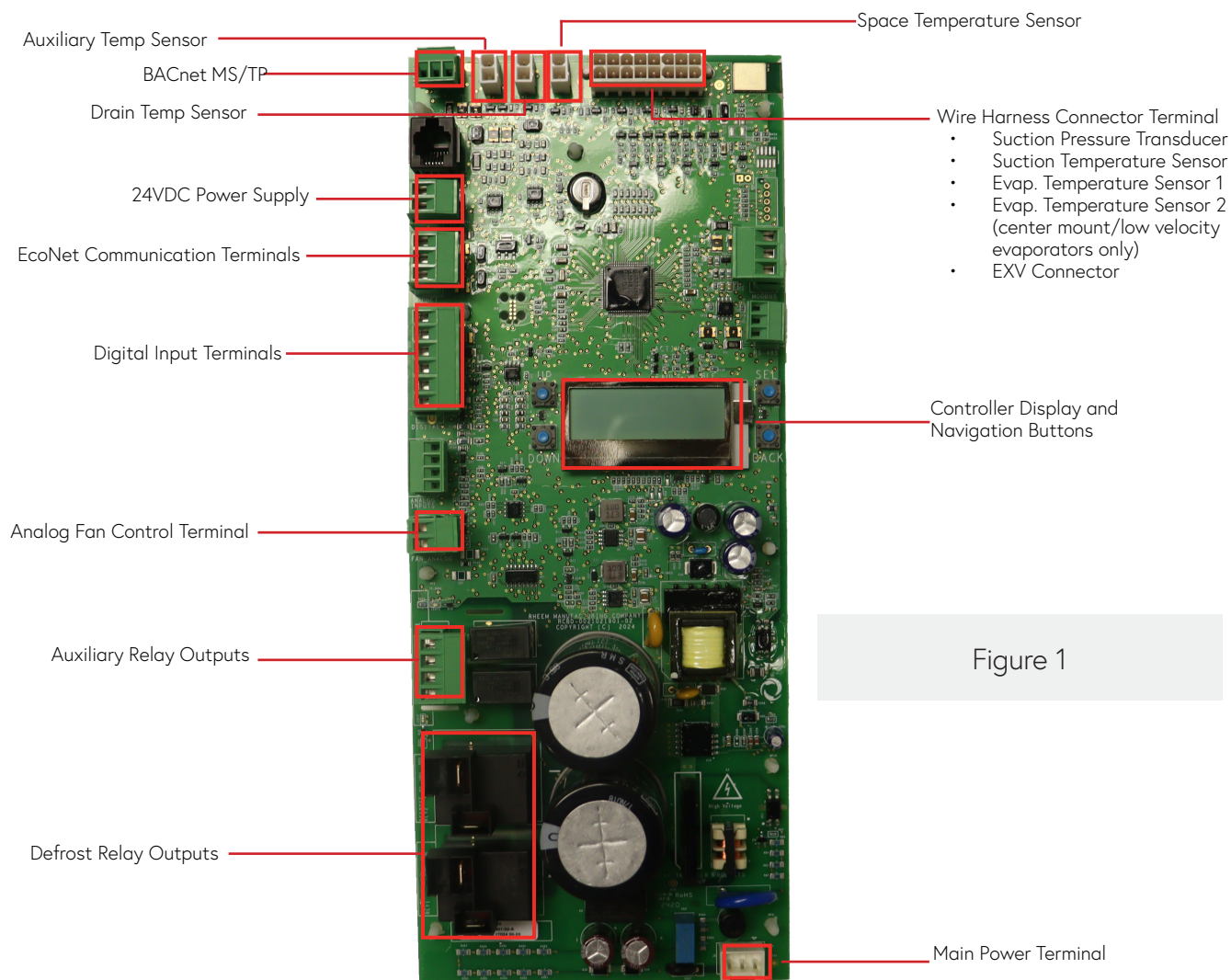

Figure 1

SAFETY CONSIDERATIONS

Failure to read and follow all instructions carefully before installing or operating this control and system could cause personal injury and/or property damage.

NOTES: All wiring must comply with national, local, and state codes.

Before service, power to the unit should be disconnected per proper lockout procedures.

After power is disconnected wait 5 minutes before touching the board for power stored to fully discharge.

The control board has no user serviceable parts, do not try to repair.

Do not wire the control board while powered.

If the board becomes corroded replace immediately. Cleaning of the control board is not recommended.

SYSTEM INSTALLATION

EVAPORATOR

- EcoNet Enabled Unit Coolers ship with the EcoNet controller installed and all sensors and relays wired. Prior to installation, you must verify that all sensors, defrost heaters and wire harnesses are securely connected to the controller board and terminal board.
- Connect main power to the evaporator unit at the L1/L2 and GND terminals on the terminal board as shown in the wiring diagram (Figures 1 & 2).

EcoNet controller supports 230 VAC or 115 VAC, 50/60 Hz power supply. Controller will automatically detect voltage and operate accordingly.

⚠ CAUTION: If changing the supply voltage from 115 to 230 VAC, wait until the board is completely drained and no lights are visible before applying new power supply, or damage to controller may occur.

WARNING: Disconnect power to the outdoor and indoor units before beginning installation

- Only a trained service professional/contractor should use or interact with the control board.
- Except for the display navigation buttons, never touch the control board surface directly to avoid static shock damage or exposure to high voltages.

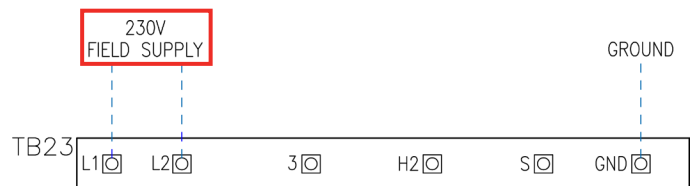

Figure 2

Main Power L1/L2 Terminals

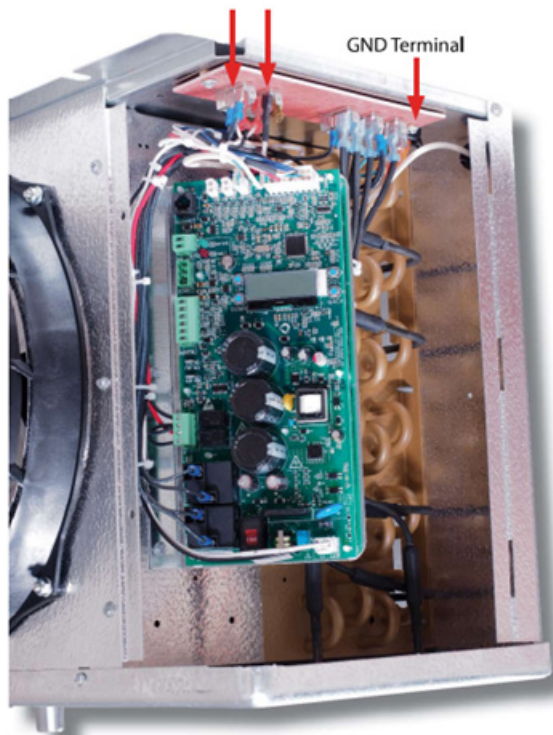

Figure 3

NOTE: If the controller loses power, it will close the EXV automatically.

- Prior to installation, please refer to factory label at evaporator unit for correct voltage and amp draw requirements to verify circuit breaker size where unit will be connected to.

CONDENSING UNIT

1. If a defrost timer is installed on the condensing unit, make sure it is disconnected/ disabled (all switches on time clock should be in the OFF position) (Figure 4). All defrost functions are performed by the controller board.
2. Please refer to factory label at condensing unit for correct voltage and amp draw requirements.

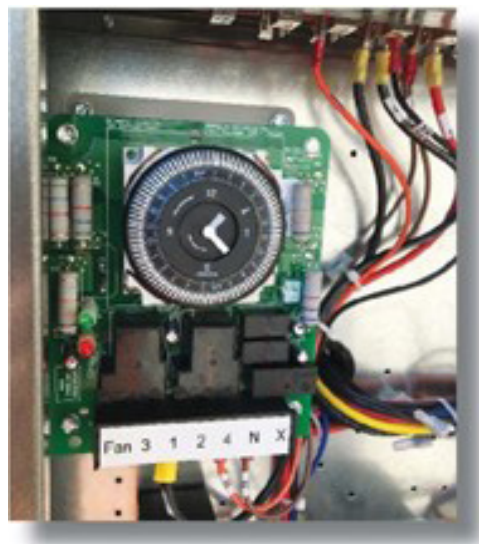

Figure 4

DURING SYSTEM INSTALLATION

1. Refrigerant Line Brazing

- a. Cover EXV with wet rag to protect from excess heat from torch.
- b. Suction Temp Sensor (Figure 5) must be removed from the suction line prior to brazing. The sensor must be reinstalled on the suction line (10 or 2 o'clock position) after brazing is completed and the tubing has been allowed to cool down. Secure the Suction Temp thermistor to suction line as shown in Figure 5. After suction temp sensor is installed, suction line should be insulated, and the sensor should be covered with the insulation.

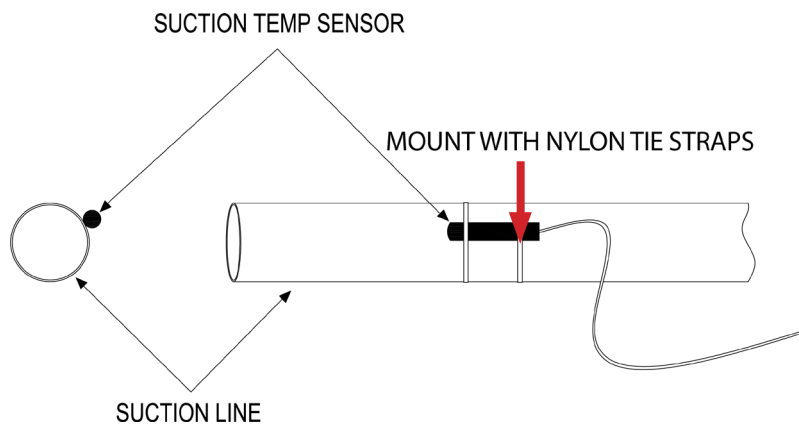

Figure 5

2. Purging Lines (pulling vacuum), two options:

- a. To purge lines on system with EXV closed, make sure that controller is off, and pull vacuum from both suction and discharge ports at the condensing unit.
 - b. OR, to purge lines on system with EXV open, power up the controller and wait a couple of minutes for the controller to command the valve to open. Leave controller powered on while system evacuation is being done.
3. While charging the system with refrigerant, ensure that the EXV is open by powering up the controller and waiting a couple of minutes for the controller to command the EXV to open. With the controller powered on while the system is being charged, make sure to monitor the suction pressure, suction temperature, and superheat via the controller display and also via installer's gauges. Please refer to Display Status under the Start-Up/Commissioning section to show on the controller display the current suction temperature, suction pressure, EXV position and calculated superheat.

NOTES:

If there is a power loss at any time during normal system operation, the controller will close the EXV, forcing a pumpdown.

When starting up the system for the first time, the controller will turn the fans on when the Evap Temp gets below a preset temperature.

4. Power Supply
 - a. Please refer to factory label on evaporator and condensing unit for MCA/MOPD ratings. If powering up evaporator on same circuit as condensing unit, please refer to evaporator wiring diagram on cover panel for compressor lockout terminal wiring (if available).

START UP | COMMISSIONING

1. Local Display (Figure 6)
 - a. Use the **UP/DOWN/SEL/BACK** buttons to navigate through the display.
 - b. To change a parameter, navigate to it using the UP/DOWN buttons, press SEL to have selection start flashing intermittently, use the UP/DOWN buttons to cycle through the selection, then press SEL again to confirm the selection.

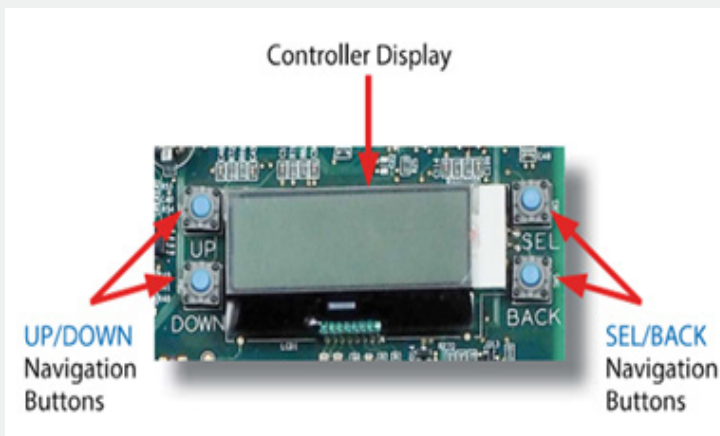

Figure 6

2. Navigation Overview

a. Main Screen



b. Settings Overview - see page 10

c. Status Overview - see page 11

d. Service

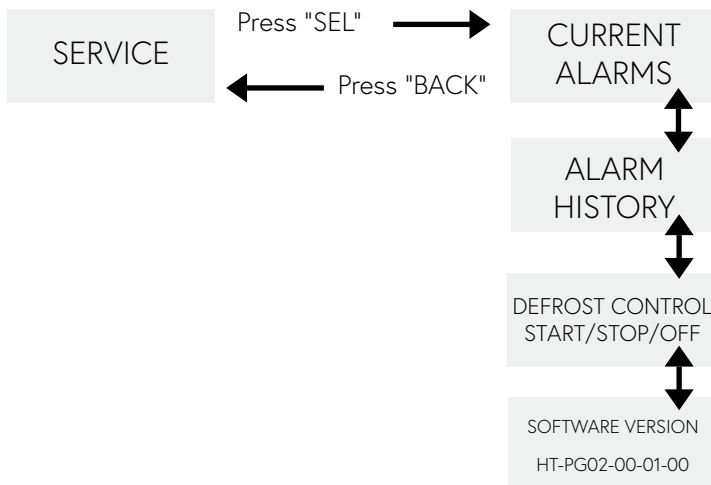

b. SETTINGS OVERVIEW

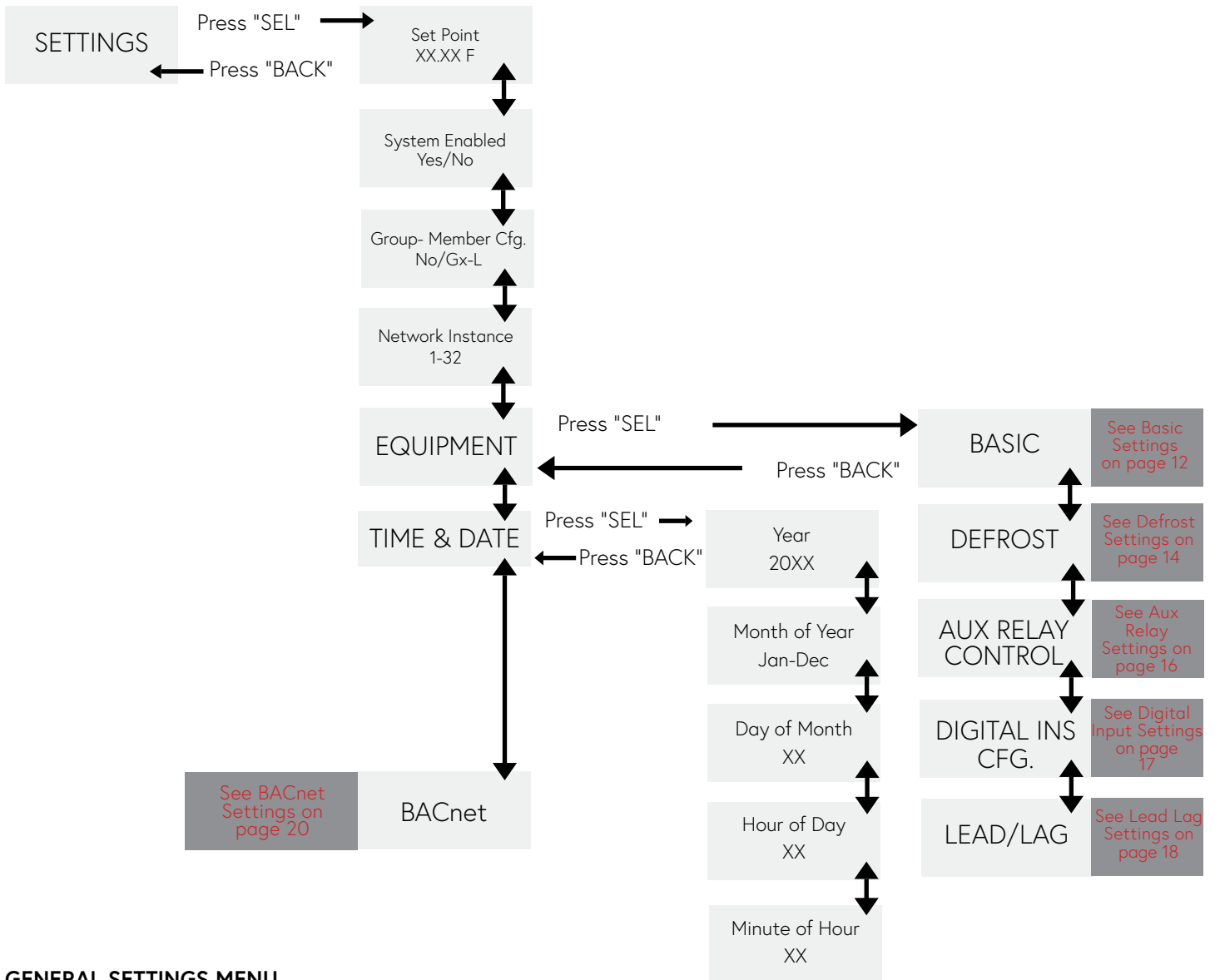

GENERAL SETTINGS MENU

BASIC SETTINGS	RANGE	DEFAULT	DESCRIPTION
Set Point	Freezer: -40°F to 60°F; Cooler: 25°F to 60°F	-10°F for Freezer; 35°F for Cooler	Configure the desired temperature setpoint. This setting is synced between Leader and Followers in a Group, and also between Manager and Partner controllers in Lead-Lag operation.
System Enabled	Yes/No	Yes	Set to YES to enable controller cooling operation. Set to NO to force system pump down; controller will close the EEV and turn the fans off. Allows for system pump down while controller is still powered on. NOTE: There is no time limit on this setting; make sure System Enable is set back to YES to allow controller to resume cooling operation.
Group Member Cfg	*See group member list on page 26	No	This setting is to address the controller as part of a group if multiple evaporators will be wired together to cool the same space. See Group Operation section on page 26 for more details.
Network Instance	1 - 32	1	This setting is to address the controller to work as a standalone unit, but wired to other evaporators on the same communication bus with a Command Center Display.
Equipment	-	-	See Equipment Settings section starting on page 12 for details.
Time and Date	-	-	Configure hour, minute, day, month and year on the controller for Alarm History time stamp.
BACnet	-	-	See BACnet MS/TP section on page 20 for configuration details.

c. STATUS OVERVIEW

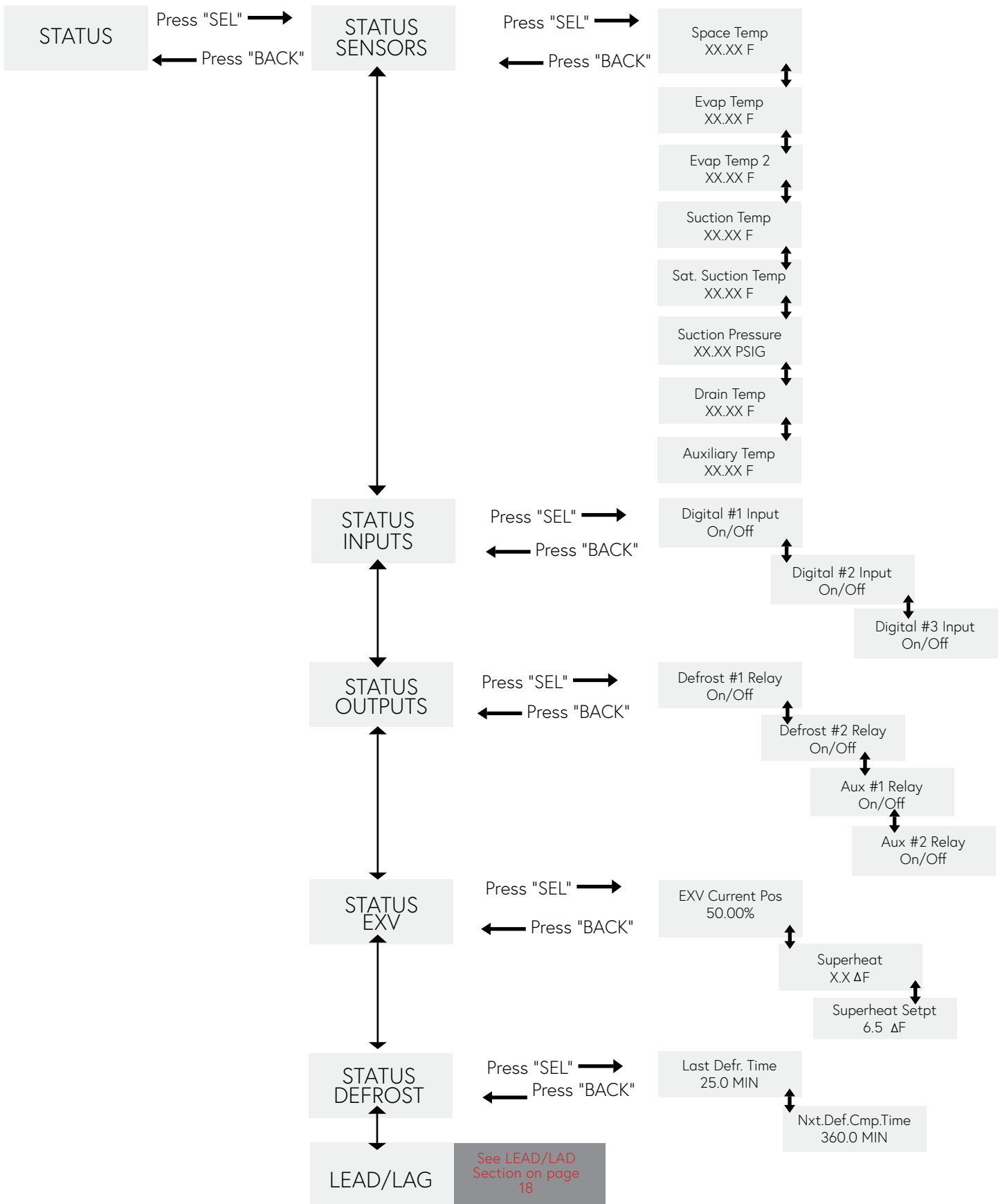

d. BASIC SETTINGS OVERVIEW

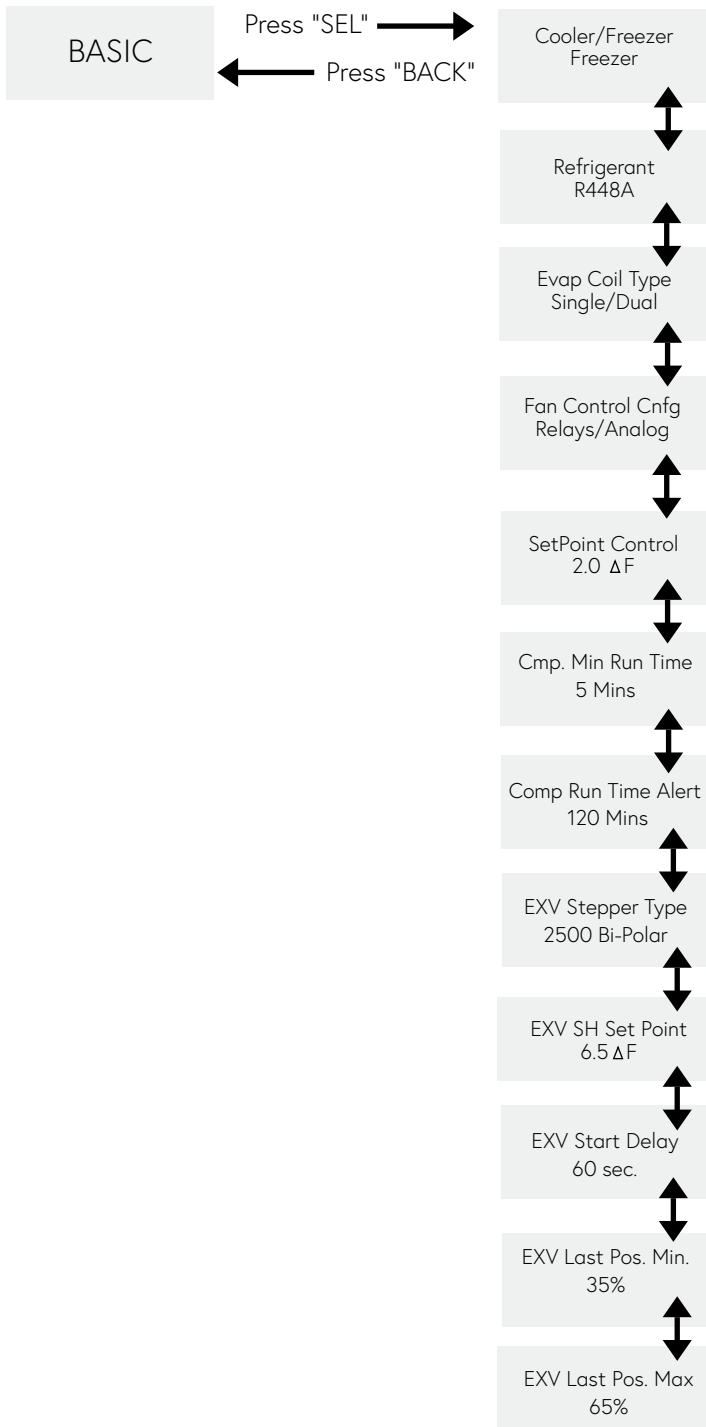

SUPPORTED REFRIGERANTS
R404A
R407A
R407C
R448A (Default)
R449A
R450A
R507A
R513A
R454C*
R455A*
R454A*
R22
CO ₂ **
R454B*
R32*

*Leak Detector required for A2L evaporator models.
 **700 PSI transducer required (HTPG part no. 08540186)

NOTE:
 See Leak Detection section on Page 36 for details

Figure 7

EXV STEPPER TYPE	APPLICABLE VALVE MAKE & MODEL
2500 Bi-Polar	Sporlan SER
480 Bi-Polar	***Carel E2V, E3V, E4V
2600 Bi-Polar	***Sanhua VPF
500 Uni-Polar	Sporlan OEV OR ***Sanhua LPF

***Check with Applications Engineering for availability.

BASIC SETTINGS MENU

BASIC SETTINGS	RANGE	DEFAULT	DESCRIPTION
Cooler/ Freezer	Cooler or Freezer	Freezer	Set the controller for the type of operation it will be used in. If set as "Freezer", the controller will use the defrost relays to activate the electric heaters in the evaporator and allow a drain time at the end of the defrost cycle. If set as "Cooler", the unit will operate as air defrost (off-cycle).
Refrigerant	*See Refrigerants table on page 12	R448A	Set the refrigerant that will be used in the system from among the list of supported refrigerants. See page 12 for list of refrigerants.
Evap Coil Type	Single or Dual	Single	Set for the type of evaporator being used. "Single" applies to Low Profile, Medium Profile, Warehouse, Heavy Duty and Packaged Refrigeration Units. "Dual" applies for Center Mount/Low Velocity evaporators where Evap Temp 2 sensor is used.
Fan Control	Relays or Analog	Relays	Configure the evaporator fan motor type to be used. "Relays" will have the controller use the Aux Relays to control the fan motor; "Analog" will have the controller use the Analog Output port to control the evaporator fan motor (check with HTPG Applications Engineering for analog fan motor availability).
Setpoint Control	0.5 to 20.0 dF	2.0 dF	Set to configure desired hysteresis range for space temperature control. When the system is in Refrigeration mode, if the Setpoint is -10F with a default Setpoint Control of 2.0 dF, the unit will continue to cool the space until Space Temp reaches -10F. When Space Temp rises above -8F, the controller will start a new cooling cycle.
Cmp. Min Run Time	3 min; 4 min; 5 min	5 min	Adjust the minimum compressor run time for each cooling cycle. When refrigeration mode starts, the system will run for the minimum time that has been configured, regardless of space temperature having reached setpoint.
Cmp. Run Time Alert	0 to 480 mins.	120 min	Set to configure the allowed refrigeration run time until a temperature alarm is flagged. If the unit is on an active refrigeration cycle for longer than this period, the "A108 Cooler/Freezer not Satisfying Setpnt. Alert" will be generated to indicate that the system has not achieved setpoint.
EXV Stepper Type	2500 Bi-Polar; 480 Bi-Polar; 2600 Bi-Polar; 500 Uni-Polar	2500 Bi-Polar	Configure the stepper valve type used with the controller. This setting will be configured at the factory on new evaporators to match the valve that is installed. Refer to the list on page 12 for each valve manufacturer. See Addendum B for valve wiring pinout information.
EXV SH Setpoint	4.0 to 20.0 dF	6.5 dF	Set to configure desired superheat setpoint.
EXV Start Delay	0-255 sec.	60 sec.	When a cooling cycle starts, the controller will open and hold the EXV at a fixed position for this delay duration. After the delay, the EXV will start modulating position to reach superheat setpoint.
EXV Last Pos. Min.	15% - 100%	35%	When a cooling cycle starts, the controller will open and hold the EXV to the last known position from the previous cooling cycle, but no less than the EXV Last Pos. Min. setting and no more than the EXV Last Pos. Max. setting. The controller will not allow this setting to be greater than EXV Last Pos. Max. setting.
EXV Last Pos. Max	65% - 100%	65%	When a cooling cycle starts, the controller will open and hold the EXV to the last known position from the previous cooling cycle, but no less than the EXV Last Pos. Min. setting and no more than the EXV Last Pos. Max. setting. The controller will not allow the EXV Last Pos. Min. setting to be greater than this setting.

e. DEFROST SETTINGS OVERVIEW

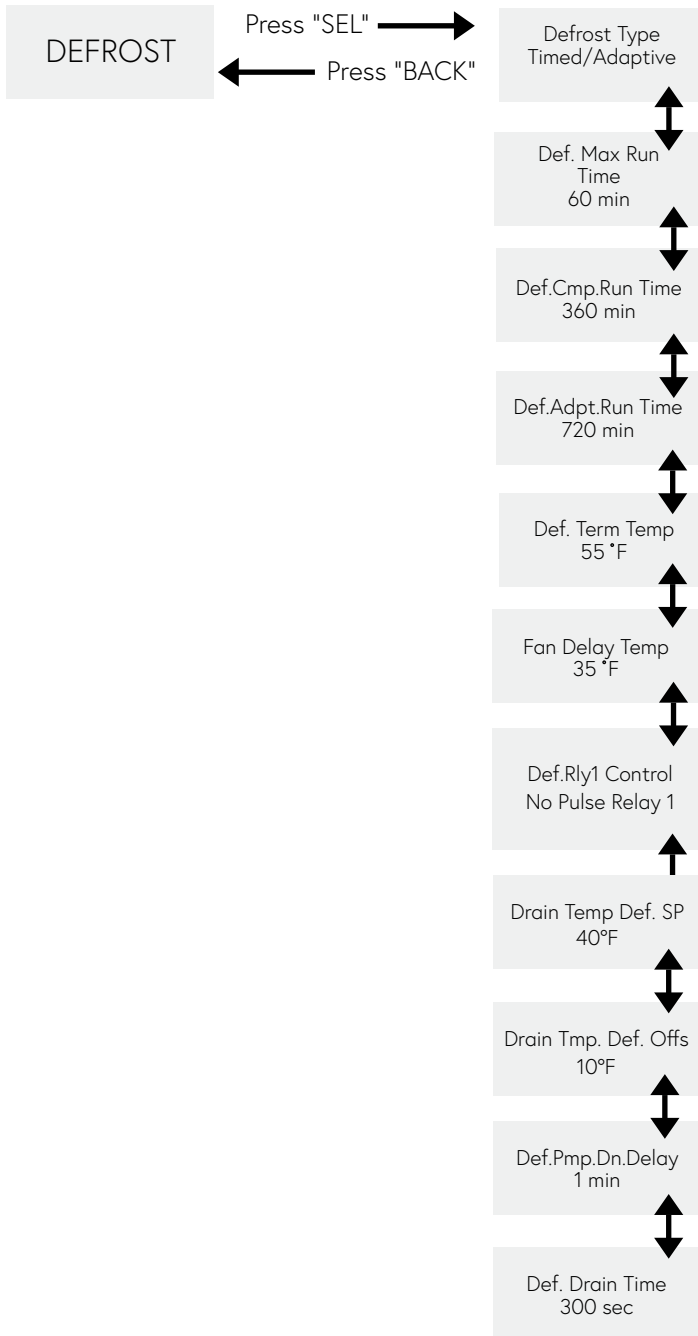

DEFROST SETTINGS MENU

DEFROST SETTINGS	RANGE	DEFAULT	DESCRIPTION
Defrost Type	Timed; Adaptive	Timed	Select desired defrost algorithm: Timed or Adaptive. Note: Adaptive defrost only applies if controller is set to Freezer. If controller is set to Cooler, Timed defrost will always remain as the functional setting. See Defrost Mode section on page 23 for more information.
Def. Max Run Time	10-60 min	60 min	Set to configure the maximum allowed defrost time.
Def. Cmp. Run Time	0-900 min	360 min	Set to configure the allowed compressor run time before the unit goes into defrost when controller is set to Timed Defrost. See Defrost Mode section on page 23 for more information.
Def. Adpt. Run Time	360-900 min	720 min	Set to configure allowed compressor run time before unit goes into defrost when controller is set to Adaptive Defrost. See Defrost Mode section on page 23 for more information.
Def. Term. Temp	35°F - 65°F	55°F (Freezer); 40°F (Cooler)	Sets the Defrost Termination Temperature; the temperature that the evaporator must reach to terminate the defrost cycle. Note: if the Cooler/Freezer setting is manually adjusted, the Defrost Termination Temp setting will revert to default (55°F for Freezer, 40°F for Cooler); if a value other than default is desired, make sure that Cooler/Freezer is set prior to adjusting the Defrost Termination Temperature.
Fan Delay Temp	25°F - 70°F	35°F (Freezer); 55°F (Cooler)	Sets the temperature that the evaporator must reach before allowing the fans to run during an active cooling cycle. Note: if the Cooler/Freezer setting is manually adjusted, the Fan Delay Temp setting will revert to default (35°F for Freezer, 55°F for Cooler); if a value other than default is desired, make sure that Cooler/Freezer is set prior to adjusting the Fan Delay Temperature.
Def. Rly 1 Control	No Pulse Relay 1; Drain Pan Defrost	No Pulse Relay 1	A. No Pulse Relay 1: relay remains continuously on for the duration of the electric defrost cycle. B. Drain Pan Defrost: relay will cycle on and off depending on Drain Temperature sensor. Note: Drain Temp sensor must be installed and connected, otherwise the controller will alarm "A104 Drain Temp Thermistor Failure" and keep the relay on for the duration of the defrost cycle. See Page 24 for more details.
Drain Temp Def. SP	20°F-80°F	40°F	When Defrost Relay 1 Control is set to "Drain Pan Defrost", this is the cut-in setpoint for Defrost Relay 1. See page 24 for more details.
Drain Tmp Def. Offs.	1°F - 20°F	10°F	When Defrost Relay 1 Control is set to "Drain Pan Defrost", this is the cut-out offset for Defrost Relay 1. See page 24 for more details.
Def. Pmp. Dn. Delay	0 - 5 min	1 min	Set desired delay for pump down before electric heaters become active at the start of an electric defrost cycle. See page 34 for more details.
Def. Drain Time	0 - 600 sec	300 sec	Adjust the drain time duration following an electric defrost cycle.

f. AUX RELAY SETTINGS OVERVIEW

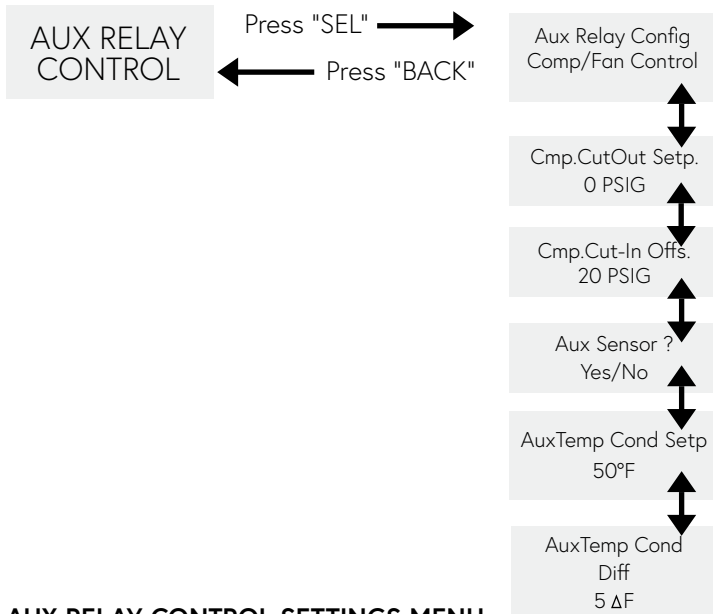

AUX RELAY CONTROL SETTINGS MENU

AUX RELAY CONTROL	RANGE	DEFAULT	DESCRIPTION
Aux Relay Config	Comp/Fan Control; Fan Control; Cmp/Cond Control; Alarm/Alert OUT; None	Comp/Fan Control	<p>Configure how the Aux Relays on the controller will be used:</p> <p>A. Comp/Fan Control: controller will use Aux Relay 1 for evaporator fan on/off control, and Aux Relay 2 for compressor on/off control. Note: This setting is for Packaged Refrigeration Systems with dual speed evaporator fan motor. See Packaged Refrigeration System section on page 32 for more details.</p> <p>B. Fan Control: controller will use Aux Relays 1 and 2 for evaporator fan on/off and speed control. Not for use with Packaged Refrigeration Systems!!!</p> <p>C. Cmp/Cond Control: controller will use Aux Relay 1 for condenser fan speed control, and Aux Relay 2 for compressor on/off control. Note: This setting is intended for Packaged Refrigeration Systems with analog fan motor on the evaporator. Under this setting, the evaporator fan is controlled by the Analog Output port. Please check with Application Engineering for analog fan motor availability.</p> <p>D. Alarm/Alert OUT: controller will turn on Aux Relay 1 if there is a critical alarm active, and Aux Relay 2 if there is a non-critical alert active. Note: Under this setting, the evaporator fan is controlled by the Analog Output port. Please check with Application Engineering for analog fan motor availability.</p> <p>E. None: Aux Relays are not used.</p>
Cmp. Cut Out Setpoint	-5 PSIG to 60 PSIG	0 PSIG (Freezer); 20 PSIG (Cooler)	Pressure setpoint at which the compressor (Aux Relay 2) will turn off when Aux Relay Config. is set to either Comp/Fan Control or Cmp/Cond Control. Please refer to Packaged Refrigeration System section on page 32 for more details. Note: if the Cooler/Freezer setting is manually adjusted, the Cut-Out Setpoint setting will revert to default (0 PSIG for Freezer, 20 PSIG for Cooler); if a value other than default is desired, make sure that Cooler/Freezer is set prior to adjusting the Cut-Out Setpoint.
Cmp. Cut In Offset	10 PSIG to 50 PSIG	20 PSIG	Pressure differential for compressor (Aux Relay 2) to turn on when Aux Relay Config. is set to either Comp/Fan Control or Cmp/Cond Control. Please refer to Packaged Refrigeration System section on page 32 for more details.
Aux Sensor?	Yes/No	No	Configure Aux Temperature sensor for Aux Relay 2 condenser fan speed control. This setting only applies if Fan Control is set to "Analog" for evaporator fans and Aux Relay Config. is set to "Cmp/Cond Control." Please check with Application Engineering for analog fan motor availability.
Aux Temp Cond Setp.	0°F to 80°F	50°F	Temperature setpoint for Aux Temp sensor to cycle condenser fan to low speed on a Packaged Refrigeration System. This setting only applies if Fan Control is set to "Analog" for evaporator fans and Aux Relay Config. is set to "Cmp/Cond Control." Please check with Application Engineering for analog fan motor availability.
Aux Temp Cond Diff.	2°F to 40°F	5°F	Temperature differential setpoint for Aux Temp sensor to cycle condenser fan to high speed on a Packaged Refrigeration System. This setting only applies if Fan Control is set to "Analog" for evaporator fans and Aux Relay Config. is set to "Cmp/Cond Control." Please check with Application Engineering for analog fan motor availability.

g. DIGITAL INS CFG. SETTINGS OVERVIEW



DIGITAL INPUT SETTINGS MENU

DIGITAL INS CFG.	RANGE	DEFAULT	DESCRIPTION
Door Sw. Config.	Off/N.O./N.C.	Off	Configure the use of a door switch on Digital Input #1 to be either Normally Open (N.O.) or Normally Closed (N.C.). Default setting is Off. Please refer to Door Switch section on page 28 for more details.
Door Sw. Time	0 sec/30 sec/1 min/2 min/3 min/4 min/5 min	0 sec	If using a door switch, this setting adjusts the delay for the "T003 Door Open Alert" notification to appear and the system to pump down. Please refer to Door Switch section on page 28 for more details.
Leak Sw. Config.	Off/N.O./N.C.	N.O.	Configure the use of a leak detector device on Digital Input #2 to be either Normally Open (N.O.) or Normally Closed (N.C.). Please refer to Leak Detection section on page 36 for more details.

h. LEAD/LAG SETTINGS SUB-MENU OVERVIEW

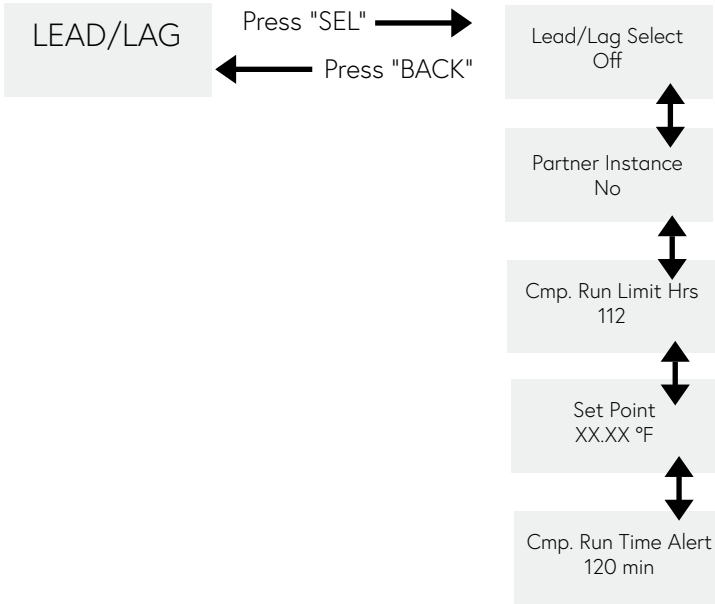

i. LEAD/LAG STATUS SUB-MENU

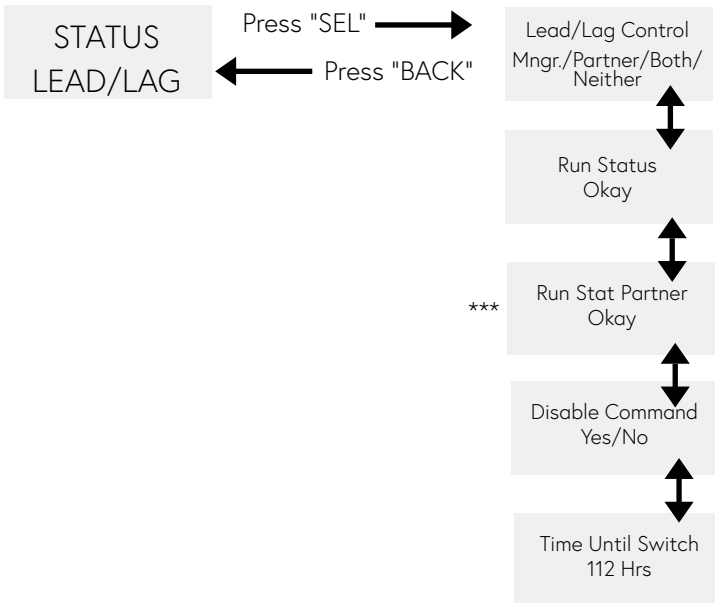

*** Visible only if controller is set to Lead/Lag Manager.

LEAD/LAG SETTINGS MENU

LEAD/LAG	RANGE	DEFAULT	DESCRIPTION
Lead/Lag Select	Off/Manager/Partner	Off	Configure the controller to be either the Manager or the Partner on a lead/lag setup, or None for no lead/lag control. Please refer to Lead/Lag section on page 40 for more details.
Partner Instance	No,1-32,G1,G2,G3,G4	No	At the Manager controller, select the Instance number of the Partner controller that will be paired for lead/lag operation. Please refer to Lead/Lag section on page 40 for more details.
Cmp. Run Limit Hrs.	16 to 240 hours in increments of 16, then 240 to 960 hours in increments of 80	112 hours	Configure the amount of run time hours that must elapse until cooling functions are switched between the Manager and Partner units to equalize compressor run time between the two. Please refer to Lead/Lag section on page 40 for more details.
Set Point	Freezer: -40°F to 60°F; Cooler: 25°F to 60°F	-10°F for Freezer; 35°F for Cooler	Configure the desired temperature setpoint. This setting is configured at the Manager controller and is automatically synced to the Partner controller.
Comp. Run Time Alert	0 to 480 min	120 min	Configuration for the allowed refrigeration run time until the "A108 Cooler/Freezer not Satisfying Setpnt. Alert" is flagged. If the active unit (Manager or Partner) is on a refrigeration cycle for longer than this period, this alarm will be generated to indicate that the box has not been able to achieve setpoint. Under Lead/Lag operation, this alarm will signal the inactive backup unit (Manager or Partner) to assist to meet refrigeration demand. This setting is configured at the Manager controller and is automatically synced to the Partner controller.

j. BACNET MS/TP OVERVIEW

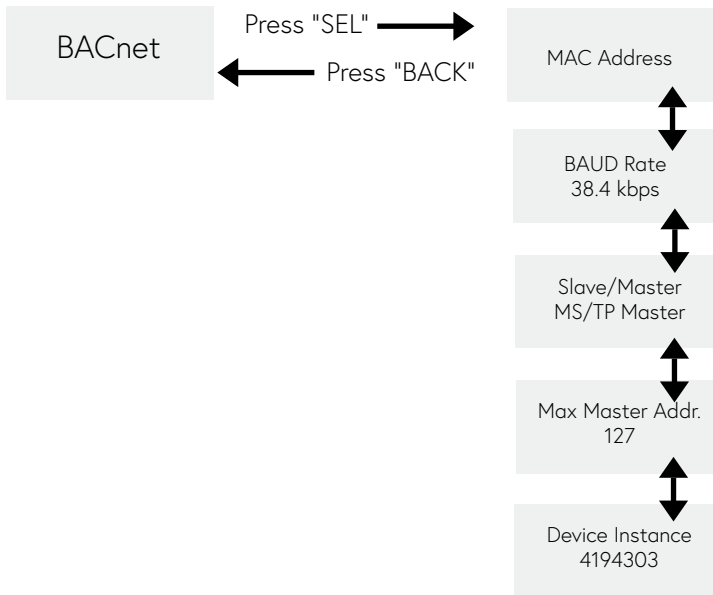

BACNET SETTINGS MENU

BACNET SETTINGS	RANGE	DEFAULT	DESCRIPTION
MAC Address	0 - 127 (Master); 0-254 (Slave)	1	MAC address must be unique among all devices on a given BACnet network segment. MAC address 0 should be avoided.
BAUD rate	9.6 kbps; 19.2 kbps; 38.4 kbps; 57.6 kbps; 76.8 kbps	38.4 kbps	The rate at which data is communicated to the devices. Please make sure that all the devices on the BACnet MS/TP network are set to the same BAUD rate.
Slave/Master	MS/TP Master; MS/TP Slave	MS/TP Master	EcoNet controller should always remain set to MS/TP Master.
Max Master Addr.	0 - 127	127	The maximum MAC address among the devices on a network segment. Qualified technicians may adjust this value to improve performance.
Device Instance	0000000 - 4194303	4194303	The default value 4194303 indicates unassigned instance, and cannot be used in operation. Instance must be assigned for use. Must be unique across devices on all BACnet network segments of the BACnet internetwork.

BACNET SETTINGS CONFIGURATION AND DEVICE WIRING MUST BE PERFORMED BY A QUALIFIED TECHNICIAN.

FOR MORE INFORMATION, PLEASE VISIT [HTTPS://WWW.ASHRAE.ORG/](https://www.ashrae.org/)

BACNET SETTINGS CONFIGURATION AND DEVICE WIRING MUST BE PERFORMED BY A QUALIFIED TECHNICIAN.

FOR MORE INFORMATION, PLEASE VISIT [HTTPS://WWW.ASHRAE.ORG/](https://www.ashrae.org/)

PINOUT

TERMINAL	DESCRIPTION
P	RS-485 Positive (+)
N	RS-485 Negative (-)
RT	Common (for use when RS-485 port is optically isolated)

BACnet Communication Terminal

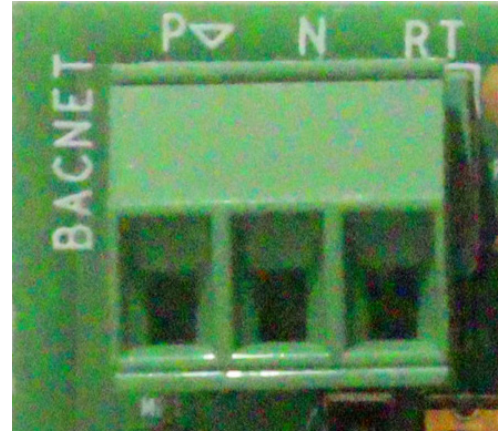

REPLACING LEGACY ECONET CONTROLLER WITH NEW ECONET CONTROLLER

If retrofitting new EcoNet controller on existing Unit Cooler, configure the following settings to match the existing system:

1. Under Basic Settings (see pages 12-13)
 - a. Cooler/Freezer
 - b. Refrigerant
 - c. Set Evap Coil Type to "Dual" if using Center Mount/Low Velocity evaporator.
 - d. Set Fan Control to "Relays"
 - e. Set EXV Stepper Type to "2500 Bi-Polar" for Sporlan SER valve
2. Under Defrost Settings (see pages 14-15)
 - a. Set Defrost Type
 - b. Set Defrost Max Time
 - c. Set Runtime for Timed or Adaptive defrost
 - d. Set desired Defrost Termination Temp
 - e. Set desired Fan Delay Temp
 - f. Set Def. Relay 1 Control to "No Pulse Relay 1"
 - g. Set desired Defrost Pump Down Delay
 - h. Set Defrost Drain Time (if Freezer)
3. Under Aux Relay Control (see page 16)
 - a. Set Aux Relay Config to "Fan Control" for Unit Coolers, or "Comp/Fan Control" for Packaged Refrigeration Units
 - b. Set Cut-Out Setpoint, Cut-In Offset for Packaged Refrigeration Units
4. Under Digital Ins Cfg. (see page 17)
 - a. Set Door Sw. Config and Door Sw. Time if using a Door Switch
 - b. Set Leak Sw. Config to "N.O." if using a leak detector (A2L evaporators only).
5. Under Settings (see General Settings, page 10)
 - a. Setpoint
 - b. Group Member Cfg.
 - c. Network Instance

OPERATIONAL OVERVIEW

REFRIGERATION MODE

When the controller is powered up it will go through an initial startup procedure driving the EXV closed to ensure the valve is properly sealed. After 1 minute, if the space temperature is higher than the Space Temp Setpoint, the controller will start a cooling cycle and open the EXV in an attempt to cool the space.

During normal refrigeration mode, the EXV will continuously modulate to maintain superheat setpoint. The evaporator fans will turn on when Evap Temp drops below the Fan Delay Temp setting. To prevent compressor short cycling, the active refrigeration mode will run for a minimum of 5 minutes (adjustable via Cmp. Min Run Time; see pages 12-13 for Basic Settings).

When the space temperature drops below the Space Temp Setpoint, the EXV will close forcing a pump down, and the fans will cycle to half speed. To prevent compressor short cycling, this inactive mode will run for a minimum of 2 minutes.

When the space temperature rises 2 degrees above the Setpoint (can be adjusted via Setpoint Control parameter, see pages 12-13 for Basic Settings), the EXV will open again and then fans will cycle back to full speed.

DEFROST MODE

TIMED DEFROST (DEFAULT SETTING)

With the controller set to Timed defrost, the defrost start time will vary depending on compressor run time. The controller will automatically start defrost when the Def. Comp. Run Time has elapsed (default 360 minutes), or manually when set by the user on the display [Service→Defrost Control→Start Defrosting](#).

NOTE: When the unit is actively cooling the space (EXV is metering, fans running at full speed) the controller is counting runtime towards the next defrost. When the space temperature setpoint is satisfied (EXV closes for pumpdown, fans running at half speed) the controller does not count this as runtime towards the next defrost.

ADAPTIVE DEFROST (OPTIONAL SETTING)

With Adaptive defrost selected, the controller continuously monitors coil operation as indicated by EXV position over time and by temperatures. When both EXV and temperature conditions degrade past a certain point, the controller will automatically start a defrost cycle. Otherwise, a defrost will be started anyway after the Def. Adpt. Run Time (default 720 minutes) has expired. Alternatively, a defrost can be manually started by the user via the display by navigating to [Service→Defrost Control→Start Defrosting](#).

NOTE: Adaptive defrost is only available when the controller is set to Freezer. If the controller is set to Cooler, Timed defrost will always remain as the functional setting.

When a defrost cycle starts, the EXV will close for pumpdown.

If unit is set as "Freezer", the electric heaters will be energized via the defrost relays after a short delay (if Defrost Pump Down Delay is configured), and the fans will cycle off. Defrost will end when evaporator coil reaches termination temperature or when Max. Defrost Run Time has elapsed (whichever comes first). The unit will then begin a 5-minute drain time. After the drain time has finished, the unit will resume normal refrigeration operation: EXV opens, and fans turn on when Evap Temp drops below Fan Delay Temp setting.

If unit is set as "Cooler" the fans will remain on after the EXV has closed. Defrost will end when evaporator coil reaches termination temperature or when Max. Defrost Run Time has elapsed (whichever comes first). After the defrost cycle ends, the unit will resume normal refrigeration operation: EXV opens and fans will run when Evap Temp drops below the Fan Delay Temp setting.

NOTE: If there is a power loss while the unit is in the middle of an automatic defrost cycle, the controller will keep the EXV closed. When power is restored, the controller will go through its initial startup before resuming the defrost cycle. When the defrost cycle ends, the controller will resume refrigeration functions.

DEFROST RELAY 1 CONTROL (DRAIN PAN HEATER PULSING ON LOW-PROFILE MODELS ONLY)

- Defrost Relay 1 needs to be wired to Drain Pan Heater, while Defrost Relay 2 gets wired to Top and Bottom heaters.
- No Pulse Relay 1: Defrost Relay 1 stays On continuously during the Defrost Cycle.
- Drain Pan Defrost: Defrost Relay 1 will turn ON while Defrost Mode is "Defrosting" and Drain Temp is less than Drain Temp Def. Setpoint. Defrost Relay 1 will turn OFF while Defrost Mode is "Defrosting" and Drain Temp is greater than Drain Temp Def. Setpoint + Drain Temp Def. Offset.
- Only applies when controller is configured as Freezer
- If Drain Temp sensor is disconnected while controller is configured to Drain Pan Defrost, the controller will flag "A104 Drain Temp Thermistor Failure" and keep Defrost Relay 1 on for the duration of the electric defrost cycle.

RECOMMENDED FREEZER DEFROST PARAMETER SETTINGS

- Low Profile Evaporators: Set Defrost Termination Temperature between 55°F and 65°F.
- Center Mount Evaporators: Set Defrost Termination Temperature between 35°F and 40°F (adjust as necessary if defrost cycle is too long and steaming occurs); Coil Type should be set to Dual.
- If defrost cycle is too long, keep in mind that the Max Defrost Time can also be adjusted down to terminate defrost before steaming occurs. Default is 60 minutes.
- If more defrost cycles are desired, the Runtime Until Defrost can be adjusted down so the unit will defrost more often throughout the day. Default is 360 minutes (6 hours of runtime).

DIAGNOSTICS

The following alarms and alerts can be flagged by the controller. When a critical alarm is active, the controller will flash a red LED above the display. When the alarm condition is no longer true, the alarm will clear and the red LED will stop flashing. The alarm will remain logged in the Alarm History. Non-critical alerts also get logged in the Alarm History, but do not cause the red LED to flash when active.

NON-CRITICAL ALERTS:

- T001 Defrost Failure: Max Time Expired (If Freezer)
- T003 Door Open Alert

CRITICAL ALARMS:

- A004 Refrigerant Leak Detect Alarm
- A005 Lead/Lag Communication Failure
- A100 Suction Temp Thermistor Failure
- A101 Evaporator Temp Sensor Failure
- A102 Evap Temp 2 Thermistor Failure
- A103 Space Temp Thermistor Failure
- A104 Drain Temp Thermistor Failure
- A105 Aux Temp Thermistor Failure
- A106 Suction Pressure Sensor Failure
- A108 Cooler/Freezer not Satisfying Setpnt. Alert
- A500 Configuration Data Restore Failure
- A502 Time Clock needs to be programmed
- A503 Time Clock not advancing time properly

GROUP OPERATION

The EcoNet application supports multiple evaporator controllers to be connected together and work under a Leader/Follower setup as shown below. A maximum of 6 evaporators (1 Leader plus 5 Followers) can be configured onto a single group, and a maximum of 4 groups can be connected onto the same communication bus (see Figure 8). When multiple controllers are addressed and connected to work as a group, the Leader of each group will command its followers when to cool the space, when to pump down, and when to start a defrost.

Each group will work from a calculated average space temperature to determine if the space needs cooling. When a group is in active cooling mode, each evaporator in the group will meter its own EXV based on its individual superheat calculation.

The Leader will keep track of the system runtime and command the Followers in its group to start a defrost cycle as necessary. When a defrost cycle ends, the Leader will command the Followers in its group to start cooling the space simultaneously after every member of the group has finished defrosting.

Each controller to be connected on the communication bus should be powered up and addressed individually before being connected to the other controllers in the daisy chain.

To address each individual controller via the display select [Settings→Group Member Cfg.](#) To "daisy chain" the units on the network, each unit should be connected to the EcoNet communication terminals (E1, E2, RT) as shown below. Use minimum 18 to 22 AWG shielded cable with shunt capacitance of 16 pF per foot and 100 ohm impedance.

Leader/Follower Wiring Diagram

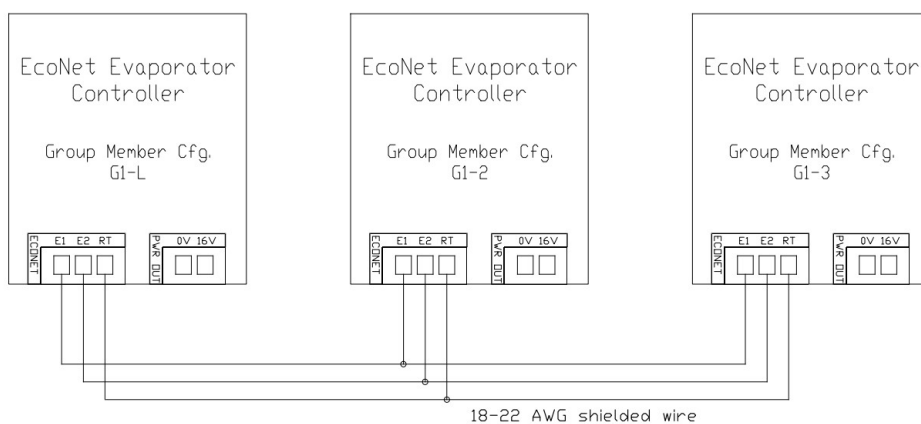

Figure 8

GROUP MEMBER CFG.	DESCRIPTION
No	Standalone Unit
G1-L	Group 1 Leader
G1-2	Group 1 Followers
G1-3	
G1-4	
G1-5	
G1-6	
G2-L	Group 2 Leader
G2-2	Group 2 Followers
G2-3	
G2-4	
G2-5	
G2-6	
G3-L	Group 3 Leader
G3-2	Group 3 Followers
G3-3	
G3-4	
G3-5	
G3-6	
G4-L	Group 4 Leader
G4-2	Group 4 Followers
G4-3	
G4-4	
G4-5	
G4-6	

When setting up a group for the first time, the following parameters only need to be set at the Leader. The Leader will broadcast these settings to any connected followers in its group.

1. Setpoint
2. Refrigerant
3. Cooler/Freezer
4. Runtime Until Defrost, Timed (Def. Cmp. Run Time)
5. Defrost Pump Down Delay
6. Defrost Type
7. Runtime Until Defrost, Adaptive (Def. Adpt. Run Time)
8. System Enabled
9. Cmp Run Time Alert
10. Setpoint Hysteresis
11. Door Switch Config.
12. Door Switch Alert Time
13. Comp. Minimum Run Time

- Ensure that communication wiring polarity is consistent on all controllers being wired together.
- A maximum of 32 devices including the Command Center can be daisy chained together on a single communication bus. If using the Web Portal with a Command Center display connected to WiFi, the maximum number of controllers connected to the Command Center is 8 (Please refer to Web Portal IOM for more details).
- Maximum wiring length of communication bus from first device to last device is 1,000 ft.
- The controllers can be wired in any order.

DOOR SWITCH

The EcoNet evaporator controller can be paired with a door switch to pump down the system and turn off the fans. Please follow the steps below to wire and configure a door switch.

1. Wiring the Door Switch

Wire door switch or toggle switch to Digital Input #1 (terminals 1A and 1B) using 18-20 AWG wire. Input is a dry contact; no external voltage source needed.

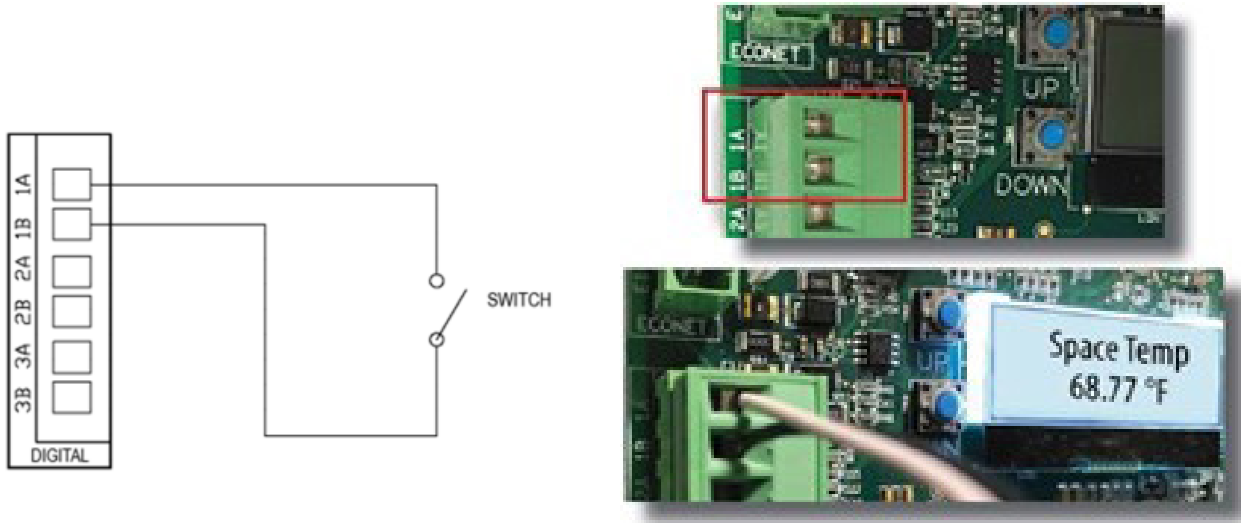

2. Configuring the Door Switch

Under Equipment, navigate to Door Sw. Config.

Press SEL button, default setting (Off) will start flashing.

Default setting is "Off"; can be configured as Normally Open (N.O.), or Normally Closed (N.C.).

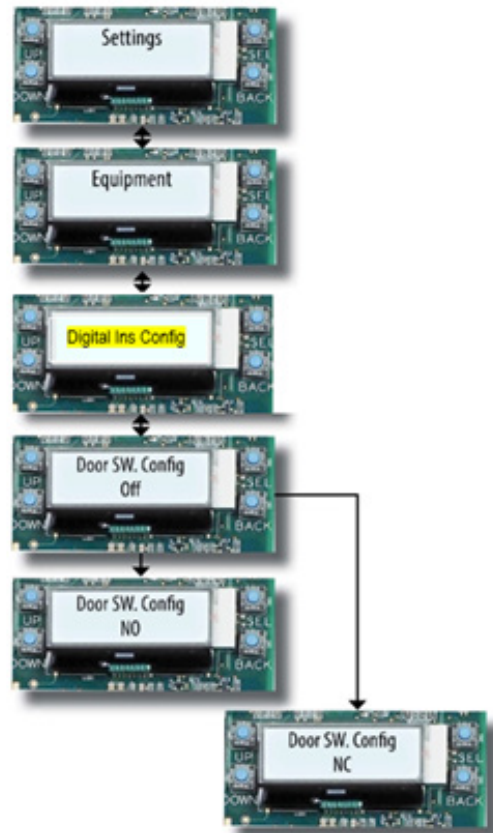

NORMALLY OPEN (N.O.) DOOR SWITCH

Active State→Closed Contact: System runs. Digital Input #1 (Door Switch Input) displayed on Status screen as ON.

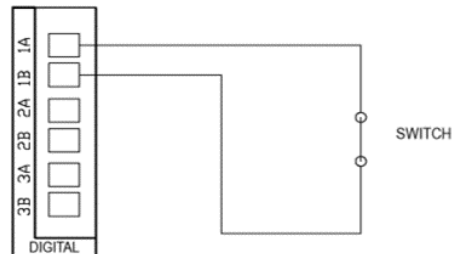

Inactive State→Open Contact: System pumps down, fans turn off, T003 Door Open Alert is generated.

Digital Input #1 (Door Switch Input) displayed on Status screen as OFF.

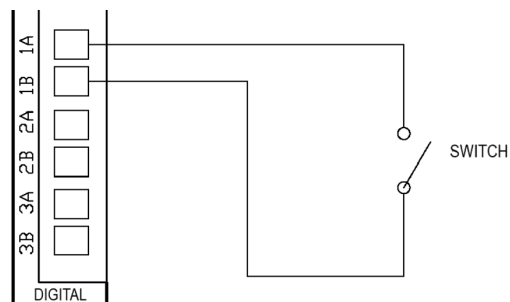

NORMALLY CLOSED (N.C.)

Active State→Open Contact: System runs. Digital Input #1 (Door Switch Input) displayed on Status screen as OFF

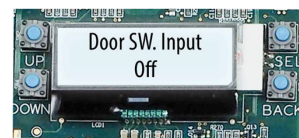
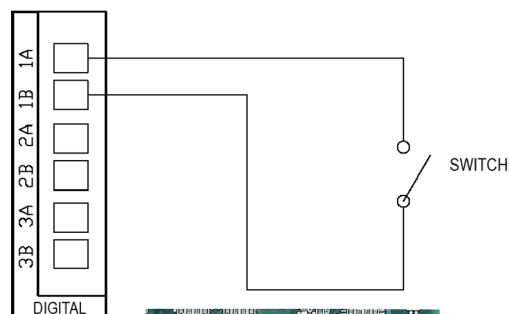

Inactive State→Closed Contact: System pumps down, fans turn off, T003 Door Open Alert is generated.

Digital Input #1 (Door Switch Input) displayed on Status screen as ON

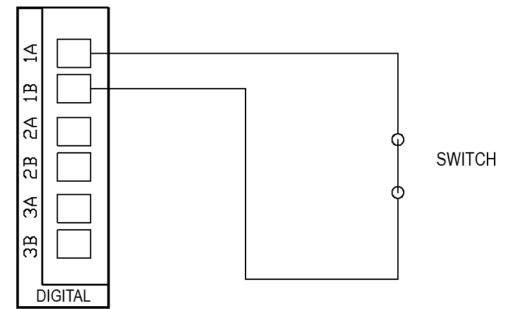

CONFIGURING DOOR SWITCH DELAY

Under Equipment, navigate to Door Sw.Time. Default 0 second delay: system will pump down and fans turn off immediately when Door Open Alert is generated.

Delay can be configured for 30 seconds, 1 minute, 2 minutes, 3 minutes, 4 minutes or 5 minutes.

With Door Switch configured as N.O. or N.C., contact has to be in its inactive state continuously for the configured Delay time before Door Open Alert is generated, system pumps down and fans turn off.

DOOR SWITCH SEQUENCE OF OPERATIONS

With Door Switch configured, T003 Door Open Alert will cause system to pump down and fans to turn off immediately when Digital Input is in its inactive state (open contact for N.O. or closed contact for N.C.).

Once system pumps down and fans turn off, a 2-minute minimum off time is observed where the EXV will remain closed regardless of Door Switch Input status.

After Digital Input changes back to its active state and remains there for 5 seconds, the T003 Door Open Alert will clear, and system will be allowed to run again.

If input changes back to its active state before the 2-minute minimum, fans will run at 50% speed. After the 2-minute minimum, cooling mode resumes (EXV opens, fans cycle to 100% speed).

If Door Open Alert is generated during a defrost cycle (Air or Electric), defrost cycle continues unaffected.

There is a mandatory 5-minute minimum cooling period following the defrost cycle, regardless of Door Switch input status.

NOTE: The Door Open Alert does not reset the Space Temperature Alarm delay timer (set by Cmp. Run Time Alert under Settings), nor does it clear the "A108 Cooler/ Freezer not Satisfying Setpnt. Alert" once it has been generated. See Cmp. Run Time Alert setting on page 13.

DOOR SWITCH SEQUENCE IN A GROUP

Only the group Leader needs the Door Switch wired and configured.

T003 Door Open Alert is generated at Leader when input is in inactive state for the configured Delay. Follower evaporators will receive pump down command from Leader and their fans will turn off.

Minimum 2 minute off time applies to entire Group. If Digital Input at Leader changes back to its active state before the 2 minutes are up, Leader and Followers will turn their fans to 50% after the Door Open Alert is cleared. After the 2 minutes have elapsed, Group resumes cooling as soon as the Door Open Alert has cleared.

If Door Open Alert is generated during a defrost cycle (Air or Electric), defrost cycle continues unaffected for the entire Group. There is a mandatory 5 minute minimum cooling period following the defrost cycle, regardless of Door Switch input status. Door Open Alert does not clear "A108 Cooler/Freezer not Satisfying Setpnt. Alert" or reset its timer count.

COMPRESSOR CONTROL

PACKAGED REFRIGERATION UNITS

The EcoNet Evaporator Controller can be set to cycle the compressor ON or OFF via Aux Relay 2 by configuring the Aux Relay Config. setting to Comp-Fan Control. The controller will use the Suction Pressure transducer reading to determine if the compressor needs to run. This setting is required for Packaged Refrigeration Units.

CONFIGURATION	ADJUSTMENT RANGE	DEFAULT SETTING
Aux Relay Config.	Comp-Fan Control;Fan Control	"Comp-Fan Control"
Cut-Out Setpoint	-2 PSIG to 60 PSIG	"0 PSIG" for Freezer units;"20 PSIG" for Cooler units
Cut-In Offset	10 PSIG to 50 PSIG	"20 PSIG"

1. Aux Relay Config.

a. *Fan Control*: Controller will use Auxiliary Relays 1 and 2 for Evaporator Fan ON/OFF control and fan speed control. **This setting is applicable for all other evaporator unit models. Not applicable for Packaged Refrigeration Units!**



b. *Comp-Fan Control*: Controller will use Auxiliary Relay 1 for Evaporator Fan ON/OFF control and Auxiliary Relay 2 for Compressor ON/OFF control based on Suction Pressure transducer reading.

NOTE: This setting only applies to Packaged Refrigeration Units. Packaged Refrigeration Units MUST be set to Comp Fan Control or damage to equipment could result!



2. *Cut-Out Setpoint*: Pressure setpoint at which the compressor will turn off when Aux Relay Config. is set to Comp-Fan Control.



3. *Cut-In Offset*: Pressure differential for compressor to turn on when Aux Relay Config. is set to Comp-Fan Control.



COMPRESSOR OPERATION

When a cooling cycle starts, the controller will open the Electronic Expansion Valve (EEV) which will cause the Suction Pressure to increase.

The compressor will turn ON when:

Suction Pressure (PSIG) is greater than Cut-Out Setpoint + Cut-In Offset. The controller will keep the compressor on for a minimum amount of time while the EEV is open, even if the Suction Pressure briefly gets below the Cut-Out Setpoint to prevent compressor from short cycling.

Example 1 (Low Temperature Unit):

Cut-Out Setpoint = 0 PSIG | Cut-In Offset= 20 PSIG

Compressor will turn ON when Suction Pressure is greater than 20 PSIG.

Compressor will turn OFF when Suction Pressure is less than 0 PSIG.

Example 2 (Medium Temperature Unit):

Cut-Out Setpoint = 20 PSIG | Cut-In Offset= 20 PSIG

Compressor will turn ON when Suction Pressure is greater than 40 PSIG.

Compressor will turn OFF when Suction Pressure is less than 20 PSIG.

When a cooling cycle ends (setpoint is satisfied, defrost starts, etc.) the controller will close the EEV and the compressor will turn OFF.

DEFROST PUMP DOWN DELAY

Configurable delay to allow compressor to pump down before electric heaters are activated at the start of a defrost cycle.

Default setting is "1-minute"; Available delay configuration of None, 1 minute, 2 minutes, 3 minutes, 4 minutes, 5 minutes.

Only applicable when controller is configured as "Freezer"; delay will have no effect if controller is configured as "Cooler."

CONFIGURING DEFROST PUMP DOWN DELAY

Under Defrost settings, scroll down to Def. Pmp. Dn. Delay.

Press SEL button, default setting (1-minute) will start flashing. Use UP or DOWN buttons to adjust to desired delay. Press SEL button again to confirm change.

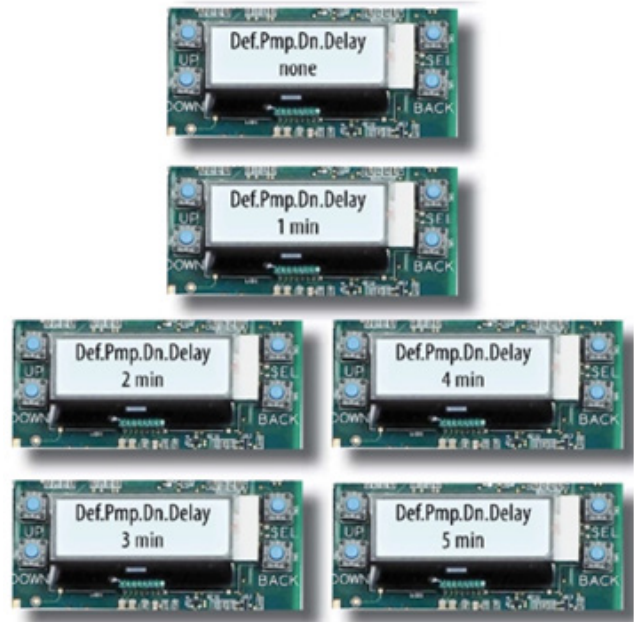

When defrost cycle starts, display will show "Initialize" for the duration of the delay. Fans cycle to 50% speed after EXV has closed.



When "Defrosting" appears on display, the heater relays are active, and fans turn off.

After defrost terminates (Due to time or temperature), drain time will follow as normal.



LEAK DETECTION

The EcoNet evaporator controller can be paired with a leak detection device to assist with mitigation procedures in case of a refrigerant leak.

NOTE: THIS FEATURE IS INTENDED FOR USE WITH A2L REFRIGERANTS (R454A,R454C, R455A,R454B,R32). REQUIRES INSTALLATION OF A LIQUID LINE SOLENOID VALVE UPSTREAM, AND A SUCTION LINE CHECK VALVE DOWNSTREAM OF THE EVAPORATOR TO INTERRUPT REFRIGERANT FLOW WHEN A LEAK IS DETECTED.

WIRING THE LEAK DETECTOR DEVICE TO THE ECONET CONTROLLER

Wire the leak detector device to Digital Input #2 (terminals 2A and 2B) using 18-20 AWG wire.

Input is a dry contact; no external voltage source needed.

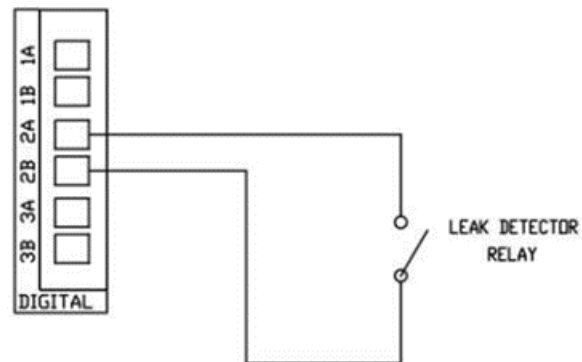

CONFIGURING THE LEAK DETECTOR INPUT

Under Equipment, navigate to Leak Sw. Config.

Press SEL button, setting will start flashing.

Use UP or DOWN buttons to adjust to desired leak detector input operation.
Press SEL button again to confirm change.

It can be configured as Normally Open (N.O.), Normally Closed (N.C.), or Off to disable leak detector input.

Note: A2L evaporator models will come with a leak detector installed and this setting configured from the factory.

NORMALLY OPEN (N.O.) LEAK DETECTOR RELAY

Active State→Closed Contact: Leak Alarm Active.

"A004 Refrigerant Leak Detect Alarm" generated.

Digital Input #2 displayed on Status screen as ON.

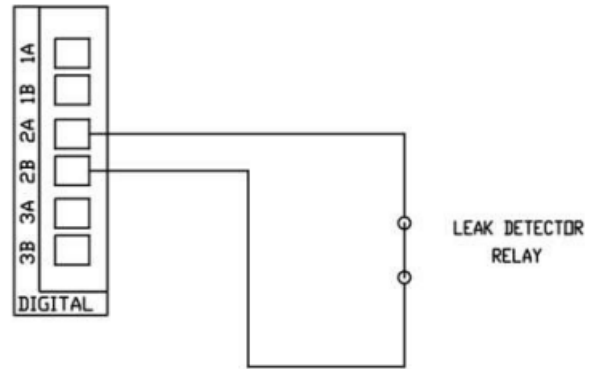

Inactive State →Open Contact: System runs.

Digital Input #2 displayed on Status screen as OFF.

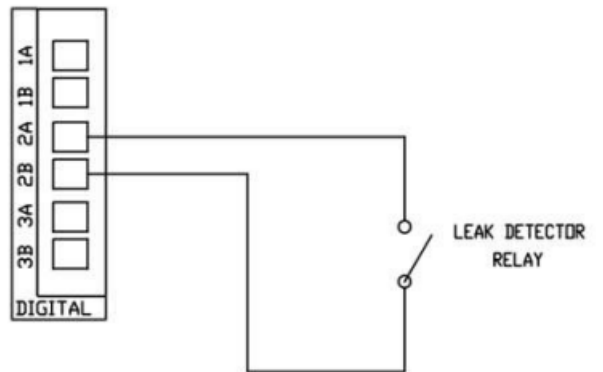

NORMALLY CLOSED (N.C.) LEAK DETECTOR RELAY

Active State→Open Contact: Leak Alarm Active.
"A004 Refrigerant Leak Detect Alarm" generated.
Digital Input #2 displayed on Status screen as OFF.

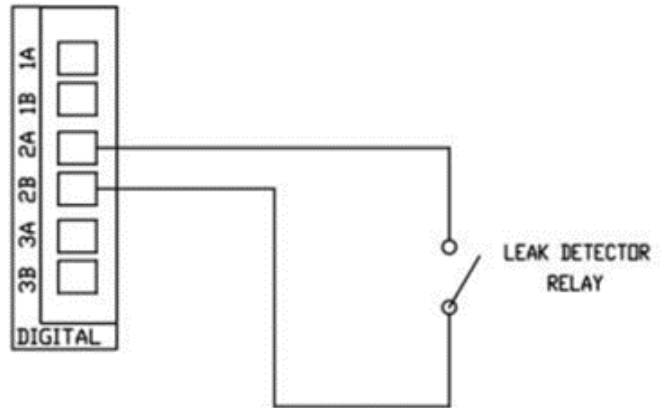

Inactive State →Closed Contact: System runs.
Digital Input #2 displayed on Status screen as ON.

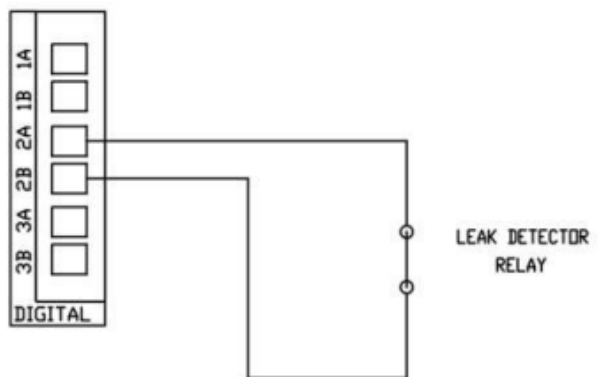

When the leak detection input (Digital Input #2) becomes active, the EcoNet controller shall do the following:

1. Keep evaporator fans turned on.
2. Electronic Expansion Valve will stay at an open position.
(Installation of solenoid and check valves required on liquid and suction lines)
3. Controller display will read "Leak Alarm Active."
4. "A004 Refrigerant Leak Detect Alarm" will appear on the active alarm screen and logged in the alarm history.
5. If Aux Relay Config. is set to Comp-Fan Control (Packaged Refrigeration Units), the Aux Relay #2 for the compressor will remain OFF.

The leak alarm condition will stay on for as long as Digital Input #2 is in its active state. If the leak detection input becomes active while the controller is undergoing a defrost cycle, the defrost cycle will be suspended.

NOTE: The leak alarm condition will also override the Door Switch and System Enable functions.

When Digital Input #2 becomes inactive, the controller will wait 10 seconds before resuming normal operation.

On group operation, each group member will generate a leak alarm only when their own individual leak detector input (Digital Input #2) becomes active.

When a group member generates a leak alarm, that group member will follow the steps described above. Other group members will also display "Leak Alarm Active" on their display screens but may continue their refrigeration functions if their respective leak detector inputs are not active.

LEAD/LAG

Lead/Lag will allow the linking of two redundant systems for backup cooling and ability to equalize compressor runtime between the two systems. This will be accomplished by designating one of the two evaporators to be the Manager, and the other evaporator to be the Partner. The controller designated to be the Manager will constantly communicate via the EcoNet communication port to the Partner controller. The Manager controller will monitor its own status as well as the Partner status and coordinate cooling operations between the two systems.

LEAD/LAG MANAGER SETUP

To configure two controllers to work under Lead/Lag operation:

1. At the designated Partner controller, set the Instance number address. See Network Instance setting on Page 10.
2. Connect 18-22 AWG shielded wire between the two controllers at the EcoNet communication port.
3. At the designated Manager controller:
 - a. Set the Instance number address. See Network Instance setting on Page 10 (must be different number from Partner).
 - b. Set **Lead/Lag Select** to "Manager"
 - c. Select **Partner Instance** number (same number configured on step #1; this is the address that the Manager will communicate with).
 - d. Set the **Compressor Run Limit Hours** to the desired switching time interval.

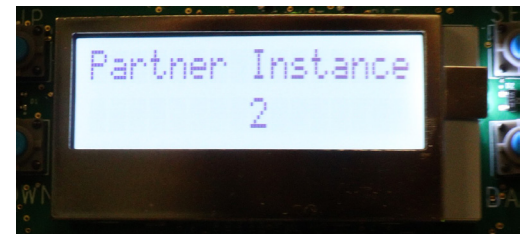

e. Set the desired temperature **Setpoint** (Manager will sync Partner to the same Setpoint)



f. Set the desired **Compressor Run Time Alert** (Manager will sync Partner to the same run time alert setting)



NOTE: Manager will also sync Partner to the same Cooler/Freezer setting.

LEAD/LAG SEQUENCE OF OPERATIONS

Once both controllers are set up and communicating, the Manager controller will keep track of compressor runtime and coordinate operational turns between the Manager and Partner controllers.

After the initial setup and synchronization the Manager controller will start first, and the Partner controller will remain disabled (EXV closed, fans off).

When the Manager controller reaches its configured Compressor Run Limit Hours it will disable (EXV closed, fans off), and the Partner controller will continue cooling operation. The Manager will receive periodic updates on the Partner run time hours, and when the Compressor Run Limit Hours are reached the Partner will be disabled and the Manager will resume cooling operations.

When the active controller (Manager or Partner) starts a defrost cycle, the inactive controller will remain disabled. When the next cooling cycle starts, the controller that underwent the defrost cycle will resume cooling operation until the Compressor Run Limit Hours are reached.

LEAD LAG INSTALLATION

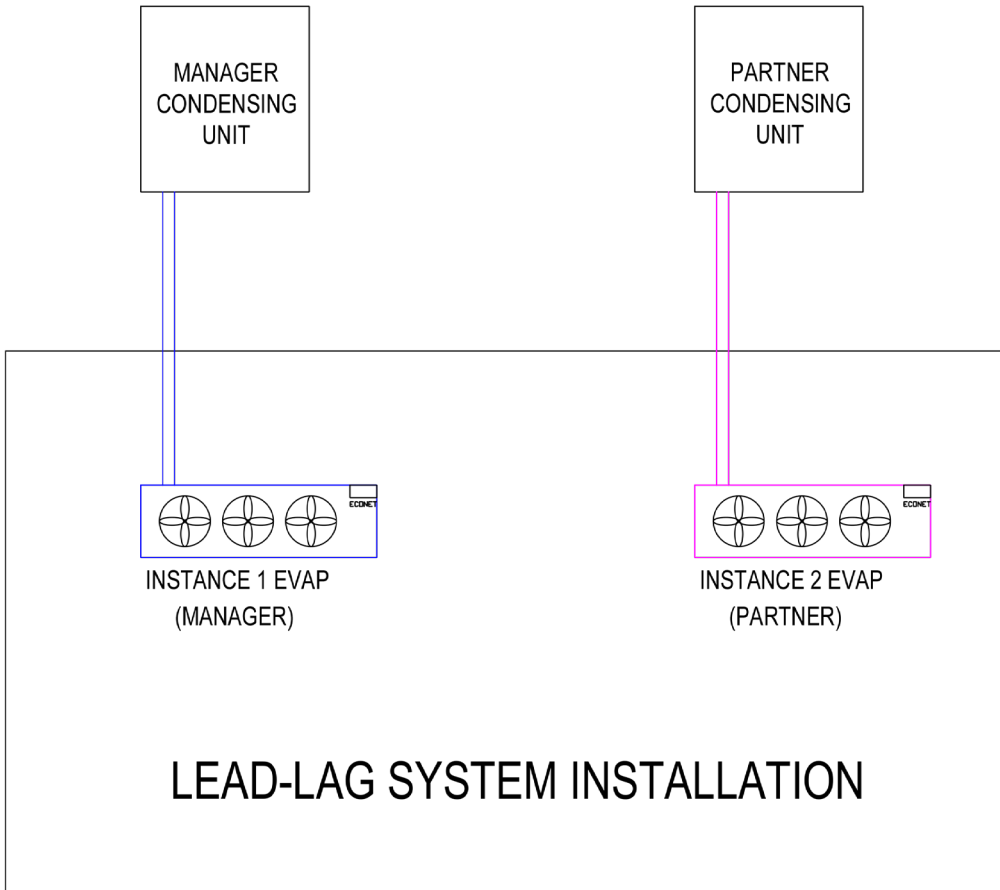

Lead Lag: 100% load requirement each compressor

LEAD/LAG IN GROUPS

Lead-Lag coordination between two different groups is handled between each of the group leaders. One Group Leader will be the Manager, and another Group Leader will be the Partner. Each Group Leader will handle its respective Group Followers as described in the Group Operation section on page 26.

To set up Lead Lag between two different groups:

1. Set up "Group Member Cfg." address for each group (i.e. Group 1 Leader and all its Followers, and Group 2 Leader and all its Followers). See Group Operation section on page 26 for details on how to set up a Group.
2. Connect communication wire in a daisy chain pattern between all controllers from both groups. They can be wired in any order.
3. On the Group Leader controller that will be the Manager:
 - a. Configure Lead Lag Select to "Manager"
 - b. Configure Partner Instance to G1, G2, G3 or G4 (the group whose leader is going to be the Partner; must be different than the Manager Group)
 - c. Configure Compressor Run Limit Hours
 - d. Set the desired Setpoint (Manager Group Leader will sync this setting to the Partner Group Leader)
 - e. Set the desired Compressor Run Time Alert (Manager Group Leader will sync this setting to the Partner Group Leader).

LEAD LAG GROUP WIRING DIAGRAM

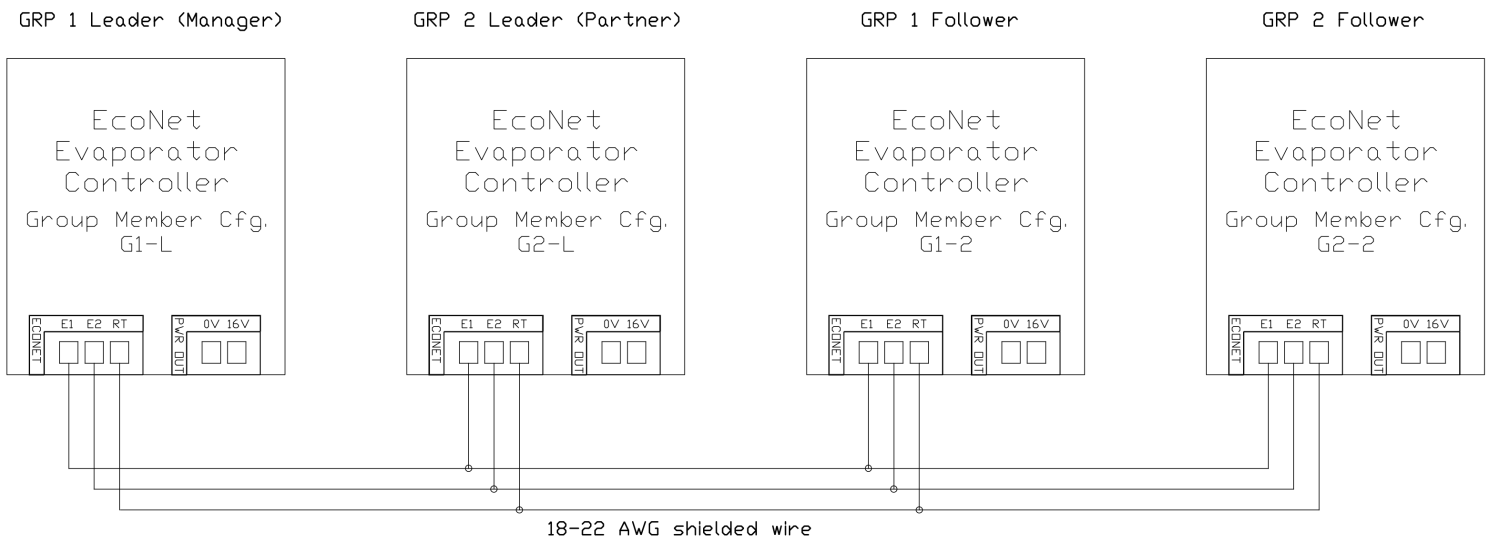

NOTE: Controllers can be wired in any order.

LEAD LAG GROUP INSTALLATION

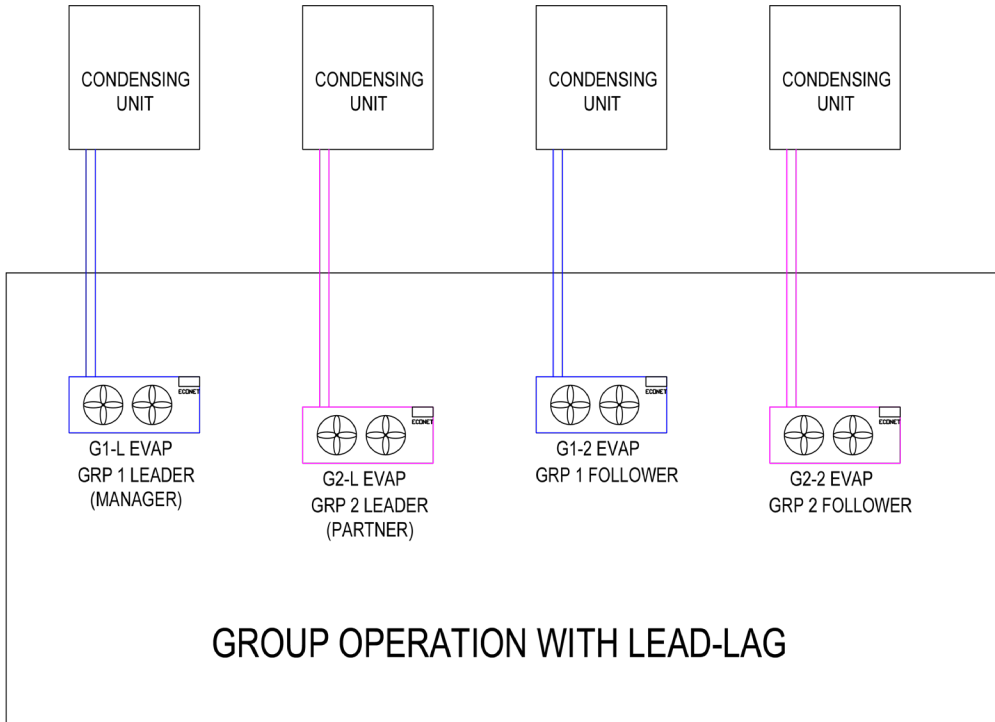

EXAMPLE 1

Group operation: 50% load requirement each compressor

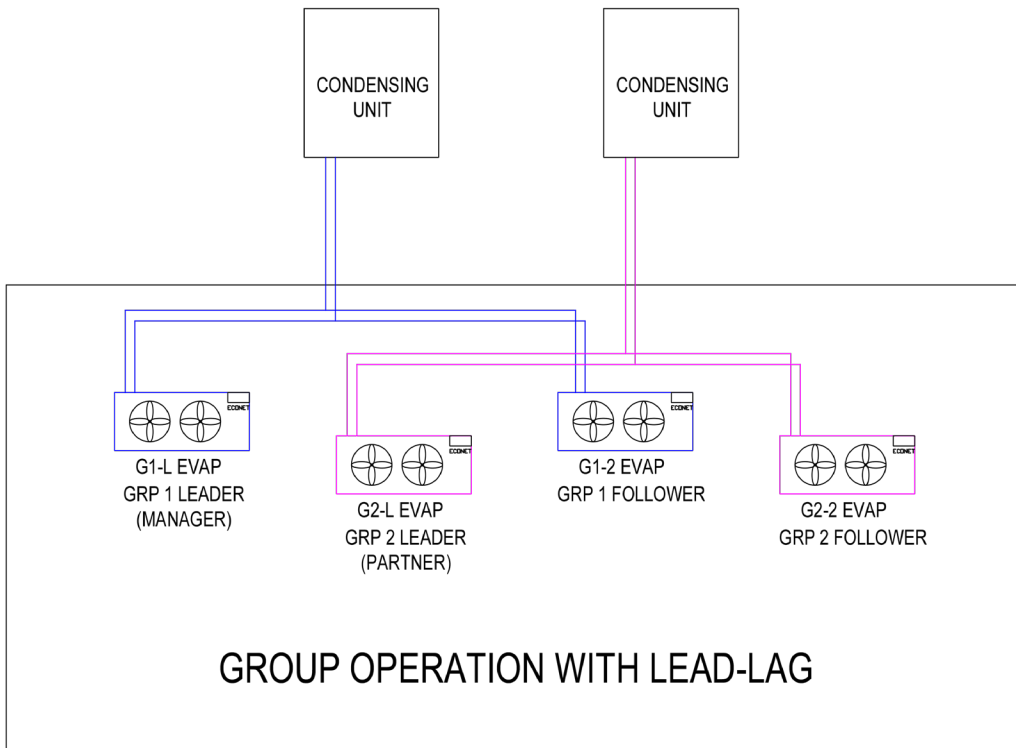

EXAMPLE 2

Lead Lag: 100% load requirement each compressor

LEAD/LAG OPERATION SUMMARY

**Status viewed from Manager controller display*

SYSTEM STATUS	MANAGER	MGR STATUS*	PARTNER	PTNR STATUS*	LEAD LAG CONTROL
Manager Running	Active	Okay	Disabled	Okay	Manager
Partner Running	Disabled	Okay	Active	Okay	Partner
Manager Setpoint Alarm	Active	Satisfy No	Active	Okay	Both
Manager on Setpoint Alarm and starts defrosting	Defrosting	Okay	Disabled	Okay	Neither
Manager on Setpoint Alarm and Partner starts defrosting	Disabled	Okay	Defrosting	Okay	Neither
Partner Setpoint Alarm	Active	Okay	Active	Satisfy No	Both
Partner on Setpoint Alarm and starts defrosting	Disabled	Okay	Defrosting	Okay	Neither
Partner on Setpoint Alarm and Manager starts defrosting	Defrosting	Okay	Disabled	Okay	Neither
Manager & Partner Setpoint Alarm	Active	Satisfy No	Active	Satisfy No	Both
Manager Space Temp Fail Alarm	Disabled	Space Fail	Active	Okay	Partner
Partner Space Temp Fail Alarm	Active	Okay	Disabled	Space Fail	Manager

**Status viewed from Manager controller display*

SYSTEM STATUS	MANAGER	MGR STATUS*	PARTNER	PTNR STATUS*	LEAD LAG CONTROL
Communication lost between Manager and Partner	Active	Okay	Active	Okay	Off
Manager running and set to System Enable = No	Disabled	Can't Run	Active	Okay	Partner
Partner running and set to System Enable = No	Active	Okay	Disabled	Can't Run	Manager
**Manager running gets Door Open Alert	Disabled	Can't Run	Active	Okay	Partner
**Partner running gets Door Open Alert	Active	Okay	Disabled	Can't Run	Manager
Manager running gets Leak Alarm	Disabled	Can't Run	Active	Okay	Partner
Manager running and Partner gets Leak Alarm	Active	Okay	Disabled	Can't Run	Manager
Partner running gets Leak Alarm	Active	Okay	Disabled	Can't Run	Manager
Partner running and Manager gets Leak Alarm	Disabled	Can't Run	Active	Okay	Partner

****NOTE: To use the door switch function with two redundant systems linked for lead-lag operation, each system will need its own door switch with a single pole-single throw (SPST) contact, or one door switch with a double pole-single throw (DPST) contact. The Digital Input #1 on BOTH controllers must be inactive simultaneously for both systems to remain off with "Door Open Alert". Otherwise, when one system is off due to "Door Open Alert", the lead-lag operation will cause the other system to run.**

OPERATIONAL LIMITS

1. Voltage: 115V/230V, 50/60 Hz.
2. Operating Temp range: -40°F to 140°F
3. Operating Humidity range: 0% to 97% RH condensing
4. Defrost Relay #1: 24A at 240VAC
5. Defrost Relay #2: 24A at 240VAC
6. Aux Relay #1: 3A at 120VAC
7. Aux Relay #2: 3A at 120VAC

REPLACEMENT PARTS | NUMBERS

1. EcoNet Control Board (08536930)
2. Space/Drain Temp (08219623)
3. Evap Temp (08219636)
4. Suction Temp (08219637)
5. Suction Pressure 0-150 PSIA (08219621)
6. Suction Pressure 0-700 PSIA for CO2 only (08540186)
7. Wire Harness
 - a. 63" Controller wire harness, Sporlan SER valve only (0821963501)
 - b. 96" Controller wire harness, Sporlan SER valve only (0821963502)
 - c. 126" Controller wire harness, Sporlan SER valve only (0821963503)
 - d. 63" Controller wire harness, multi valve (0853669601)
 - e. 96" Controller wire harness, multi valve (0853669602)
 - f. 126" Controller wire harness, multi valve (0853669603)
8. 10' Harness Extension
 - a. 120" harness extension, SER valve only (08532293)
 - b. 120" harness extension, multi valve (08537410)
9. Sporlan SER Bi-Polar valve adapter (08536760)
10. Sporlan OEV Uni-Polar valve adapter (08537865)
11. Sporlan rubber O-ring for use with OEV Uni-Polar valve (08539677)
12. Carel E2V/E3V/E4V Bi-Polar valve adapter (08536993)
13. Sanhua LPF Uni-Polar valve adapter (08536992)
14. Controller Power Harness (08219638)

For help with replacement parts, e-mail or call our Parts Department at: parts@htpg.com or 1-855-HTPARTS (1-855-487-2787).

ADDENDUM A

Evap Temp Thermistor Resistance Table

Part no. 08219636

FAHRENHEIT	KILO-OHMS	FAHRENHEIT	KILO-OHMS	FAHRENHEIT	KILO-OHMS	FAHRENHEIT	KILO-OHMS
-40	346.62	-4	99.20	32	33.04	69	12.24
-39	335.84	-3	96.44	33	32.22	70	11.96
-38	325.06	-2	93.68	34	31.39	71	11.68
-37	314.28	-1	90.92	35	30.57	72	11.40
-36	303.50	0	88.16	36	29.75	73	11.12
-35	292.71	1	85.41	37	28.92	74	10.84
-34	281.93	2	82.65	38	28.10	75	10.56
-33	271.15	3	79.89	39	27.28	76	10.28
-32	260.37	4	77.13	40	26.46	77	10.00
-31	249.59	5	74.37	41	25.63	78	9.78
-30	242.04	6	72.36	42	25.01	79	9.56
-29	234.49	7	70.35	43	24.39	80	9.35
-28	226.95	8	68.33	44	23.77	81	9.13
-27	219.40	9	66.32	45	23.15	82	8.91
-26	211.85	10	64.31	46	22.52	83	8.69
-25	204.30	11	62.30	47	21.90	84	8.48
-24	196.76	12	60.29	48	21.28	85	8.26
-23	189.21	13	58.27	49	20.66	86	8.04
-22	181.66	14	56.26	50	20.04	87	7.87
-21	176.32	15	54.78	51	19.57	88	7.70
-20	170.98	16	53.30	52	16.29	89	7.53
-19	165.63	17	51.82	53	16.22	90	7.36
-18	160.29	18	50.34	54	16.14	91	7.19
-17	154.95	19	48.86	55	16.07	92	7.02
-16	149.61	20	47.38	56	16.00	93	6.85
-15	144.26	21	45.90	57	15.93	94	6.68
-14	138.92	22	44.42	58	15.86	95	6.51
-13	133.58	23	42.94	59	15.78	96	6.37
-12	129.76	24	41.84	60	15.42	97	6.24
-11	125.94	25	40.74	61	15.06	98	6.10
-10	122.12	26	39.64	62	14.70	99	5.97
-9	118.30	27	38.54	63	14.33	100	5.83
-8	114.48	28	37.44	64	13.97	101	5.70
-7	110.66	29	36.34	65	13.61	102	5.57
-6	106.84	30	35.24	66	13.25	103	5.43
-5	103.02	31	34.14	67	12.88	104	5.30
				68	12.52		

Space/Drain Temp Thermistor Resistance Table

Part no. 08219623

FAHRENHEIT	KILO-OHMS	FAHRENHEIT	KILO-OHMS	FAHRENHEIT	KILO-OHMS	FAHRENHEIT	KILO-OHMS
-40	169.16	-4	48.61	32	16.33	69	6.11
-39	163.89	-3	47.27	33	15.93	70	5.97
-38	158.63	-2	45.92	34	15.52	71	5.83
-37	153.37	-1	44.58	35	15.12	72	5.69
-36	148.11	0	43.23	36	14.71	73	5.55
-35	142.84	1	41.89	37	14.31	74	5.42
-34	137.58	2	40.54	38	13.91	75	5.28
-33	132.32	3	39.19	39	13.50	76	5.14
-32	127.06	4	37.85	40	13.10	77	5.00
-31	121.80	5	36.50	41	12.70	78	4.89
-30	118.13	6	35.52	42	12.39	79	4.78
-29	114.46	7	34.54	43	12.09	80	4.68
-28	110.79	8	33.56	44	11.78	81	4.57
-27	107.12	9	32.58	45	11.48	82	4.46
-26	103.45	10	31.60	46	11.17	83	4.35
-25	99.78	11	30.62	47	10.87	84	4.24
-24	96.11	12	29.64	48	10.56	85	4.14
-23	92.44	13	28.66	49	10.26	86	4.03
-22	88.77	14	27.68	50	9.95	87	3.94
-21	86.16	15	26.96	51	9.72	88	3.86
-20	83.56	16	26.23	52	8.10	89	3.77
-19	80.96	17	25.51	53	8.07	90	3.69
-18	78.35	18	24.79	54	8.03	91	3.61
-17	75.75	19	24.06	55	8.00	92	3.52
-16	73.15	20	23.34	56	7.96	93	3.44
-15	70.54	21	22.61	57	7.93	94	3.35
-14	67.94	22	21.89	58	7.89	95	3.27
-13	65.34	23	21.17	59	7.85	96	3.20
-12	63.48	24	20.63	60	7.68	97	3.13
-11	61.62	25	20.09	61	7.50	98	3.07
-10	59.76	26	19.55	62	7.32	99	3.00
-9	57.90	27	19.02	63	7.14	100	2.93
-8	56.05	28	18.48	64	6.96	101	2.87
-7	54.19	29	17.94	65	6.78	102	2.80
-6	52.33	30	17.40	66	6.60	103	2.73
-5	50.47	31	16.87	67	6.42	104	2.66
				68	6.25		

FAHRENHEIT	KILO-OHMS	FAHRENHEIT	KILO-OHMS	FAHRENHEIT	KILO-OHMS	FAHRENHEIT	KILO-OHMS
-40	336.50	-4	97.07	33	31.84	69	12.21
-39	326.07	-3	94.39	34	31.04	70	11.94
-38	315.63	-2	91.71	35	30.23	71	11.66
-37	305.20	-1	89.02	36	29.42	72	11.38
-36	294.77	0	86.34	37	28.62	73	11.11
-35	284.33	1	83.66	38	27.81	74	10.83
-34	273.90	2	80.98	39	27.00	75	10.55
-33	263.47	3	78.29	40	26.20	76	10.28
-32	253.03	4	75.61	41	25.39	77	10.00
-31	242.60	5	72.93	42	24.78	78	9.78
-30	235.31	6	70.97	43	24.17	79	9.57
-29	228.02	7	69.02	44	23.56	80	9.35
-28	220.73	8	67.06	45	22.95	81	9.14
-27	213.44	9	65.11	46	22.34	82	8.92
-26	206.16	10	63.15	47	21.73	83	8.70
-25	198.87	11	61.20	48	21.12	84	8.49
-24	191.58	12	59.24	49	20.51	85	8.27
-23	184.29	13	57.29	50	19.90	86	8.06
-22	177.00	14	55.33	51	19.43	87	7.89
-21	171.82	15	53.88	52	16.21	88	7.72
-20	166.64	16	52.44	53	16.14	89	7.55
-19	161.47	17	50.99	54	16.07	90	7.38
-18	156.29	18	49.55	55	15.99	91	7.21
-17	151.11	19	48.10	56	15.92	92	7.04
-16	145.93	20	46.66	57	15.85	93	6.87
-15	140.76	21	45.21	58	15.78	94	6.70
-14	135.58	22	43.77	59	15.71	95	6.53
-13	130.40	23	42.32	60	15.35	96	6.40
-12	126.70	24	41.25	61	14.99	97	6.26
-11	122.99	25	40.17	62	14.64	98	6.13
-10	119.29	26	39.10	63	14.28	99	6.00
-9	115.59	27	38.02	64	13.92	100	5.86
-8	111.88	28	36.95	65	13.56	101	5.73
-7	108.18	29	35.87	66	13.21	102	5.59
-6	104.48	30	34.80	67	12.85	103	5.46
-5	100.77	31	33.72	68	12.49	104	5.33
		32	32.65				

Pressure Transducer Voltage Table

Vout (DC)	PSIA	PSIG
0.50	0	-14.7
0.55	2	-12.7
0.61	4	-10.7
0.66	6	-8.7
0.71	8	-6.7
0.77	10	-4.7
0.82	12	-2.7
0.87	14	-0.7
0.93	16	1.3
0.98	18	3.3
1.03	20	5.3
1.09	22	7.3
1.14	24	9.3
1.19	26	11.3
1.25	28	13.3
1.30	30	15.3
1.35	32	17.3
1.41	34	19.3
1.46	36	21.3
1.51	38	23.3
1.57	40	25.3
1.62	42	27.3
1.67	44	29.3
1.73	46	31.3
1.78	48	33.3
1.83	50	35.3
1.89	52	37.3
1.94	54	39.3
1.99	56	41.3
2.05	58	43.3
2.10	60	45.3
2.15	62	47.3
2.21	64	49.3
2.26	66	51.3
2.31	68	53.3
2.37	70	55.3
2.42	72	57.3
2.47	74	59.3

Part no. 08219621

Vout (DC)	PSIA	PSIG
2.53	76	61.3
2.58	78	63.3
2.63	80	65.3
2.69	82	67.3
2.74	84	69.3
2.79	86	71.3
2.85	88	73.3
2.90	90	75.3
2.95	92	77.3
3.01	94	79.3
3.06	96	81.3
3.11	98	83.3
3.17	100	85.3
3.22	102	87.3
3.27	104	89.3
3.33	106	91.3
3.38	108	93.3
3.43	110	95.3
3.49	112	97.3
3.54	114	99.3
3.59	116	101.3
3.65	118	103.3
3.70	120	105.3
3.75	122	107.3
3.81	124	109.3
3.86	126	111.3
3.91	128	113.3
3.97	130	115.3
4.02	132	117.3
4.07	134	119.3
4.13	136	121.3
4.18	138	123.3
4.23	140	125.3
4.29	142	127.3
4.34	144	129.3
4.39	146	131.3
4.45	148	133.3
4.50	150	135.3

ADDENDUM B

CONTROLLER WIRE PINOUT FOR ELECTRONIC EXPANSION VALVES

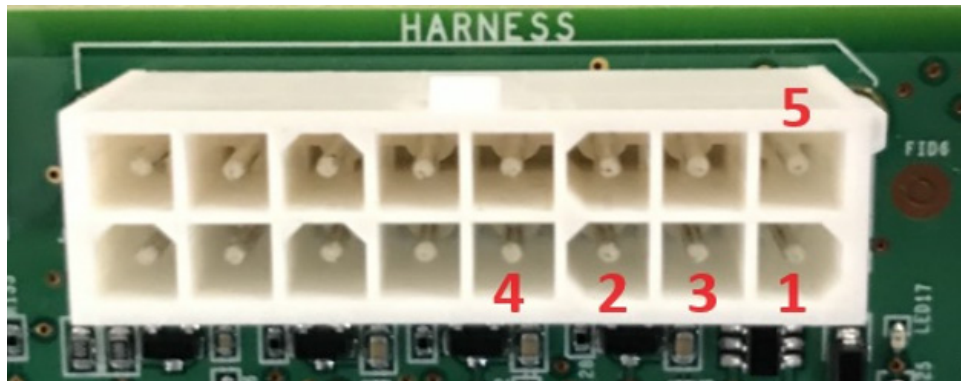

SPORLAN SER (2500 Bi-Polar)

ECONET			SPORLAN CABLE (P/N 805194)
WIRE PIN	OLD HARNESS 082196350X	NEW HARNESS 085366960X	
1	BROWN	ORANGE	GREEN
2	WHITE	YELLOW	WHITE
3	BLUE	RED	RED
4	BLACK	BLACK	BLACK
5	N/A	GRAY	N/A

SPORLAN OEV or SANHUA LPF (500 Uni-Polar)

ECONET		SPORLAN CABLE (P/N 953447)	SANHUA CABLE (PQM24012)
WIRE PIN	NEW HARNESS 085366960X		
1	ORANGE	ORANGE	ORANGE
2	YELLOW	YELLOW	YELLOW
3	RED	RED	RED
4	BLACK	BLACK	BLACK
5	GRAY	GRAY	GRAY

*Legacy EcoNet harness (082196350X) does not have wire for Pin 5, so it cannot be used with Uni-Polar valve.

CAREL E2V/E3V/E4V (480 Bi-Polar)

ECONET			CAREL CABLE (E2VCAB0300)
WIRE PIN	OLD HARNESS 082196350X	NEW HARNESS 085366960X	
1	BROWN	ORANGE	4 - WHITE
2	WHITE	YELLOW	3 - BROWN
3	BLUE	RED	2 - YELLOW
4	BLACK	BLACK	1 - GREEN
5	N/A	GRAY	N/A

SANHUA VPF (2600 Bi-Polar)

ECONET			SANHUA CABLE (P/N 66078)
WIRE PIN	OLD HARNESS 082196350X	NEW HARNESS 085366960X	
1	BROWN	ORANGE	RED
2	WHITE	YELLOW	WHITE
3	BLUE	RED	GREEN
4	BLACK	BLACK	BLACK
5	N/A	GRAY	N/A

ADDENDUM C

BACnet Objects List

EcoNet Software Version: HT-PG-02-00-01-00

NO.	DESCRIPTION	BN OBJECT NAME	BN TYPE	BN ACCESS	EN LIMITS	BN UNITS
1	---	Rheem HTPG	DEVICE			
2	Setpoint	SETPOINT	ANALOG	RW	-40, 60, -10	DEGREES_FAHRENHEIT
3	Defrost Mode	DEFMODE	MULTISTATE	RO	0, 4	---
4	Defrost Mode Group	DEFMODG	BINARY	RO	0, 1	---
5	Space Temp	SPACETMP	ANALOG	RO	-60, 250	DEGREES_FAHRENHEIT
6	Average Space Temp (Group)	SPACEALL	ANALOG	RO	-60, 250	DEGREES_FAHRENHEIT
7	Evap Temp 1	EVAPTEMP	ANALOG	RO	-60, 250	DEGREES_FAHRENHEIT
8	Evap Temp 2	EVTEMP2T	ANALOG	RO	-60, 250	DEGREES_FAHRENHEIT
9	Suction Temp	SUCTIONT	ANALOG	RO	-60, 250	DEGREES_FAHRENHEIT
10	Saturated Suction Temp	SAT_SUCT	ANALOG	RO	-60, 250	DEGREES_FAHRENHEIT
11	Suction Pressure (gauge)	PRESGSUC	ANALOG	RO	0, 400	POUNDS_FORCE_PER_SQUARE_INCH
12	Drain Temp	DRAINTMP	ANALOG	RO	-60, 250	DEGREES_FAHRENHEIT
13	Aux Temp	AUX_TEMP	ANALOG	RO	-60, 250	DEGREES_FAHRENHEIT
14	Fan Speed	PWM_FANC	ANALOG	RO	0, 100	PERCENT
15	Compressor Request	COMP_REQ	BINARY	RO	0, 1	---
16	Lifetime Compressor Cycles	COMPCYCL	ANALOG	RO	0, 4294967295, 0	NO_UNITS
17	Group Member Cfg.	EVPGROUP	MULTISTATE	RO	0, 24, 0	---
18	Instance	INSTANCE	ANALOG	RO	1, 32, 1	NO_UNITS
19	Cooler/Freezer	COOLTYPE	MULTISTATE	RW	0, 1, 1	---
20	Refrigerant	REFRIGER	MULTISTATE	RW	0, 11, 3	---
21	Coil Type	COILTYPE	MULTISTATE	RW	0, 1, 0	---
22	Drain Temp Sensor Y/N?	DRAINCFG	BINARY	RO	0, 1,	---
23	Drain Pan Heater Cut-In Offset	DRAINSET	ANALOG	RW	20, 80, 40	DEGREES_FAHRENHEIT
24	Drain Pan Heater Cut-Out Setpoint	DRAINHYS	ANALOG	RW	1, 20, 5	DEGREES_FAHRENHEIT
25	EXV Stepper Type	EXVSTEPR	MULTISTATE	RW	0, 3, 0	---
26	EXV Superheat Setpoint	EXV_SHSP	ANALOG	RW	4, 20, 6.5	DELTA_DEGREES_FAHRENHEIT
27	Setpoint Control/Hysteresis	SETPHYST	ANALOG	RW	0.5, 20, 2	DELTA_DEGREES_FAHRENHEIT
28	Defrost Type	DEFRTYPE	MULTISTATE	RW	0, 1, 0	---
29	Max Defrost Time	DEFRMAXT	ANALOG	RW	10, 60, 60	MINUTES

ADDENDUM C

BACnet Objects List Continued

NO.	DESCRIPTION	BN OBJECT NAME	BN TYPE(_VALUE - EXPECT DEVICE	BN ACCESS	EN LIMITS	BN UNITS (BACNET_UNITS_)
30	Runtime Until Defrost (Timed)	DEFRCNTM	ANALOG	RW	0, 900, 360	MINUTES
31	Runtime Until Defrost (Adaptive)	DEFRCATM	ANALOG	RW	360, 900, 720	MINUTES
32	Defrost Termination Temp	DEFRTTMP	ANALOG	RW	35, 65, 55	DEGREES_FAHRENHEIT
33	Defrost Relay 1 Control	DEFPOVER	MULTISTATE	RW	0, 1, 0	---
34	Minimum Cooling Run Time	CRQMINON	MULTISTATE	RW	0, 2, 2	---
35	Comp. Run Time Alert	CREQTIME	ANALOG	RW	0, 480, 120	MINUTES
36	Door Switch Config.	DOORCNFG	MULTISTATE	RW	0, 2, 0	---
37	Door Switch Time Delay	DOORATIM	MULTISTATE	RW	0, 6, 0	---
38	Defrost Pump Down Delay	DFEXVTIM	MULTISTATE	RW	0, 5, 0	---
39	Fan Control	FAN_CTRL	MULTISTATE	RO	0, 1, 0	---
40	Aux Relay Config.	AUX_CNFG	MULTISTATE	RO	0, 3, 0	---
41	Cut-Out Setpoint (Pack. Unit Comp. Ctrl.)	CUTOSETP	ANALOG	RW	-5, 60, 0	POUNDS_FORCE_PER_SQUARE_INCH
42	Cut-In Offset (Pack. Unit Comp. Ctrl.)	CUTIOFFS	ANALOG	RW	10, 50, 20	POUNDS_FORCE_PER_SQUARE_INCH
43	Last Defrost Duration	DEFRTIMM	ANALOG	RO	0, 4294967295	MINUTES
44	Runtime Until Next Defrost	DEFRNEXT	ANALOG	RO	0, 4000000000	MINUTES
45	Lifetime Defrost Cycles	DEFRCYCL	ANALOG	RO	0, 65535, 0	NO_UNITS
46	Force a Defrost?	DEFFORCE	BINARY	RW	0, 1	---
47	Digital Input #1	DIGITAL1	BINARY	RO	0, 1	---
48	Digital Input #2	DIGITAL2	BINARY	RO	0, 1	---
49	Digital Input #3	DIGITAL3	BINARY	RO	0, 1	---
50	Defrost Relay 1	DEF1RELY	BINARY	RO	0, 1	---
51	Defrost Relay 2	DEF2RELY	BINARY	RO	0, 1	---
52	Aux Relay 1	AUX1RELY	BINARY	RO	0, 1	---
53	Aux Relay 2	AUX2RELY	BINARY	RO	0, 1	---
54	EXV Current Position %	EXACTUAL	ANALOG	RO	0, 100	PERCENT
55	Calculated Superheat	EXVSUPER	ANALOG	RO	-999, 999	DELTA_DEGREES_FAHRENHEIT
56	Control Superheat Setpoint	EXVCSHSP	ANALOG	RO	0, 25	DELTA_DEGREES_FAHRENHEIT

ADDENDUM C

BACnet Objects List Continued

NO.	DESCRIPTION	BN OBJECT NAME	BN TYPE(_VALUE - EXPECT DEVICE	BN ACCESS	EN LIMITS	BN UNITS (BACNET_UNITS_)
57	Alarm #1	ALARM_01	CHARACTERSTRING	RO	---	---
58	Alarm #2	ALARM_02	CHARACTERSTRING	RO	---	---
59	Alarm History #1	ALARMH01	CHARACTERSTRING	RO	---	---
60	Alarm History #2	ALARMH02	CHARACTERSTRING	RO	---	---
61	Alarm History #3	ALARMH03	CHARACTERSTRING	RO	---	---
62	Alarm History #4	ALARMH04	CHARACTERSTRING	RO	---	---
63	Product Model Number	PRODMODN	CHARACTERSTRING	RO	---	---
64	Product Serial Number	PRODSERN	CHARACTERSTRING	RO	---	---
65	Product Location	PRODLOCA	CHARACTERSTRING	RW	---	---
66	EcoNet Software Version	SW_VERSN	CHARACTERSTRING	RO	---	---
67	Product Description	PRODESC	CHARACTERSTRING	RO	---	---
68	Leak Detector Config.	LEAKCNFG	MULTISTATE	RW	0, 2, 0	---
69	Leak Alarm Recovery Timer Config.	LRECTIMC	ANALOG	RW	5, 600, 300	SECONDS
70	Leak Alarm	LEAKALRM	BINARY	RO	0, 1	---
71	Comp. Minimum ON Timer (Pack. Unit)	AUX2CTMR	ANALOG	RW	10, 120, 60	SECONDS
72	System Enable Y/N	HTPGENAB	BINARY	RW	0, 1, 1	---
73	Superheat Setpoint Offset	EXVOSHSP	ANALOG	RW	0, 10, 3.5	DELTA_DEGREES_FAHRENHEIT
74	Alarm History Clear?	ALHISCLR	BINARY	RW	0, 1	---
75	Unit is in Follower Mode?	FOLLOWER	BINARY	RO	0, 1	---
76	Lead Lag Control Configuration	LEAD_LAG	MULTISTATE	RW	0, 2, 0	---
77	Lead Lag Partner Instance	LLMPINST	MULTISTATE	RW	0, 36, 0	---
78	Lead Lag Comp. Run Time Limit (HOURS)	LLCLIMIT	MULTISTATE	RW	0, 23, 6	---
79	Lead Lag Control Status	LLAGCTRL	MULTISTATE	RO	0, 4	---
80	Lead Lag Run Status	LDLGSTAT	MULTISTATE	RO	0, 4	---
81	Lead Lag Run Status -Partner	LDLGSTAP	MULTISTATE	RO	0, 4	---

ADDENDUM C

BACnet Objects List Continued

NO.	DESCRIPTION	BN OBJECT NAME	BN TYPE(_VALUE - EXPECT DEVICE)	BN ACCESS	EN LIMITS	BN UNITS (BACNET_UNITS_)
82	Lead Lag Disable Command	LLDISABL	BINARY	RO	0, 1	---
83	Comp. Run Time Until Lead Lag Switch	LLSWNEXT	ANALOG	RO	0, 10000000	HOURS
84	Fan Delay Temp	EVLOTRIP	ANALOG	RW	25, 70, 35	DEGREES_FAHRENHEIT
85	Defrost Drain Time	DEFDTIME	ANALOG	RW	0, 600, 300	SECONDS
86	EXV Last Position Minimum	ELASTMIN	ANALOG	RW	15, 100, 35	PERCENT
87	EXV Last Position Maximum	ELASTMAX	ANALOG	RW	65, 100, 65	PERCENT
88	EXV Start Delay	EXVDELAY	ANALOG	RW	0, 255, 60	SECONDS



ENGINEERED FOR COOL.™

[HTPG.com](https://www.htpg.com)

©2023 Heat Transfer Products Group

Published September 2024

HTPG1024_EN_IOM

