

**MEDIUM**

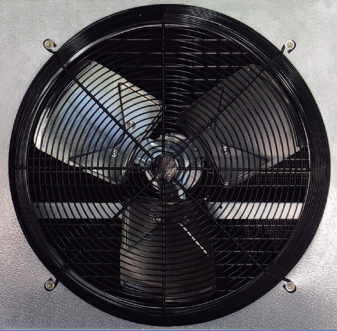

## MEDIUM PROFILE UNIT COOLER

AIR, ELECTRIC & HOT GAS MODELS  
11,000 TO 76,900 BTUH

MEDIUM TO LARGE WALK-INS  
COOLER AND FREEZER APPLICATIONS

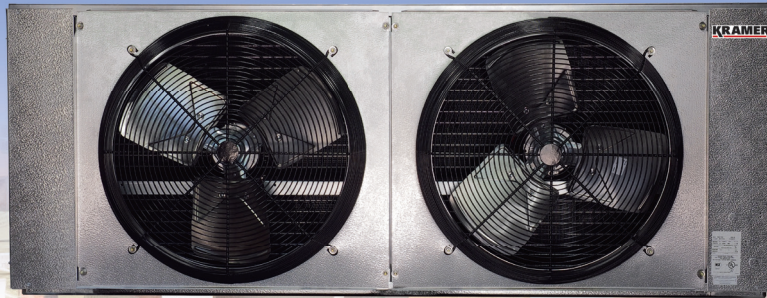

# Medium Profile Unit Cooler

## Features

Kramer's Medium Profile Unit Coolers are the perfect evaporator solution for medium to large walk-in coolers and freezers. Designed with efficiency, performance and service in mind, the Medium Profile line truly stands out from the competition. The unit coolers were engineered to meet the Department of Energy's new AWEF\* performance regulations and all feature energy-efficient rail-mount Dual Speed EC Motors. For maximum performance, all units are circuited for multiple refrigerants and feature optimized circuit patterns, enhanced surface coil tubing, and new high efficiency fan and venturi designs. The Medium Profile product line has several serviceability features including rail-mount motors, easily removable fan guards and modular fan panels, face mount defrost heaters, hinged drain pans, and shipping pallets designed to facilitate quicker installation.

### SIZES

There are a wide array of sizes available with capacities ranging from 11,000 to 76,900 BTUH at a 10° TD. Models are available with air flow spanning a range of 2,090 to 9,580 CFM.

### HOUSING

Each unit is constructed with a rust-free, heavy gauge, textured, aluminum housing which is light weight yet extremely durable. Models feature hinged one-piece drain pans to allow for convenient servicing and maintenance. Hanger holes are provided on all units for fast installation.

### COIL

Seamless copper tubes are staggered and mechanically expanded into corrugated aluminum fins to assure maximum heat transfer. Die formed fin collars are provided for accurate fin spacing. Top panel is fastened directly to the tube sheets of the coil to provide high structural strength. Electric Defrost and Hot Gas Defrost Models are available in both 6 FPI and 4 FPI.

### MOTORS

All models feature highly efficient Dual Speed Electronically Commutated (EC) motors which are compliant with California Title 24 regulations<sup>1</sup>.

### FANS & FAN GUARDS

Powerful heavy-duty aluminum fans are individually balanced to provide vibration free operation. Standard heavy-gauge wire fan guards are UL/cUL-approved epoxy coated for corrosion resistance. Air throw for Medium Profile Unit Coolers is 75 ft.

### REFRIGERANTS

Medium Profile Unit Coolers are optimized for multiple refrigerants including R404A, R407A, R448A, R449A and R744 DX (CO<sub>2</sub>). Please specify system refrigerant requirements when ordering. A separate compartment is provided for all refrigerant connections which allows ample room for internal mounting of expansion valves.

### ELECTRICAL

Available in 115V/1<sup>2</sup>, 208/230V/1<sup>2</sup>, 208-230V/3<sup>2</sup>, 460V/1 or 460/3<sup>2</sup>. A large compartment is supplied for all electrical components and is easily accessible by removing the end panel. All models are UL and cUL listed.

### AIR DEFROST

Air Defrost models (KM6A) are designed for use in coolers at +35°F and warmer.

### ELECTRIC DEFROST

Electric Defrost models (KM6E or KM4E) are designed for use in coolers and freezers between 35°F to -30°F. Electric Defrost 4 FPI models (RM4E) are designed for use in freezers between 32°F and -30°F. Defrost heaters are mounted on the air intake side of the unit for optimal performance and easy maintenance. Heaters are installed inside the drain pan for fast, reliable drainage. Fixed defrost termination, fan delay and heater safety controls are factory mounted for optimum performance of each control function.

### HOT GAS DEFROST

There are two types of Hot Gas Defrost models available: 3-pipe Hot Gas models (KM6H or KM4H) and 2-pipe Hot Gas Reverse Cycle units (KM6G or KM4G). Hot Gas Defrost models are designed for use in coolers and freezers between 35°F and -30°F. Hot Gas Defrost 4 FPI models (KM4H or KM4G) are designed for use in freezers between 32°F and -30°F. All units include fixed defrost termination and fan delay controls which are factory mounted for optimum performance of each control function. Hot Gas Defrost models feature electric drain pan heaters making it possible to open the hinged drain pan for easy cleaning and servicing. Refer to the current Kramer Technical Bulletin for piping.

## Optional Features

- EcoNet<sup>®</sup> Enabled Controller<sup>3</sup> (factory-installed)
- EcoNet<sup>®</sup> Command Center (loose)
- Thermostat - Mechanical or Electric (mounted or loose)
- Thermostatic Expansion Valve (mounted or loose)
- Adjustable Defrost Termination
- Electronic Expansion Valve (mounted or loose)
- Liquid Line Solenoid Valve (mounted or loose)
- Insulated Drain Pan
- Painted Cabinet (White or Black)
- Stainless Steel Cabinet
- Coated Coil (Epoxy Coated, Bronz-Glow, or Electrofin<sup>®</sup>)
- Suction/Liquid Heat Exchanger (loose)

### NOTES

- \* AWEF (Annual Walk-in Energy Factor)
1. Single Compressor system without variable capacity.
  2. Some limitations apply. For specific electrical offering, consult electrical data tables in this brochure.
  3. EcoNet Control Package includes: EEV; suction pressure transducer; suction, entering air coil temp. thermistors; local on-board two-row backlit LCD display and push-button adjustments. (Controller replaces TXV, liquid line solenoid valve, room thermostat, defrost termination and fan delay, and time clock.)

## Highlighted Features and Options



### FANS AND HOUSING

- 24" heavy duty aluminum fans are balanced for vibration-free operation
- High efficiency deep draw venturi provides optimal air flow
- Removeable end panels
- NSF approved



### COILS AND DEFROST HEATERS

- Available in 4 or 6 fins per inch (FPI)
- Electric defrost heaters are mounted on the air intake coil face to provide easy service access
- The drain pan heater is affixed to the drain pan and is easily accessed for service or cleaning



### ECONET ENABLED UNIT COOLERS (Optional)

- Developed in conjunction with Rheem Manufacturing specifically for walk-in coolers and freezers — it builds on the reliability and efficiency of Rheem's EcoNet technology
- Saves energy in refrigeration systems through precise superheat and space temperature control, fan cycling, and controlling how often the system goes into defrost based on compressor runtime
- Eliminates unnecessary defrosts
  - Maximizes energy efficiency with less compressor runtime
  - Reduces fan speed to 50% during off cycle for energy savings
- Can be used with a condensing unit in single and multiple evaporator installations as a group
- Optional **EcoNet Command Center** with intuitive graphical interface controls up to 32 devices (including the Command Center) through one display, provides continuous communication between system components, and the remote mount display allows for EcoNet Enabled Unit Coolers to be programmed, monitored and troubleshot outside of the space being cooled

### ELECTRICAL AND PIPING

- End panels slide out for easy service from the front or sides of the unit
- Ample room in electrical and piping compartments for easy access

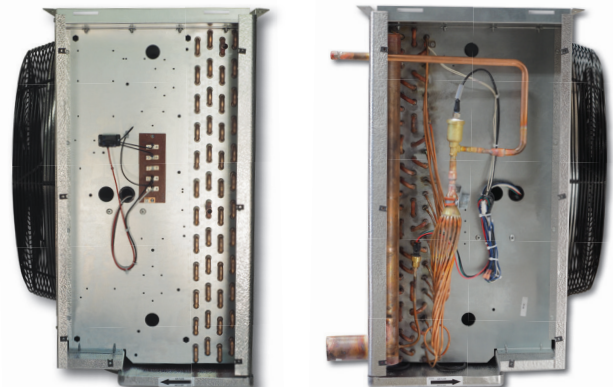

**MODEL NUMBER NOMENCLATURE****CONFIGURABLE BASE MODEL**

<b>K</b>	<b>M</b>	<b>6</b>	<b>E</b>	<b>153</b>	<b>D</b>	<b>D</b>	<b>A</b>
<b>Brand</b>	<b>Style</b>	<b>Fins Per Inch (FPI)</b>	<b>Defrost Type</b>	<b>BTUH in Hundreds</b>	<b>Unit Voltage<sup>1</sup></b>	<b>Motor Type</b>	<b>Vintage</b>
K = Kramer	M = Medium Profile	4 6	A = Air E = Electric H = Hot Gas 3-Pipe G = Hot Gas Reverse T = Thermobank		A = 115/1/60 D = 208-230/1/60 E = 208-230/3/60 F = 460/1/60 G = 460/3/60	D = Dual Speed EC	

Note:

1. 50 Hz available. Contact Factory for additional information.

**EVAPORATOR APPLICATION RATINGS**

Multiple conditions combine to determine the application capacity of an evaporator. Walk-in space temperature, relative humidity, saturated suction temperature difference, and outdoor ambient temperature. All of the factors are considered when calculating an evaporator application rating. These ratings are considerably higher than the net capacity value used for DOE ratings (AWEF).

The AWEF of an evaporator is calculated using the dry coil capacity and the daily evaporator power consumption. Power consumption included fan and defrost power. Evaporator net capacity reported to the DOE database is dry coil capacity less the full power fan watts. DOE test conditions are at 10°F evaporator/SST temperature difference and less than 50% relative humidity and 96°F liquid temperature. These conditions create a uniform test method, but should not be used for equipment selection. The equipment selected would be too large for the application.

Kramer's published application ratings are a guideline for proper equipment selection. They account for true operating conditions experienced by equipment.

Application Rating and Electrical Data - Air Defrost Models - 6 FPI

Model Number	BTUH Capacity @ 25°F S.T & 10°F TD		CFM	No. of Fans	Total Fan Motor AMPS			MCA	MOPD
	R404A/ R744 DX (CO <sub>2</sub> )	R407A/ R448A/ R449A <sup>^</sup>			Dual Speed EC <sup>†</sup> Motors				
					Motor Voltage				
					115V/1	208- 230V/1	460V/1		
KM6A182*DA KM6A220*DA	18,200 22,000	21,100 25,800	3,190 2,950	1	3.2	1.9	1.2	15.0	20
KM6A276*DA KM6A370*DA KM6A442*DA	27,600 37,000 44,200	32,300 43,100 51,900	6,950 6,380 5,900	2	6.4	3.8	2.4	15.0	20
KM6A549*DA KM6A658*DA	54,900 65,800	64,200 76,900	9,580 8,860	3	9.6	5.7	3.6	15.0	20

\* Asterisk represents a variable character based on voltage ordered. See page 4 for nomenclature.

<sup>^</sup> R407A, R448A and R449A are rated at dew point temperature. Use R407A capacity ratings for R407C and R407E.

<sup>†</sup> Dual Speed EC motors are compliant with California Title 24 regulations.

Models were designed in anticipation of the July 2020 Department of Energy Annual Walk-in Energy Factor (AWEF) regulations for evaporators for Walk-in Coolers and Freezers in boxes less than 3,000 sq. ft. See page 16 for AWEF compliance ratings.

FAN GUARDS EASILY REMOVABLE FOR QUICK ACCESS TO FAN BLADES AND RAIL-MOUNTED MOTORS

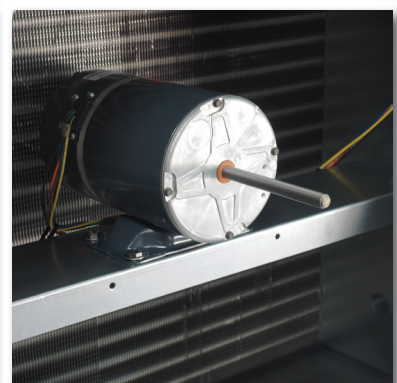
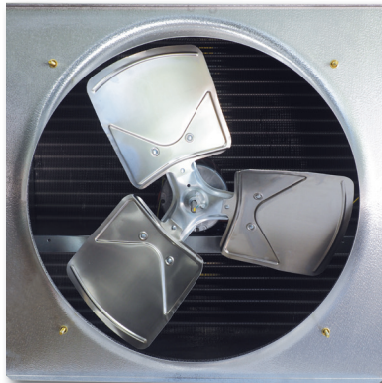
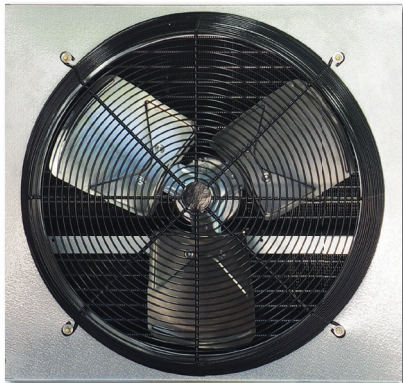

# Medium Profile Unit Cooler

## Application Rating and Electrical Data - Electric Defrost Models

Model Number	BTUH Capacity @ -20°F S.T. & 10°F TD <sup>1</sup>		CFM	No. of Fans	Total Fan Motor AMPS	
	R404A/ R-744 DX (CO <sub>2</sub> )	R407A/ R448A/ R449A <sup>^</sup>			Dual Speed EC Motors <sup>†</sup>	
					Motor Voltage	
					208-230V/1	460V/1

### 6 FPI

KM6E153*DA	15,300	17,400	2,250	1	1.9	1.2
KM6E184*DA	18,400	21,100	2,090			
KM6E311*DA	31,100	35,700	4,500	2	3.8	2.4
KM6E374*DA	37,400	42,900	4,180			
KM6E469*DA	46,900	53,600	6,750	3	5.7	3.6
KM6E564*DA	56,400	64,300	6,270			

### 4 FPI

KM4E110*DA	11,000	12,400	2,350	1	1.9	1.2
KM4E143*DA	14,300	16,200	2,210			
KM4E232*DA	23,200	26,100	4,690	2	3.8	2.4
KM4E288*DA	28,800	32,700	4,420			
KM4E336*DA	33,600	38,300	7,040	3	5.7	3.6
KM4E419*DA	41,900	47,600	6,640			

Model Number	208-230V/1				Heater Amps	Heater Watts
	MCA		MOPD			
	Base Model	EcoNet Enabled <sup>2</sup>	Base Model	EcoNet Enabled <sup>2</sup>	208-230V/1	

### 6 FPI

KM6E153DDA	15.0	20.5	20	25	19.5	4,480
KM6E184DDA						
KM6E311DDA	15.0	40.5	20	45	38.5	8,860
KM6E374DDA						

### 4 FPI

KM4E110DDA	15.0	20.5	20	25	19.5	4,480
KM4E143DDA						
KM4E232DDA	15.0	40.5	20	45	38.5	8,860
KM4E288DDA						

Notes:

1.

Capacity Correction for Electric Defrost Evaporators						
S.S.T. (Dew)	20°F	0°F	-10°F	-20°F	-30°F	-40°F
Multiply Capacity by:	1.15	1.075	1.0375	1	0.9625	0.925

2. EcoNet Enabled Units are not powered by Condensing Unit so Defrost Heaters are incorporated into shown MCA/MOPD.

\* Each asterisk represents a variable character based on voltage ordered. See page 4 for nomenclature.

<sup>^</sup> R407A, R448A and R449A are rated at dew point temperature. Use R407A capacity ratings for R407C and R407F.

<sup>†</sup> Dual Speed EC motors are compliant with California Title 24 regulations.

Models were designed in anticipation of the July 2020 Department of Energy Annual Walk-in Energy Factor (AWEF) regulations for evaporators for Walk-in Coolers and Freezers in boxes less than 3,000 sq. ft. See page 16 for AWEF compliance ratings.

Application Rating and Electrical Data - Electric Defrost Models continued

Model Number	208-230V/3				Heater Amps	Heater Watts
	MCA		MOPD		208-230V/3	
	Base Model	EcoNet Enabled <sup>1</sup>	Base Model	EcoNet Enabled <sup>1</sup>		

6 FPI

KM6E153EDA KM6E184EDA	15.0	15.0	20	25	11.2	4,480
KM6E311EDA KM6E374EDA	15.0	23.2	20	25	22.2	8,860
KM6E469EDA KM6E564EDA	15.0	35.5	20	40	33.5	13,340

4 FPI

KM4E110EDA KM4E143EDA	15.0	15.0	20	25	11.2	4,480
KM4E232EDA KM4E288EDA	15.0	23.2	20	25	22.2	8,860
KM4E336EDA KM4E419EDA	15.0	35.5	20	40	33.5	13,340

Model Number	460V/1				Heater Amps	Heater Watts
	MCA		MOPD		460V/1	
	Base Model	EcoNet Enabled <sup>1</sup>	Base Model	EcoNet Enabled <sup>1</sup>		

6 FPI

KM6E153FDA KM6E184FDA	15.0	15.0	20	25	9.7	4,480
KM6E311FDA KM6E374FDA	15.0	20.3	20	25	19.3	8,860
KM6E469FDA KM6E564FDA	15.0	30.0	20	35	29.0	13,340

4 FPI

KM4E110FDA KM4E143FDA	15.0	15.0	20	25	9.7	4,480
KM4E232FDA KM4E288FDA	15.0	20.3	20	25	19.3	8,860
KM4E336FDA KM4E419FDA	15.0	30.0	20	35	29.0	13,340

Notes:

1. EcoNet Enabled Units are not powered by Condensing Unit so Defrost Heaters are incorporated into shown MCA/MOPD.

^ R407A, R448A and R449A are rated at dew point temperature. Use R407A capacity ratings for R407C and R407F.

† Dual Speed EC motors are compliant with California Title 24 regulations.

Models were designed in anticipation of the July 2020 Department of Energy Annual Walk-in Energy Factor (AWEF) regulations for evaporators for Walk-in Coolers and Freezers in boxes less than 3,000 sq. ft. See page 16 for AWEF compliance ratings.

## Application Rating and Electrical Data - Electric Defrost Models continued

Model Number	460V/3				Heater Amps	Heater Watts
	MCA		MOPD			
	Base Model	EcoNet Enabled <sup>1</sup>	Base Model	EcoNet Enabled <sup>1</sup>	460V/3	

## 6 FPI

KM6E153GDA KM6E184GDA	15.0	15.0	20	20	5.6	4,480
KM6E311GDA KM6E374GDA	15.0	15.0	20	20	11.1	8,860
KM6E469GDA KM6E564GDA	15.0	17.7	20	20	16.7	13,340

## 4 FPI

KM4E110GDA KM4E143GDA	15.0	15.0	20	20	5.6	4,480
KM4E232GDA KM4E288GDA	15.0	15.0	20	20	11.1	8,860
KM4E336GDA KM4E419GDA	15.0	17.7	20	20	16.7	13,340

## Notes:

1. EcoNet Enabled Units are not powered by Condensing Unit so Defrost Heaters are incorporated into shown MCA/ MOPD.

^ R407A, R448A and R449A are rated at dew point temperature. Use R407A capacity ratings for R407C and R407F.

† Dual Speed EC motors are compliant with California Title 24 regulations.

Models were designed in anticipation of the July 2020 Department of Energy Annual Walk-in Energy Factor (AWEF) regulations for evaporators for Walk-in Coolers and Freezers in boxes less than 3,000 sq. ft. See page 16 for AWEF compliance ratings.



**SUPPORTS ARE BOLTED TO PALLET AND UNIT COOLER  
FOR PRODUCT SAFETY AND QUICKER INSTALLATION**



## Application Rating and Electrical Data - Hot Gas 3-Pipe Defrost Models

Hot Gas 3-Pipe Model Number <sup>+</sup>	BTUH Capacity @ -20°F S.T. & 10°F TD <sup>1</sup>		CFM	No. of Fans	Total Fan Motor AMPS		MCA	MOPD
	R404A/ R-744 DX (CO <sub>2</sub> )	R407A/ R448A/ R449A <sup>^</sup>			Dual Speed EC Motors <sup>†</sup>			
					Motor Voltage			
					208-230V/1	460V/1		

### 6 FPI

KM6H153*DA	15,300	17,400	2,250	1	1.9	1.2	15.0	20
KM6H184*DA	18,400	21,100	2,090					
KM6H311*DA	31,100	35,700	4,500	2	3.8	2.4	15.0	20
KM6H374*DA	37,400	42,900	4,180					
KM6H469*DA	46,900	53,600	6,750	3	5.7	3.6	15.0	20
KM6H564*DA	56,400	64,300	6,270					

### 4 FPI

KM4H110*DA	11,000	12,400	2,350	1	1.9	1.2	15.0	20
KM4H143*DA	14,300	16,200	2,210					
KM4H232*DA	23,200	26,100	4,690	2	3.8	2.4	15.0	20
KM4H288*DA	28,800	32,700	4,420					
KM4H336*DA	33,600	38,300	7,040	3	5.7	3.6	15.0	20
KM4H419*DA	41,900	47,600	6,640					

Hot Gas 3-Pipe Model Number <sup>+</sup>	Drain Pan Heater Amps		Drain Pan Heater Watts
	208-230V/1	460V/1	

### 6 FPI

KM6H153*DA	6.4	3.2	1,480
KM6H184*DA			
KM6H311*DA	12.9	6.4	2,960
KM6H374*DA			
KM6H469*DA	19.3	9.7	4,440
KM6H564*DA			

### 4 FPI

KM4H110*DA	6.4	3.2	1,480
KM4H143*DA			
KM4H232*DA	12.9	6.4	2,960
KM4H288*DA			
KM4H336*DA	19.3	9.7	4,440
KM4H419*DA			

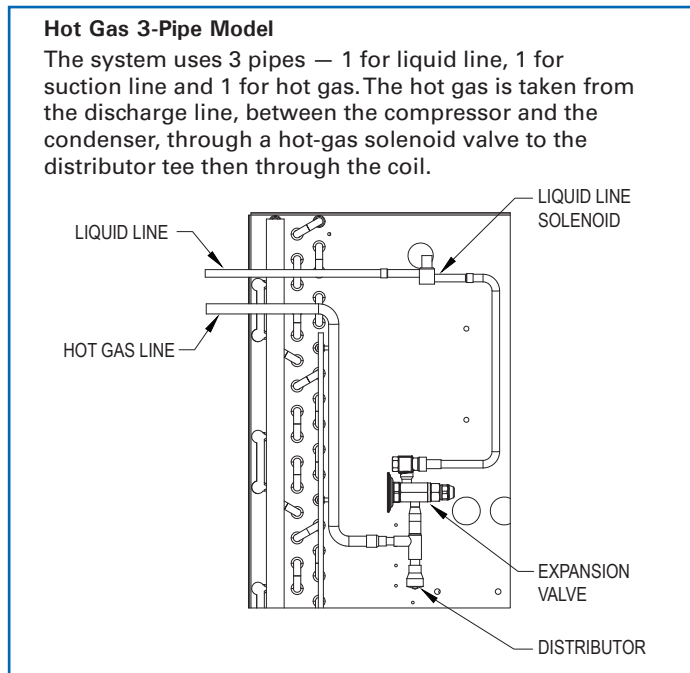

Notes:

1.

Capacity Correction for Hot Gas Defrost Evaporators						
S.S.T. (Dew)	20°F	0°F	-10°F	-20°F	-30°F	-40°F
Multiply Capacity by:	1.15	1.075	1.0375	1	0.9625	0.925

\* Each asterisk represents a variable character based on voltage ordered. See page 4 for nomenclature.

+ Hot Gas models include an electric drain pan. † Dual Speed EC motors are compliant with California Title 24 regulations.

<sup>^</sup> R407A, R448A and R449A are rated at dew point temperature. Use R407A capacity ratings for R407C and R407F. Models were designed in anticipation of the July 2020 Department of Energy Annual Walk-in Energy Factor (AWEF) regulations for evaporators for Walk-in Coolers and Freezers in boxes less than 3,000 sq. ft. See page 16 for AWEF compliance ratings.

# Medium Profile Unit Cooler

## Application Rating and Electrical Data - Hot Gas Reverse Cycle Defrost Models

Hot Gas Reverse Cycle Model Number <sup>+</sup>	BTUH Capacity @ -20°F S.T. & 10°F TD <sup>1</sup>		CFM	No. of Fans	Total Fan Motor AMPS		MCA	MOPD
	R404A/ R-744 DX (CO <sub>2</sub> )	R407A/ R448A/ R449A <sup>^</sup>			Dual Speed EC Motors <sup>†</sup>			
					Motor Voltage			
					208-230V/1	460V/1		

### 6 FPI

KM6G153*DA	15,300	17,400	2,250	1	1.9	1.2	15.0	20
KM6G184*DA	18,400	21,100	2,090					
KM6G311*DA	31,100	35,700	4,500	2	3.8	2.4	15.0	20
KM6G374*DA	37,400	42,900	4,180					
KM6G469*DA	46,900	53,600	6,750	3	5.7	3.6	15.0	20
KM6G564*DA	56,400	64,300	6,270					

### 4 FPI

KM4G110*DA	11,000	12,400	2,350	1	1.9	1.2	15.0	20
KM4G143*DA	14,300	16,200	2,210					
KM4G232*DA	23,200	26,100	4,690	2	3.8	2.4	15.0	20
KM4G288*DA	28,800	32,700	4,420					
KM4G336*DA	33,600	38,300	7,040	3	5.7	3.6	15.0	20
KM4G419*DA	41,900	47,600	6,640					

Hot Gas Reverse Cycle Model Number <sup>+</sup>	Drain Pan Heater Amps		Drain Pan Heater Watts
	208-230V/1	460V/1	

### 6 FPI

KM6G153*DA	6.4	3.2	1,480
KM6G184*DA			
KM6G311*DA	12.9	6.4	2,960
KM6G374*DA			
KM6G469*DA	19.3	9.7	4,440
KM6G564*DA			

### 4 FPI

KM4G110*DA	6.4	3.2	1,480
KM4G143*DA			
KM4G232*DA	12.9	6.4	2,960
KM4G288*DA			
KM4G336*DA	19.3	9.7	4,440
KM4G419*DA			

### Hot Gas Reverse Cycle 2-Pipe Model

A changeover valve is located in the discharge suction line of the compressor, so that when defrost is required, the valve changes over from the normal refrigeration flow so that the discharged gas flows into the suction connection and bypasses TX valve.

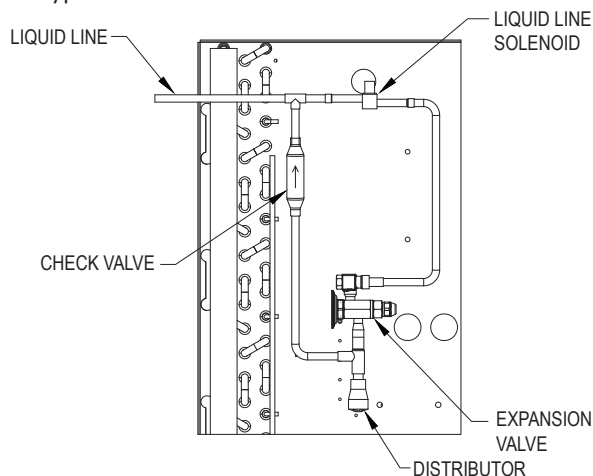

Notes:

Capacity Correction for Hot Gas Defrost Evaporators						
S.S.T. (Dew)	20°F	0°F	-10°F	-20°F	-30°F	-40°F
Multiply Capacity by:	1.15	1.075	1.0375	1	0.9625	0.925

\* Each asterisk represents a variable character based on voltage ordered. See page 4 for nomenclature.

+ Hot Gas models include an electric drain pan. † Dual Speed EC motors are compliant with California Title 24 regulations.

^ R407A, R448A and R449A are rated at dew point temperature. Use R407A capacity ratings for R407C and R407F.

Models were designed in anticipation of the July 2020 Department of Energy Annual Walk-in Energy Factor (AWEF) regulations for evaporators for Walk-in Coolers and Freezers in boxes less than 3,000 sq. ft. See page 16 for AWEF compliance ratings.

Distributor Nozzle and Expansion Valves - Air Defrost Models

Model Number	Part Numbers						No. of Circuits
	Nozzle @ Liq. Temp.		TXV <sup>^</sup> @ Liq. Temp.		EEV @ Liq. Temp.		
	50°F	105°F	50°F	105°F	50°F	105°F	

R404A

6 FPI	KM6A182*DA	L-3/4	L-2	SBFSE-B-C	SBFSE-B-C	SER-B	SER-B	4
	KM6A220*DA	L-3/4	L-2-1/2	SBFSE-B-C	SBFSE-B-C	SER-B	SER-B	6
	KM6A276*DA	L-1	L-3	SBFSE-B-C	SBFSE-C-C	SER-B	SER-C	8
	KM6A370*DA	L-1-1/2	L-4	SBFSE-C-C	SBFSE-C-C	SER-C	SER-C	9
	KM6A442*DA	G-1-1/2	G-5	EBSSE-6-C	EBSSE-6-C	SER-C	SER-C	12
	KM6A549*DA	G-2	G-6	EBSSE-6-C	EBSSE-6-C	SER-C	SER-C	12
KM6A658*DA	G-2-1/2	G-8	EBSSE-6-C	EBSSE-6-C	SER-C	SER-D	16	

R407A/ R407C<sup>†</sup>

6 FPI	KM6A182*DA	L-3/4	L-2	SBFDE-B-C	SBFDE-B-C	SER-B	SER-B	4
	KM6A220*DA	L-3/4	L-2-1/2	SBFDE-B-C	SBFDE-B-C	SER-B	SER-B	6
	KM6A276*DA	L-1	L-3	SBFDE-B-C	SBFDE-B-C	SER-B	SER-C	8
	KM6A370*DA	L-1-1/2	L-4	SBFDE-C-C	SBFDE-C-C	SER-C	SER-C	9
	KM6A442*DA	G-1-1/2	G-5	SBFDE-C-C	SBFDE-C-C	SER-C	SER-C	12
	KM6A549*DA	G-2	G-6	EBSDE-7-C	SBFDE-C-C	SER-C	SER-C	12
KM6A658*DA	G-2-1/2	G-8	EBSDE-7-C	EBSDE-7-C	SER-C	SER-D	16	

R448A/ R449A<sup>†</sup>

6 FPI	KM6A182*DA	L-3/4	L-2	SBFDE-B-C	SBFDE-B-C	SER-B	SER-B	4
	KM6A220*DA	L-3/4	L-2-1/2	SBFDE-B-C	SBFDE-B-C	SER-B	SER-B	6
	KM6A276*DA	L-1	L-3	SBFDE-C-C	SBFDE-C-C	SER-B	SER-C	8
	KM6A370*DA	L-1-1/2	L-4	SBFDE-C-C	SBFDE-C-C	SER-C	SER-C	9
	KM6A442*DA	G-1-1/2	G-5	SBFDE-C-C	EBSDE-7-C	SER-C	SER-C	12
	KM6A549*DA	G-2	G-6	EBSDE-7-C	EBSDE-7-C	SER-C	SER-C	12
KM6A658*DA	G-2-1/2	G-8	EBSDE-7-C	EBSDE-7-C	SER-C	SER-D	16	

Note: The distributor lines are 3/16" tube & 21" long.

\* Each asterisk represents a variable character based on voltage ordered. See page 4 for nomenclature.

<sup>^</sup> TXV selections are based on +25°F suction temp., 8°F to 12°F evaporator TD. Contact factory for operating conditions outside of this range.

<sup>†</sup> SBFDE expansion valves are compatible with R407A, R448A and R449A/B. For other valves, follow manufacturers selection guidelines.

Base models (no factory-mounted components) include nozzles sized for 100°F liquid shipped loose.

Typical Applications:



Small to Medium Warehouses



Industrial and Pharmaceuticals



Walk-in Coolers and Freezers

# Medium Profile Unit Cooler

## Distributor Nozzle and Expansion Valves - Electric Defrost Models

Model Number	Part Numbers						No. of Circuits
	Nozzle @ Liq. Temp.		TXV <sup>^</sup> @ Liq. Temp.		EEV @ Liq. Temp.		
	50°F	105°F	50°F	105°F	50°F	105°F	

### R404A

6 FPI	KM6E153*DA	L-1-1/2	L-2-1/2	SBFSE-B-Z	SBFSE-B-Z	SER-B	SER-B	6
	KM6E184*DA	L-1-1/2	L-3	SBFSE-B-Z	SBFSE-C-Z	SER-B	SER-B	8
	KM6E311*DA	G-2-1/2	G-5	SBFSE-C-Z	EBSSE-6-Z	SER-B	SER-C	12
	KM6E374*DA	G-3	G-6	EBSSE-6-Z	EBSSE-6-Z	SER-C	SER-C	16
	KM6E469*DA	G-4	G-10	EBSSE-6-Z	EBSSE-7-1/2-Z	SER-C	SER-C	18
	KM6E564*DA	G-5	G-12	EBSSE-7-1/2-Z	EBSSE-10-Z	SER-C	SER-C	24
4 FPI	KM4E110*DA	L-1	L-2	SBFSE-A-Z	SBFSE-A-Z	SER-A	SER-A	4
	KM4E143*DA	L-1-1/2	L-2-1/2	SBFSE-A-Z	SBFSE-B-Z	SER-A	SER-B	6
	KM4E232*DA	L-2	L-4	SBFSE-B-Z	SBFSE-C-Z	SER-B	SER-B	9
	KM4E288*DA	G-2-1/2	G-5	SBFSE-C-Z	EBSSE-6-Z	SER-B	SER-C	12
	KM4E336*DA	G-3	G-6	SBFSE-C-Z	EBSSE-6-Z	SER-C	SER-C	12
	KM4E419*DA	G-4	G-8	EBSSE-6-Z	EBSSE-6-Z	SER-C	SER-C	16

### R407A/ R407C<sup>†</sup>

6 FPI	KM6E153*DA	L-1-1/2	L-2-1/2	SBFDE-B-Z	SBFDE-B-Z	SER-A	SER-B	6
	KM6E184*DA	L-1-1/2	L-3	SBFDE-B-Z	SBFDE-B-Z	SER-B	SER-B	8
	KM6E311*DA	G-2-1/2	G-5	SBFDE-C-Z	SBFDE-C-Z	SER-B	SER-C	12
	KM6E374*DA	G-3	G-6	SBFDE-C-Z	EBSDE-7-Z	SER-C	SER-C	16
	KM6E469*DA	G-4	G-10	EBSDE-7-Z	EBSDE-7-Z	SER-C	SER-C	18
	KM6E564*DA	G-5	G-12	EBSDE-7-Z	EBSDE-10-Z	SER-C	SER-C	24
4 FPI	KM4E110*DA	L-1	L-2	SBFDE-A-Z	SBFDE-A-Z	SER-A	SER-A	4
	KM4E143*DA	L-1-1/2	L-2-1/2	SBFDE-B-Z	SBFDE-B-Z	SER-A	SER-B	6
	KM4E232*DA	L-2	L-4	SBFDE-C-Z	SBFDE-C-Z	SER-B	SER-B	9
	KM4E288*DA	G-2-1/2	G-5	SBFDE-C-Z	SBFDE-C-Z	SER-B	SER-C	12
	KM4E336*DA	G-3	G-6	SBFDE-C-Z	SBFDE-C-Z	SER-B	SER-C	12
	KM4E419*DA	G-4	G-8	EBSDE-7-Z	EBSDE-7-Z	SER-C	SER-C	16

### R448A/ R449A<sup>†</sup>

6 FPI	KM6E153*DA	L-1-1/2	L-2-1/2	SBFDE-B-Z	SBFDE-B-Z	SER-A	SER-B	6
	KM6E184*DA	L-1-1/2	L-3	SBFDE-B-Z	SBFDE-B-Z	SER-B	SER-B	8
	KM6E311*DA	G-2-1/2	G-5	SBFDE-C-Z	SBFDE-C-Z	SER-B	SER-C	12
	KM6E374*DA	G-3	G-6	EBSDE-7-Z	EBSDE-7-Z	SER-C	SER-C	16
	KM6E469*DA	G-4	G-10	EBSDE-7-Z	EBSDE-7-Z	SER-C	SER-C	18
	KM6E564*DA	G-5	G-12	EBSDE-10-Z	EBSDE-10-Z	SER-C	SER-C	24
4 FPI	KM4E110*DA	L-1	L-2	SBFDE-A-Z	SBFDE-A-Z	SER-A	SER-A	4
	KM4E143*DA	L-1-1/2	L-2-1/2	SBFDE-A-Z	SBFDE-A-Z	SER-A	SER-B	6
	KM4E232*DA	L-2	L-4	SBFDE-B-Z	SBFDE-C-Z	SER-B	SER-B	9
	KM4E288*DA	G-2-1/2	G-5	SBFDE-C-Z	SBFDE-C-Z	SER-B	SER-C	12
	KM4E336*DA	G-3	G-6	SBFDE-C-Z	EBSDE-7-Z	SER-B	SER-C	12
	KM4E419*DA	G-4	G-8	EBSDE-7-Z	EBSDE-7-Z	SER-C	SER-C	16

Note: The distributor lines are 3/16" tube & 21" long.

\* Each asterisk represents a variable character based on voltage ordered. See page 4 for nomenclature.

<sup>^</sup> TXV selections for Electric Defrost Models are based on -20°F suction temp., 8°F to 12°F evaporator TD. Contact factory for operating conditions outside of this range. Do not use pressure limiting TXVs when the condensing unit includes a CPR valve.

<sup>†</sup> SBFDE expansion valves are compatible with R407A, R448A and R449A/B. For other refrigerant valves, follow manufacturers selection guidelines.

Base models (no factory-mounted components) include nozzles sized for 100°F liquid shipped loose.

Distributor Nozzle and Expansion Valves - Hot Gas Defrost Models

Model Number KM*H/KM*G	Part Numbers						No. of Circuits
	Nozzle @ Liq. Temp.		TXV <sup>^</sup> @ Liq. Temp.		EEV @ Liq. Temp.		
	50°F	105°F	50°F	105°F	50°F	105°F	

R404A

6 FPI	KM6*153*DA	L-1-1/2	L-2-1/2	SBFSE-B-Z	SBFSE-B-Z	SER-B	SER-B	6
	KM6*184*DA	G-1-1/2	G-3	SBFSE-B-Z	SBFSE-C-Z	SER-B	SER-B	8
	KM6*311*DA	G-2-1/2	G-5	SBFSE-C-Z	EBSSE-6-Z	SER-B	SER-C	12
	KM6*374*DA	G-3	G-6	EBSSE-6-Z	EBSSE-6-Z	SER-C	SER-C	16
	KM6*469*DA	G-4	G-10	EBSSE-6-Z	EBSSE-7-1/2-Z	SER-C	SER-C	18
	KM6*564*DA	G-5	G-12	EBSSE-7-1/2-Z	EBSSE-10-Z	SER-C	SER-C	24
4 FPI	KM4*110*DA	L-1	L-2	SBFSE-A-Z	SBFSE-A-Z	SER-A	SER-A	4
	KM4*143*DA	L-1-1/2	L-2-1/2	SBFSE-A-Z	SBFSE-B-Z	SER-A	SER-B	6
	KM4*232*DA	G-2	G-4	SBFSE-B-Z	SBFSE-C-Z	SER-B	SER-B	9
	KM4*288*DA	G-2-1/2	G-5	SBFSE-C-Z	EBSSE-6-Z	SER-B	SER-C	12
	KM4*336*DA	G-3	G-6	SBFSE-C-Z	EBSSE-6-Z	SER-C	SER-C	12
	KM4*419*DA	G-4	G-8	EBSSE-6-Z	EBSSE-6-Z	SER-C	SER-C	16

R407A/ R407C<sup>†</sup>

6 FPI	KM6*153*DA	L-1-1/2	L-2-1/2	SBFDE-B-Z	SBFDE-B-Z	SER-A	SER-B	6
	KM6*184*DA	G-1-1/2	G-3	SBFDE-B-Z	SBFDE-B-Z	SER-B	SER-B	8
	KM6*311*DA	G-2-1/2	G-5	SBFDE-C-Z	SBFDE-C-Z	SER-B	SER-C	12
	KM6*374*DA	G-3	G-6	SBFDE-C-Z	EBSDE-7-Z	SER-C	SER-C	16
	KM6*469*DA	G-4	G-10	EBSDE-7-Z	EBSDE-7-Z	SER-C	SER-C	18
	KM6*564*DA	G-5	G-12	EBSDE-7-Z	EBSDE-10-Z	SER-C	SER-C	24
4 FPI	KM4*110*DA	L-1	L-2	SBFDE-A-Z	SBFDE-A-Z	SER-A	SER-A	4
	KM4*143*DA	L-1-1/2	L-2-1/2	SBFDE-B-Z	SBFDE-B-Z	SER-A	SER-B	6
	KM4*232*DA	G-2	G-4	SBFDE-C-Z	SBFDE-C-Z	SER-B	SER-B	9
	KM4*288*DA	G-2-1/2	G-5	SBFDE-C-Z	SBFDE-C-Z	SER-B	SER-C	12
	KM4*336*DA	G-3	G-6	SBFDE-C-Z	SBFDE-C-Z	SER-B	SER-C	12
	KM4*419*DA	G-4	G-8	EBSDE-7-Z	EBSDE-7-Z	SER-C	SER-C	16

R448A/ R449A<sup>†</sup>

6 FPI	KM6*153*DA	L-1-1/2	L-2-1/2	SBFDE-B-Z	SBFDE-B-Z	SER-A	SER-B	6
	KM6*184*DA	G-1-1/2	G-3	SBFDE-B-Z	SBFDE-B-Z	SER-B	SER-B	8
	KM6*311*DA	G-2-1/2	G-5	SBFDE-C-Z	SBFDE-C-Z	SER-B	SER-C	12
	KM6*374*DA	G-3	G-6	EBSDE-7-Z	EBSDE-7-Z	SER-C	SER-C	16
	KM6*469*DA	G-4	G-10	EBSDE-7-Z	EBSDE-7-Z	SER-C	SER-C	18
	KM6*564*DA	G-5	G-12	EBSDE-10-Z	EBSDE-10-Z	SER-C	SER-C	24
4 FPI	KM4*110*DA	L-1	L-2	SBFDE-A-Z	SBFDE-A-Z	SER-A	SER-A	4
	KM4*143*DA	L-1-1/2	L-2-1/2	SBFDE-A-Z	SBFDE-A-Z	SER-A	SER-B	6
	KM4*232*DA	G-2	G-4	SBFDE-B-Z	SBFDE-C-Z	SER-B	SER-B	9
	KM4*288*DA	G-2-1/2	G-5	SBFDE-C-Z	SBFDE-C-Z	SER-B	SER-C	12
	KM4*336*DA	G-3	G-6	SBFDE-C-Z	EBSDE-7-Z	SER-B	SER-C	12
	KM4*419*DA	G-4	G-8	EBSDE-7-Z	EBSDE-7-Z	SER-C	SER-C	16

Note: The distributor lines are 1/4" tube & 21" long.

\* Each asterisk represents a variable character based on defrost and voltage ordered. See page 4 for nomenclature.

<sup>^</sup> TXV selections are based on -20°F suction temp., 8°F to 12°F evaporator TD. Contact factory for operating conditions outside of this range. Do not use pressure limiting TXVs when the condensing unit includes a CPR valve.

<sup>†</sup> SBFDE expansion valves are compatible with R407A, R448A and R449A/B. For other refrigerant valves, follow manufacturers selection guidelines.

Base models (no factory-mounted components) include nozzles sized for 100°F liquid shipped loose.

# Medium Profile Unit Cooler

## Specifications - Air Defrost Models

Models	Fan Dia. (Inches)	Motor Data			Refrigerant Connections		No. of Hanger Slot Locations	Figure	Unit Dimensions (Inches)			Approx. Unit Wt. (Lbs.)
		Motor Qty.	HP	RPM	Liquid Line <sup>^</sup>	Suction			L	W	H	

### 6 FPI

KM6A182*DA	24	1	1/3	850	3/8	7/8	4	1	47-1/2	21-5/16	33-7/8	120
KM6A220*DA	24	1	1/3	850	3/8	7/8	4	1	47-1/2	21-5/16	33-7/8	120
KM6A276*DA	24	2	1/3	850	1/2	1-1/8	6	2	80-1/2	21-5/16	33-7/8	220
KM6A370*DA	24	2	1/3	850	1/2	1-1/8	6	2	80-1/2	21-5/16	33-7/8	220
KM6A442*DA	24	2	1/3	850	5/8	1-1/8	6	2	80-1/2	21-5/16	33-7/8	220
KM6A549*DA	24	3	1/3	850	5/8	1-3/8	8	3	113-9/16	21-5/16	33-7/8	316
KM6A658*DA	24	3	1/3	850	5/8	1-3/8	8	3	113-9/16	21-5/16	33-7/8	316

### Shipping Information - All Models

No. of Fans	Shipping Dimensions (Inches)			Approx. Ship Wt. (Lbs.)
	L	W	H	
1	60	43-1/4	48-1/2	346
2	93	43-1/4	48-1/2	510
3	126	43-1/4	48-1/2	673

\* Each asterisk represents a variable character based on voltage ordered. See page 4 for nomenclature.

<sup>^</sup> For units with mounted TXV components. See Nozzle/TXV table for distributor connection size when TXV is field installed.

1. For dimensional distance between hanger slots, consult model's corresponding dimension drawing. Hanger slots are 3/8" deep x 1" wide.
2. Drain is 1-1/4" NPT for all models.



Kramer's Medium Profile Unit Cooler can be used in combination with Next-Gen K-Series and Next-Gen II Condensing Units to provide complete refrigeration solutions for small to medium walk-ins

Specifications - Electric and Hot Gas Models

Models KM*E/G/H	Fan Diameter (Inches)	Motor Data			Refrigerant Connections			No. of Hanger Slot Locations
		Motor Qty.	HP	RPM	Liquid Line <sup>^</sup>	Suction	3-Pipe Hot Gas Line	

6 FPI

KM6*153*DA	24	1	1/3	850	3/8	1-1/8	1/2	4
KM6*184*DA	24	1	1/3	850	3/8	1-1/8	1/2	4
KM6*311*DA	24	2	1/3	850	1/2	1-5/8	5/8	6
KM6*374*DA	24	2	1/3	850	5/8	1-5/8	7/8	6
KM6*469*DA	24	3	1/3	850	5/8	2-1/8	7/8	8
KM6*564*DA	24	3	1/3	850	5/8	2-1/8	7/8	8

4 FPI

KM4*110*DA	24	1	1/3	850	3/8	1-1/8	1/2	4
KM4*143*DA	24	1	1/3	850	3/8	1-1/8	1/2	4
KM4*232*DA	24	2	1/3	850	1/2	1-3/8	5/8	6
KM4*288*DA	24	2	1/3	850	1/2	1-3/8	5/8	6
KM4*336*DA	24	3	1/3	850	1/2	1-5/8	5/8	8
KM4*419*DA	24	3	1/3	850	5/8	1-5/8	7/8	8

Models KM*E/G/H	Figure	Unit Dimensions (Inches)			Approx. Unit Wt. (Lbs.)
		L	W	H	

6 FPI

KM6*153*DA	1	47-1/2	21-5/16	33-7/8	120
KM6*184*DA	1	47-1/2	21-5/16	33-7/8	120
KM6*311*DA	2	80-1/2	21-5/16	33-7/8	220
KM6*374*DA	2	80-1/2	21-5/16	33-7/8	220
KM6*469*DA	3	113-9/16	21-5/16	33-7/8	320
KM6*564*DA	3	113-9/16	21-5/16	33-7/8	320

4 FPI

KM4*110*DA	1	47-1/2	21-5/16	33-7/8	120
KM4*143*DA	1	47-1/2	21-5/16	33-7/8	120
KM4*232*DA	2	80-1/2	21-5/16	33-7/8	220
KM4*288*DA	2	80-1/2	21-5/16	33-7/8	220
KM4*336*DA	3	113-9/16	21-5/16	33-7/8	320
KM4*419*DA	3	113-9/16	21-5/16	33-7/8	320

\* Each asterisk represents a variable character based on defrost and voltage ordered. See page 4 for nomenclature.

<sup>^</sup> For units with mounted TXV components. See Nozzle/TXV table for distributor connection size when TXV is field installed.

1. For dimensional distance between hanger slots, consult model's corresponding dimension drawing. Hanger slots are 3/8" deep x 1" wide.

2. Drain is 1-1/4" NPT for all models.

3. For shipping dimensions and weights, see Shipping Information table on page 14.

# Medium Profile Unit Cooler

## Specifications - All Models

Department of Energy Annual Walk-In Energy Factor (AWEF) Ratings			
Base Model Number	Defrost Type	FPI	AWEF

### Cooler Models<sup>1</sup>

KM6A182*DA	Air Defrost	6	9
KM6A220*DA	Air Defrost	6	9
KM6A276*DA	Air Defrost	6	9
KM6A370*DA	Air Defrost	6	9
KM6A442*DA	Air Defrost	6	9
KM6A549*DA	Air Defrost	6	9
KM6A658*DA	Air Defrost	6	9
KM6E153*DA	Electric Defrost	6	9
KM6E184*DA	Electric Defrost	6	9
KM6E311*DA	Electric Defrost	6	9
KM6E374*DA	Electric Defrost	6	9
KM6E469*DA	Electric Defrost	6	9
KM6E564*DA	Electric Defrost	6	9
KM6*153*DA	Hot Gas Defrost	6	9
KM6*184*DA	Hot Gas Defrost	6	9
KM6*311*DA	Hot Gas Defrost	6	9
KM6*374*DA	Hot Gas Defrost	6	9
KM6*469*DA	Hot Gas Defrost	6	9
KM6*564*DA	Hot Gas Defrost	6	9

Department of Energy Annual Walk-In Energy Factor (AWEF) Ratings			
Base Model Number	Defrost Type	FPI	AWEF

### Freezer Models<sup>2</sup>

KM6E153*DA	Electric Defrost	6	4.15
KM6E184*DA	Electric Defrost	6	4.15
KM6E311*DA	Electric Defrost	6	4.15
KM6E374*DA	Electric Defrost	6	4.15
KM6E469*DA	Electric Defrost	6	4.15
KM6E564*DA	Electric Defrost	6	4.15
KM4E110*DA	Electric Defrost	4	4.15
KM4E143*DA	Electric Defrost	4	4.15
KM4E232*DA	Electric Defrost	4	4.15
KM4E288*DA	Electric Defrost	4	4.15
KM4E336*DA	Electric Defrost	4	4.15
KM4E419*DA	Electric Defrost	4	4.15
KM6*153*DA	Hot Gas Defrost	6	4.15
KM6*184*DA	Hot Gas Defrost	6	4.15
KM6*311*DA	Hot Gas Defrost	6	4.15
KM6*374*DA	Hot Gas Defrost	6	4.15
KM6*469*DA	Hot Gas Defrost	6	4.15
KM6*564*DA	Hot Gas Defrost	6	4.15
KM4*110*DA	Hot Gas Defrost	4	4.15
KM4*143*DA	Hot Gas Defrost	4	4.15
KM4*232*DA	Hot Gas Defrost	4	4.15
KM4*288*DA	Hot Gas Defrost	4	4.15
KM4*336*DA	Hot Gas Defrost	4	4.15
KM4*419*DA	Hot Gas Defrost	4	4.15

\* Each asterisk represents a variable character based upon voltage ordered. See page 4 for nomenclature.

1. If the model has a numerical value in the table above, the following statement applies: "The refrigeration system is designed and certified for use in walk-in cooler applications."
2. If the model has a numerical value in the table above, the following statement applies: "The refrigeration system is designed and certified for use in walk-in freezer applications."



Physical Dimensions

FIGURE 1 - SINGLE FAN

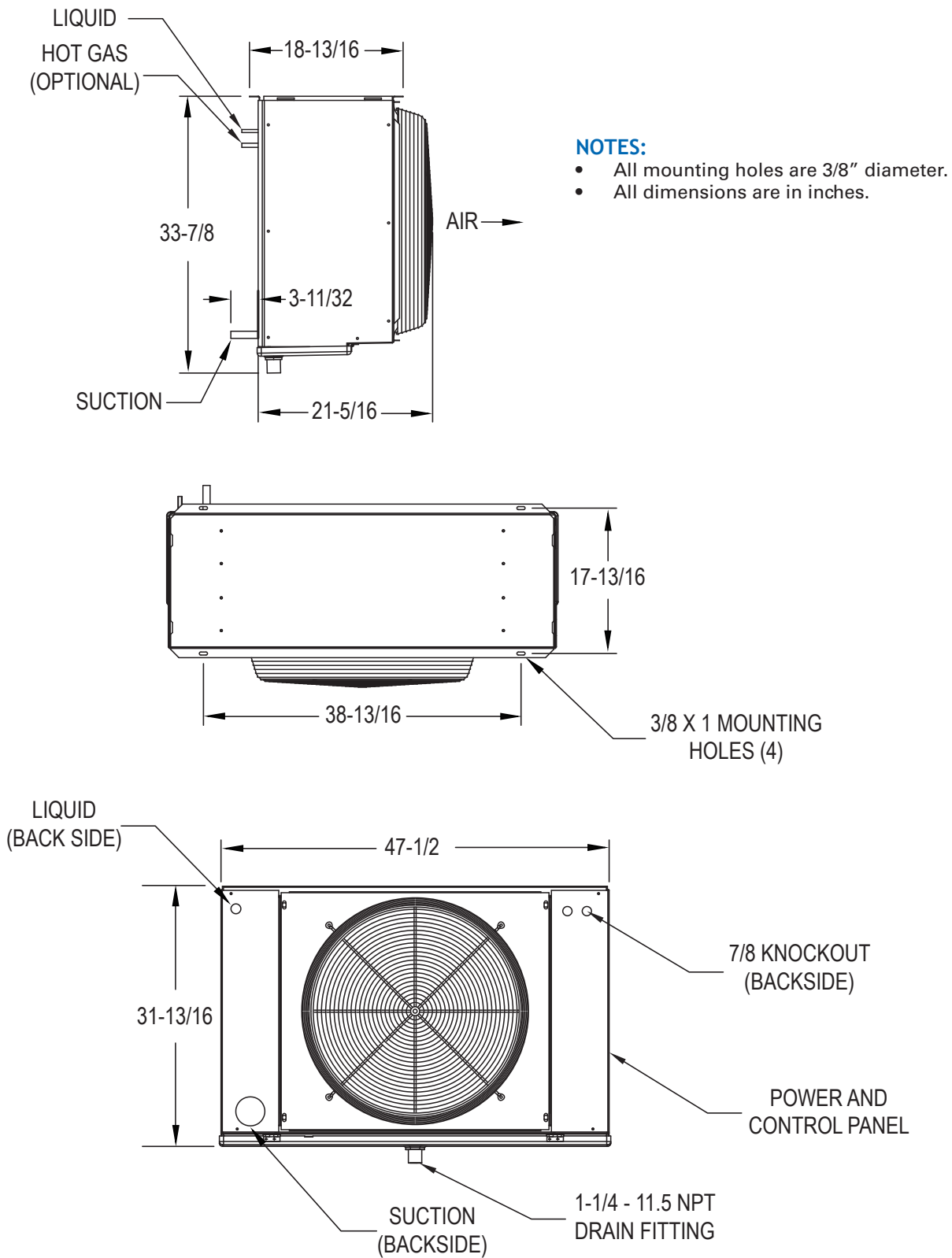

## Physical Dimensions

FIGURE 2- TWO FAN

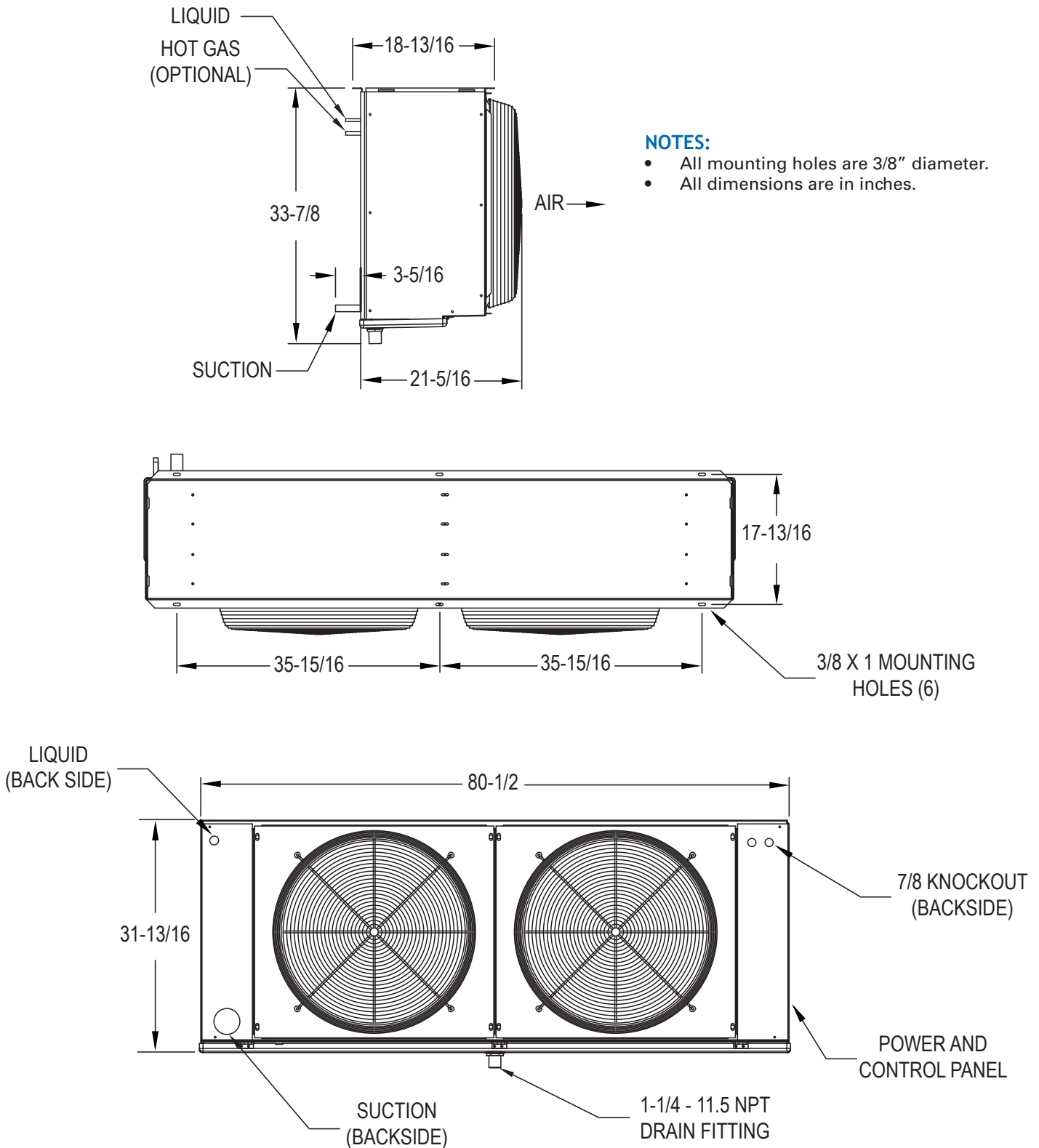

Physical Dimensions

FIGURE 3- THREE FAN

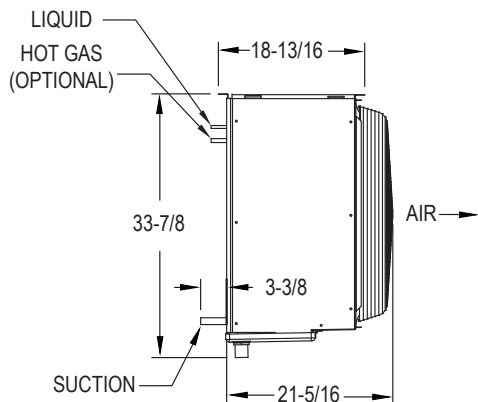

NOTES:

- All mounting holes are 3/8" diameter.
- All dimensions are in inches.

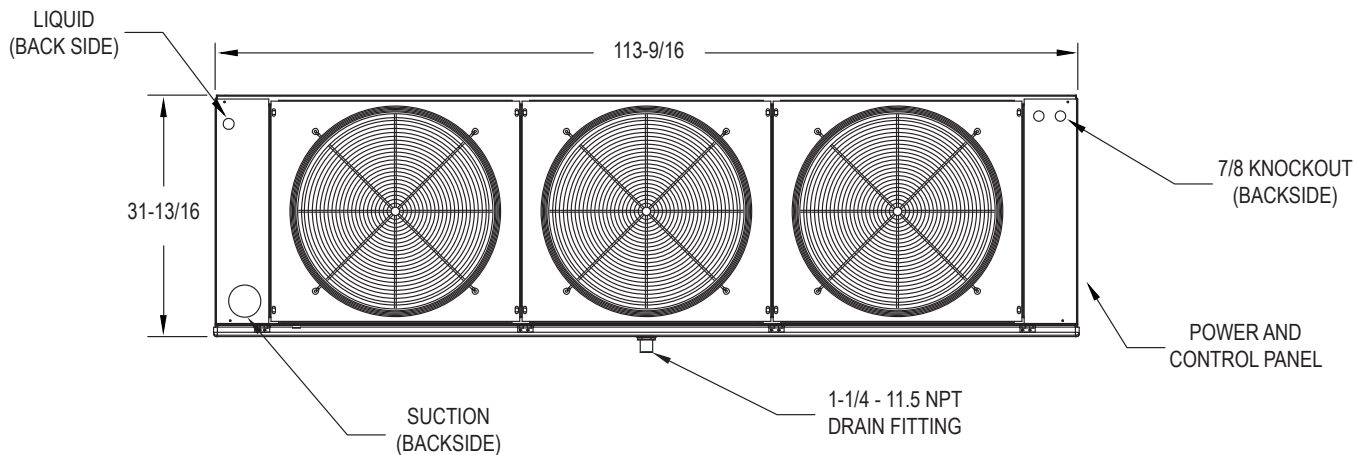
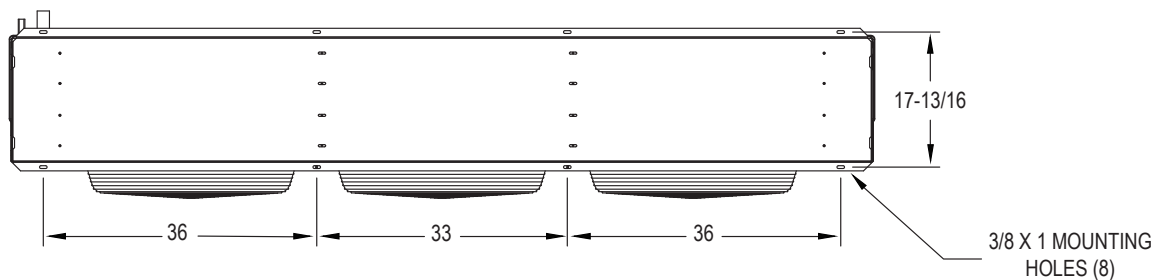

*Due to continuing product development, specifications are subject to change without notice.*