

WAREHOUSE

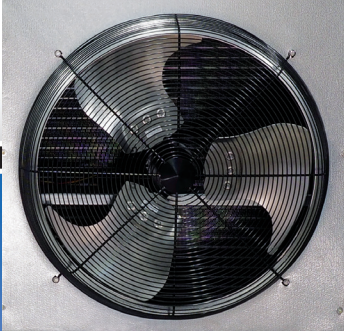

WAREHOUSE UNIT COOLER

AIR, ELECTRIC & HOT GAS MODELS

34,500 TO 282,500 BTUH

MEDIUM TO LARGE WALK-INS

COOLER AND FREEZER APPLICATIONS

Designed for Walk-in Coolers and Freezers
in boxes 3,000 sq. ft. and larger



Models are designed exclusively for use in walk-in coolers and freezers 3,000 sq. ft and larger and fall outside of the July 2020 Department of Energy Annual Walk-in Energy Factor (AWEF) regulations



Features

Kramer's Warehouse Unit Coolers are the ideal evaporator solution for large walk-in coolers and freezers. Designed with efficiency, performance and service in mind, the Warehouse Unit Cooler line is optimized to cover Cold Storage applications in the most effective way. The Warehouse units feature rail-mount three-phase motors with standard or high static pressure prop fan blades. All units are circuited for multiple refrigerants and feature optimized circuit patterns to maximize performance. Warehouse Unit Coolers have several enhanced service features including rail-mount motors, new high efficiency fan and venturi designs, enhanced surface coil tubing, easily removable fan guards and modular fan panels, face mount defrost heaters, hinged drain pans and shipping pallets designed to facilitate easy installation.

Warehouse Unit Coolers are designed exclusively for applications 3,000 sq. ft and larger.

SIZES

There are a wide array of sizes to match your specific application requirements ranging from 34,500 to 282,500 BTUH at a 10°TD. Models are available with air flow spanning a range of 6,875 to 27,500 CFM.

HOUSING

Each unit is constructed with a rust-free, heavy gauge, textured, aluminum housing which is light weight yet extremely durable. Models feature hinged drain pans to allow for convenient servicing and maintenance. Pre-drilled hanger holes are provided on all units for fast installation.

COIL

Seamless copper tubes are staggered and mechanically expanded into heavy gauge corrugated aluminum fins to assure maximum heat transfer. Die formed fin collars are provided for accurate fin spacing. Heavy gauge hangers are fastened directly to the tube sheet of the coil to provide high structural strength. Electric Defrost and Hot Gas Defrost Models are available in both 6 FPI and 4 FPI.

MOTORS

Models are offered with three-phase motors with standard or high static pressure prop fan blades. If you require a High-Static fan blade in an application above freezing, please contact factory.

FANS & FAN GUARDS

Powerful heavy-duty aluminum fans are individually balanced to provide vibration free operation. Standard heavy-gauge wire fan guards are UL/cUL-approved epoxy coated for corrosion resistance. High static pressure prop fan blades are also available. Air throw for Warehouse Unit Coolers is 120 ft. with standard fan.

REFRIGERANTS

Large Unit Coolers are optimized for multiple refrigerants including R404A, R407A, R448A, R449A and R744 DX (CO₂). Please specify system refrigerant requirements when ordering. A separate compartment is provided for all refrigerant connections which allows ample room for internal mounting of expansion valves.

ELECTRICAL

Available in 208-230V/3 or 460V/3. A large compartment is supplied for all electrical components and is easily accessible by removing the end panel. All models are UL and cUL listed.

AIR DEFROST

Air Defrost models (KW6A) are designed for use in coolers at +35°F and warmer.

ELECTRIC DEFROST

Electric Defrost models (KW6E or KW4E) are designed for use in coolers and freezers between 35°F to -30°F. Defrost heaters are mounted on the air intake side of the unit for optimal performance and easy maintenance. A lower heater is installed inside the drain pan for fast, reliable drainage. Adjustable defrost termination, fan delay and heater safety controls are factory mounted for optimum performance of each control function.

HOT GAS DEFROST

There are three types of Hot Gas Defrost models available: 3-pipe Hot Gas models (KW*H or KW*K), 2-pipe Hot Gas Reverse Cycle units (KW*G or KW*L) and Thermobank (KH*T). Hot Gas Defrost models are designed for use in coolers and freezers between 35°F and -30°F. Models are offered with electric or hot gas drain pans. 3-pipe Hot Gas and 2-pipe Hot Gas Reverse Cycle units include adjustable defrost termination and fan delay controls which are factory mounted for optimum performance of each control function. Refer to the current Kramer Technical Bulletin for piping. Reverse Cycle units can also be used for Alternating Evaporator Systems. Thermobank units have the defrost termination and fan delay controls mounted in the Thermobank condensing unit.

Optional Features

- EcoNet® Enabled Controller¹ (factory-installed)
- EcoNet® Command Center (loose)
- Reverse Connections
- Thermostat - Mechanical or Electric (mounted or loose)
- Thermostatic Expansion Valve (mounted or loose)
- Electronic Expansion Valve (mounted or loose)
- Liquid Line Solenoid Valve (mounted or loose)
- Insulated Drain Pan
- Painted Cabinet (White or Black)
- Stainless Steel Cabinet
- Coated Coil (Bronz-Glow, or Electrofin®)
- Heat Exchanger (loose)

NOTES

1. EcoNet Control Package includes: EEV; suction pressure transducer; suction; entering air coil temp. thermistors; thru-the-door disconnect switch; local on-board two-row backlit LCD display and push-button adjustments. (Controller replaces TXV, liquid line solenoid valve, room thermostat, defrost termination and fan delay, and time clock.)

Highlighted Features and Options

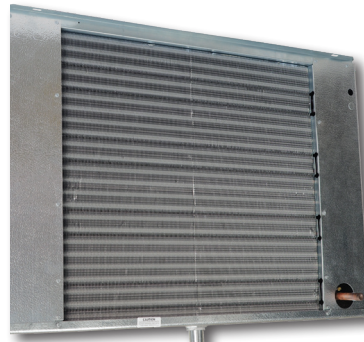



FANS AND HOUSING

- 30" heavy duty aluminum fans are balanced for vibration-free operation
- High efficiency deep draw venturi provide optimal air flow
- Hinged panels that can easily be removed
- NSF approved

COILS AND DEFROST HEATERS

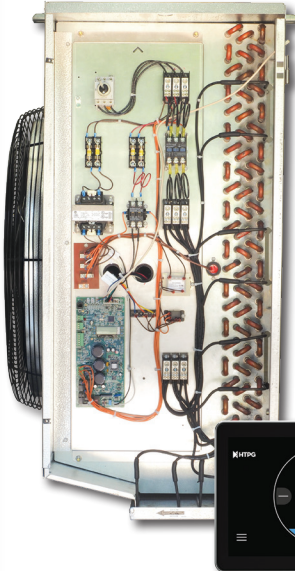
- Available in 4 or 6 fins per inch (FPI)
- Electric defrost heaters are mounted on the air intake coil face to provide optimal performance and easy service access
- The drain pan heater is affixed to the drain pan and is easily accessed for service or cleaning





ECONET ENABLED UNIT COOLERS (OPTIONAL)

- Developed in conjunction with Rheem Manufacturing specifically for walk-in coolers and freezers — it builds on the reliability and efficiency of Rheem's EcoNet technology
- Saves energy in refrigeration systems through precise superheat and space temperature control, fan cycling, and controlling how often the system goes into defrost based on compressor runtime
- Eliminates unnecessary defrosts
 - Maximizes energy efficiency with less compressor runtime
 - Reduces fan speed to 50% during off cycle for energy savings
- Can be used with a condensing unit in single and multiple evaporator installations as a group
- Optional **EcoNet Command Center** with intuitive graphical interface controls up to 32 devices (including the Command Center) through one display, provides continuous communication between system components, and the remote mount display allows for EcoNet Enabled Unit Coolers to be programmed, monitored and troubleshot outside of the space being cooled

ELECTRICAL AND PIPING

- End panels slide out for easy service from the front or sides of the unit
- Ample room in electrical and piping compartments for easy access

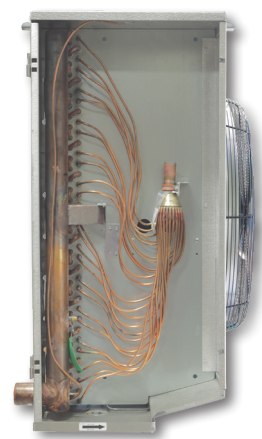
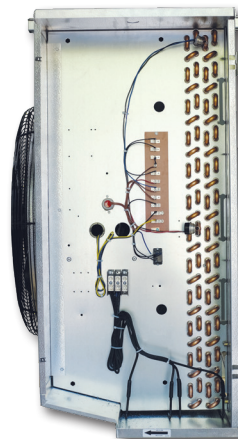

MODEL NUMBER NOMENCLATURE
CONFIGURABLE BASE MODEL

K	W	6	E	143	E	T	A
Brand	Style	Fins Per Inch (FPI)	Defrost Type	BTUH in Thousands	Unit Voltage	Motor Type	Vintage
K = Kramer	W = Warehouse Z = Reverse Connections	4 6	A = Air E = Electric H = Hot Gas 3-Pipe with Electric Drain Pan G = Hot Gas Reverse with Electric Drain Pan K = Hot Gas 3-Pipe with Hot Gas Drain Pan L = Hot Gas Reverse with Hot Gas Drain Pan T = Thermobank		E = 208-230/3/60 G = 460/3/60	T = Three Phase H = Three Phase with High-Static (Pressure Prop) Fan Blades	

**FAN GUARDS EASILY REMOVABLE FOR QUICK ACCESS TO
FAN BLADES AND RAIL-MOUNTED MOTORS**

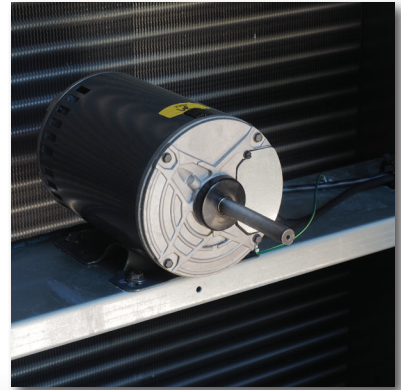
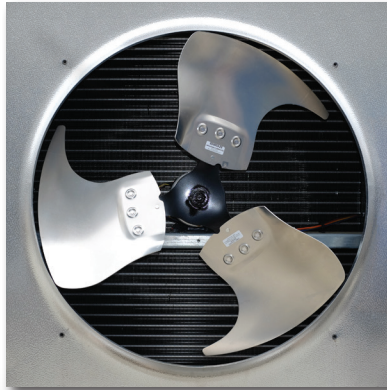
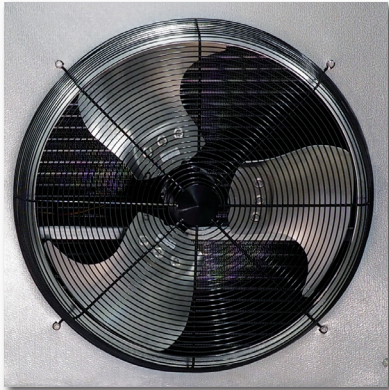

Application Rating and Electrical Data - Air Defrost Models - Three-Phase Motor - 6 FPI

Model Number	BTUH Capacity @ 25°F S.T. & 10°F TD		CFM	No. of Fans	Total Fan Motor AMPS	
	R404A / R744 DX (CO ₂)	R407A/ R448A/ R449A [^]			Three-Phase Motor	
					Motor Voltage	
					208-230V/3	460V/3
KW6A034*TA	34,500	40,400	7,080	1	4.1	2.0
KW6A047*TA	47,000	55,000	7,010			
KW6A058*TA	58,200	68,900	6,875			
KW6A069*TA	69,600	80,900	14,160	2	8.2	4.0
KW6A094*TA	94,500	111,500	14,030			
KW6A117*TA	117,200	138,800	13,750			
KW6A143*TA	143,100	167,000	21,040	3	12.3	6.0
KW6A176*TA	176,000	207,500	20,625			
KW6A190*TA	190,100	226,100	28,050	4	16.4	8.0
KW6A234*TA	234,900	282,500	27,500			

Model Number	208-230V/3				460V/3			
	MCA		MOPD		MCA		MOPD	
	Base Model	EcoNet Enabled ¹	Base Model	EcoNet Enabled ¹	Base Model	EcoNet Enabled ¹	Base Model	EcoNet Enabled ¹
KW6A034*TA	15.0	15.0	20	20	15.0	15.0	20	20
KW6A047*TA								
KW6A058*TA								
KW6A069*TA	15.0	15.0	20	20	15.0	15.0	20	20
KW6A094*TA								
KW6A117*TA								
KW6A143*TA	15.0	15.0	20	20	15.0	15.0	20	20
KW6A176*TA								
KW6A190*TA	17.4	19.4	20	20	15.0	15.0	20	20
KW6A234*TA								

* Each asterisk represents a variable character based on voltage ordered. See page 4 for nomenclature.

[^] R407A, R448A and R449A are rated at dew point temperature. Use R407A capacity ratings for R407C and R407F.

1. EcoNet Enabled Units are not powered by Condensing Unit so Defrost Heaters are incorporated into shown MCA/MOPD.

Warehouse models are designed exclusively for use in walk-in coolers and freezers 3,000 sq. ft and larger and fall outside of the July 2020 Department of Energy Annual Walk-in Energy Factor (AWEF) regulations

Warehouse Unit Cooler

Application Rating and Electrical Data - Electric Defrost Models - Three-Phase Motor

Model Number	BTUH Capacity @ -20°F S.T. & 10°F TD		CFM	No. of Fans	Total Fan Motor AMPS	
	R404A / R744 DX (CO ₂)	R407A/ R448A/ R449A [^]			Three-Phase Motor	
					Motor Voltage	
					208-230V/3	460V/3

6 FPI

KW6E036*TA	36,400	41,900	7,080	1	4.1	2.0
KW6E047*TA	47,900	54,600	7,010			
KW6E059*TA	59,200	67,900	6,875			
KW6E072*TA	72,500	83,500	14,160	2	8.2	4.0
KW6E096*TA	96,100	109,400	14,030			
KW6E120*TA	120,000	137,200	13,750			
KW6E143*TA	143,600	163,100	21,040	3	12.3	6.0
KW6E179*TA	179,500	206,600	20,625			
KW6E216*TA	216,200	246,100	27,500	4	16.4	8.0

4 FPI

KW4E038*TA	38,300	43,600	7,010	1	4.1	2.0
KW4E048*TA	48,900	56,000	6,875			
KW4E077*TA	77,300	88,600	14,030	2	8.2	4.0
KW4E097*TA	97,000	111,000	13,750			
KW4E115*TA	115,600	131,200	21,040	3	12.3	6.0
KW4E145*TA	145,700	166,400	20,625			
KW4E182*TA	182,200	206,500	27,500	4	16.4	8.00

Model Number	208-230V/3				Heater Amps			Heater Watts
	MCA		MOPD		208-230V/3			
	Base Model	EcoNet Enabled ²	Base Model	EcoNet Enabled ²	No. of Circuits	Amps Each Circuit	Total Heater Amps	

6 FPI

KW6E036ETA	15.0	16.4	20	20	1	14.4	14.4	6,000
KW6E047ETA								
KW6E059ETA								
KW6E072ETA	15.0	30.9	20	35	1	28.9	28.9	12,000
KW6E096ETA								
KW6E120ETA								
KW6E143ETA	15.0	45.3	20	50	1	43.3	43.3	18,000
KW6E179ETA								
KW6E216ETA	17.4	59.7	20	60	2	28.9	57.7	24,000

4 FPI

KW4E038ETA	15.0	16.4	20	20	1	14.4	14.4	6,000
KW4E048ETA								
KW4E077ETA	15.0	30.9	20	35	1	28.9	28.9	12,000
KW4E097ETA								
KW4E115ETA	15.0	45.3	20	50	1	43.3	43.3	18,000
KW4E145ETA								
KW4E182ETA	17.4	59.7	20	60	2	28.9	57.7	24,000

See notes on page 7.

Application Rating and Electrical Data - Electric Defrost Models - Three-Phase Motor cont.

Model Number	460V/3				Heater Amps			Heater Watts
	MCA		MOPD		460V/3			
	Base Model	EcoNet Enabled ²	Base Model	EcoNet Enabled ²	No. of Circuits	Amps Each Circuit	Total Heater Amps	

6 FPI

KW6E036GTA KW6E047GTA KW6E059GTA	15.0	15.0	20	20	1	7.5	7.5	6,000
KW6E072GTA KW6E096GTA KW6E120GTA	15.0	16.1	20	20	1	15.1	15.1	12,000
KW6E143GTA KW6E179GTA	15.0	23.6	20	25	1	22.6	22.6	18,000
KW6E216GTA	15.0	31.1	20	35	1	30.1	30.1	24,000

4 FPI

KW4E038GTA KW4E048GTA	15.0	15.0	20	20	1	7.5	7.5	6,000
KW4E077GTA KW4E097GTA	15.0	16.1	20	20	1	15.1	15.1	12,000
KW4E115GTA KW4E145GTA	15.0	23.6	20	25	1	22.6	22.6	18,000
KW4E182GTA	15.0	31.1	20	35	1	30.1	30.1	24,000

See notes below.

Notes:

Capacity Correction for Electric and Hot Gas Defrost Evaporators						
S.S.T. (Dew)	20°F	0°F	-10°F	-20°F	-30°F	-40°F
Multiply Capacity by:	1.15	1.075	1.0375	1	0.9625	0.925

2. EcoNet Enabled Units are not powered by Condensing Unit so Defrost Heaters are incorporated into shown MCA/MOPD.

* Each asterisk represents a variable character based on voltage ordered. See page 4 for nomenclature.

^ R407A, R448A and R449A are rated at dew point temperature. Use R407A capacity ratings for R407C and R407F.

High static models are capable of .35" water column external static pressure for duct or air flow accessories. Models with high static fan blade should not be used without the presence of external static pressure.

Warehouse models are designed exclusively for use in walk-in coolers and freezers 3,000 sq. ft and larger and fall outside of the July 2020 Department of Energy Annual Walk-in Energy Factor (AWEF) regulations

Warehouse Unit Cooler

Application Rating and Electrical Data - Electric Defrost Models - Three-Phase Motor with High-Static Fan Blades

Model Number	BTUH Capacity @ -20°F S.T. & 10°F TD		CFM	No. of Fans	Total Fan Motor AMPS	
					Three-Phase Motor with High-Static Fan Blades	
					Motor Voltage	
	R404A / R744 DX (CO ₂)	R407A/ R448A/ R449A [^]			208-230V/3	460V/3

6 FPI

KW6E036*HA	36,400	41,900	7,080	1	6.4	3.2
KW6E047*HA	47,900	54,600	7,010			
KW6E059*HA	59,200	67,900	6,875			
KW6E072*HA	72,500	83,500	14,160	2	12.8	6.4
KW6E096*HA	96,100	109,400	14,030			
KW6E120*HA	120,000	137,200	13,750			
KW6E143*HA	143,600	163,100	21,040	3	19.2	9.6
KW6E179*HA	179,500	206,600	20,625			
KW6E216*HA	216,200	246,100	27,500			

4 FPI

KW4E038*HA	38,300	43,600	7,010	1	6.4	3.2
KW4E048*HA	48,900	56,000	6,875			
KW4E077*HA	77,300	88,600	14,030	2	12.8	6.4
KW4E097*HA	97,000	111,000	13,750			
KW4E115*HA	115,600	131,200	21,040	3	19.2	9.6
KW4E145*HA	145,700	166,400	20,625			
KW4E182*HA	182,200	206,500	27,500	4	25.6	12.8

Model Number	208-230V/3				Heater Amps			Heater Watts
	MCA		MOPD		208-230V/3			
	Base Model	EcoNet Enabled ²	Base Model	EcoNet Enabled ²	No. of Circuits	Amps Each Circuit	Total Heater Amps	

6 FPI

KW6E036EHA	15.0	16.4	20	20	1	14.4	14.4	6,000
KW6E047EHA								
KW6E059EHA								
KW6E072EHA	15.0	30.9	20	35	1	28.9	28.9	12,000
KW6E096EHA								
KW6E120EHA								
KW6E143EHA	20.8	45.3	25	50	1	43.3	43.3	18,000
KW6E179EHA								
KW6E216EHA	27.2	59.7	30	60	2	28.9	57.7	24,000

4 FPI

KW4E038EHA	15.0	16.4	20	20	1	14.4	14.4	6,000
KW4E048EHA								
KW4E077EHA	15.0	30.9	20	35	1	28.9	28.9	12,000
KW4E097EHA								
KW4E115EHA	20.8	45.3	25	50	1	43.3	43.3	18,000
KW4E145EHA								
KW4E182EHA	27.2	59.7	30	60	2	28.9	57.7	24,000

See notes on page 7.

Application Rating and Electrical Data - Electric Defrost Models - Three-Phase Motor with High-Static Fan Blades cont.

Model Number	460V/3				Heater Amps			Heater Watts
	MCA		MOPD		460V/3			
	Base Model	EcoNet Enabled ²	Base Model	EcoNet Enabled ²	No. of Circuits	Amps Each Circuit	Total Heater Amps	

6 FPI

KW6E036GHA KW6E047GHA KW6E059GHA	15.0	15.0	20	20	1	7.5	7.5	6,000
KW6E072GHA KW6E096GHA KW6E120GHA	15.0	16.1	20	20	1	15.1	15.1	12,000
KW6E143GHA KW6E179GHA	15.0	23.6	20	25	1	22.6	22.6	18,000
KW6E216GHA	15.0	31.1	20	35	1	30.1	30.1	24,000

4 FPI

KW4E038GHA KW4E048GHA	15.0	15.0	20	20	1	7.5	7.5	6,000
KW4E077GHA KW4E097GHA	15.0	16.1	20	20	1	15.1	15.1	12,000
KW4E115GHA KW4E145GHA	15.0	23.6	20	25	1	22.6	22.6	18,000
KW4E182GHA	15.0	31.1	20	35	1	30.1	30.1	24,000

See notes on page 7.

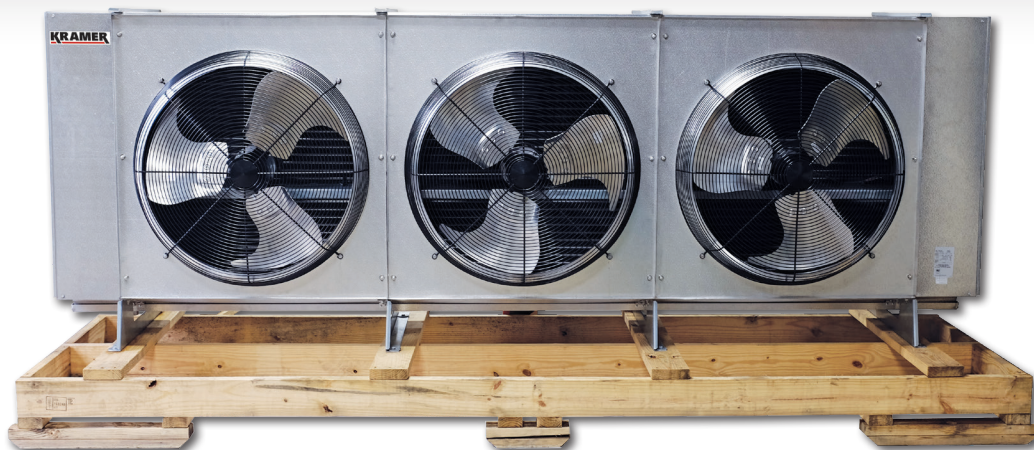

SUPPORTS ARE BOLTED TO PALLET AND UNIT COOLER FOR PRODUCT SAFETY AND QUICKER INSTALLATION

Warehouse Unit Cooler

Performance and Electrical Data - Hot Gas 3-Pipe Defrost Models - Three-Phase Motor

Hot Gas Model Number (KW*H KW*K)	BTUH Capacity @ -20°F S.T. & 10°F TD ¹		CFM	No. of Fans	Total Fan Motor AMPS		MCA	
	R404A	R407A/ R448A/ R449A [^]			Three-Phase Motor		208-230V/3	460V/3
					208-230V/3	460V/3		

6 FPI

KW6*036*TA	36,400	41,900	7,080	1	4.1	2.0	15.0	15.0
KW6*047*TA	47,900	54,600	7,010					
KW6*059*TA	59,200	67,900	6,875					
KW6*072*TA	72,500	83,500	14,160	2	8.2	4.0	15.0	15.0
KW6*096*TA	96,100	109,400	14,030					
KW6*120*TA	120,000	137,200	13,750					
KW6*143*TA	143,600	163,100	21,040	3	12.3	6.0	15.0	15.0
KW6*179*TA	179,500	206,600	20,625					
KW6*216*TA	216,200	246,100	27,500					

4 FPI

KW4*038*TA	38,300	43,600	7,010	1	4.1	2.0	15.0	15.0
KW4*048*TA	48,900	56,000	6,875					
KW4*077*TA	77,300	88,600	14,030	2	18.2	4.0	15.0	15.0
KW4*097*TA	97,000	111,000	13,750					
KW4*115*TA	115,600	131,200	21,040	3	12.3	6.0	15.0	15.0
KW4*145*TA	145,700	166,400	20,625					
KW4*182*TA	182,200	206,500	27,500					

Hot Gas Model Number (KW*H KW*K)	MOPD	Electric Drain Pan Heater Amps		Heater Watts
		208-230V/1	460V/1	

6 FPI

KW6*036*TA	20	8.3	4.3	2,000
KW6*047*TA				
KW6*059*TA				
KW6*072*TA	20	16.7	8.7	4,000
KW6*096*TA				
KW6*120*TA				
KW6*143*TA	20	25.0	13.0	6,000
KW6*179*TA				
KW6*216*TA				

4 FPI

KW4*038*TA	20	8.3	4.3	2,000
KW4*048*TA				
KW4*077*TA	20	16.7	8.7	4,000
KW4*097*TA				
KW4*115*TA	20	25.0	13.0	6,000
KW4*145*TA				
KW4*182*TA	20	33.3	17.4	8,000

Hot Gas 3-Pipe Model

The system uses 3 pipes — 1 for liquid line, 1 for suction line and 1 for hot gas. The hot gas is taken from the discharge line, between the compressor and the condenser, through a hot-gas solenoid valve to the distributor tee then through the coil.

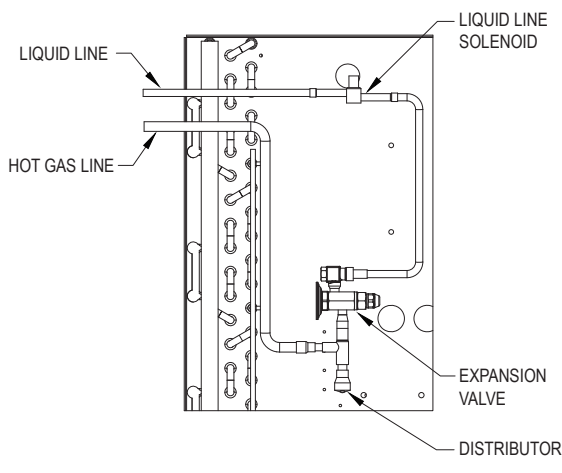

* Each asterisk represents a variable character based on defrost and voltage ordered. Hot Gas 3-Pipe Version (H - Hot Gas Defrost 3-Pipe with Electric Drain Pan Heater, K - Hot Gas Defrost 3-Pipe with Hot Gas Drain Pan). See page 4 for nomenclature.

1. See capacity correction table and additional notes on page 7.

Performance and Electrical Data - Hot Gas 3-Pipe Defrost Models - Three-Phase Motors with High-Static Fan Blades

Hot Gas Model Number (KW*H KW*K)	BTUH Capacity @ -20°F S.T. & 10°F TD ¹		CFM	No. of Fans	Total Fan Motor AMPS		MCA	
	R404A	R407A/ R448A/ R449A [^]			Three-Phase Motor with High-Static Fan Blades			
					208-230V/3	460V/3	208-230V/3	460V/3

6 FPI

KW6*036*HA	36,400	41,900	7,080	1	6.4	3.2	15.0	15.0
KW6*047*HA	47,900	54,600	7,010					
KW6*059*HA	59,200	67,900	6,875					
KW6*072*HA	72,500	83,500	14,160	2	12.8	6.4	15.0	15.0
KW6*096*HA	96,100	109,400	14,030					
KW6*120*HA	120,000	137,200	13,750					
KW6*143*HA	143,600	163,100	21,040	3	19.2	9.6	20.8	15.0
KW6*179*HA	179,500	206,600	20,625					
KW6*216*HA	216,200	246,100	27,500					

4 FPI

KW4*038*HA	38,300	43,600	7,010	1	6.4	3.2	15.0	15.0
KW4*048*HA	48,900	56,000	6,875					
KW4*077*HA	77,300	88,600	14,030	2	12.8	6.4	15.0	15.0
KW4*097*HA	97,000	111,000	13,750					
KW4*115*HA	115,600	131,200	21,040	3	19.2	9.6	20.8	15.0
KW4*145*HA	145,700	166,400	20,625					
KW4*182*HA	182,200	206,500	27,500	4	25.6	12.8	27.2	15.0

Hot Gas Model Number (KW*H KW*K)	MOPD		Electric Drain Pan Heater Amps		Heater Watts
	208-230V/3	460V/3	208-230V/1	460V/1	

6 FPI

KW6*036*HA	20	20	8.3	4.3	2,000
KW6*047*HA					
KW6*059*HA					
KW6*072*HA	20	20	16.7	8.7	4,000
KW6*096*HA					
KW6*120*HA					
KW6*143*HA	25	20	25.0	13.0	6,000
KW6*179*HA					
KW6*216*HA	30	20	33.3	17.4	8,000

4 FPI

KW4*038*HA	20	20	8.3	4.3	2,000
KW4*048*HA					
KW4*077*HA	20	20	16.7	8.7	4,000
KW4*097*HA					
KW4*115*HA	25	20	25.0	13.0	6,000
KW4*145*HA					
KW4*182*HA	30	20	33.3	17.4	8,000

* Each asterisk represents a variable character based on defrost and voltage ordered. Hot Gas 3-Pipe Version (H - Hot Gas Defrost 3-Pipe with Electric Drain Pan Heater, K - Hot Gas Defrost 3-Pipe with Hot Gas Drain Pan). See page 4 for nomenclature.

1. See capacity correction table and additional notes on page 7.

Warehouse Unit Cooler

Performance and Electrical Data - Hot Gas Reverse Cycle Defrost Models - Three-Phase Motor

Hot Gas Model Number (KW*G KW*L)	BTUH Capacity @ -20°F S.T. & 10°F TD ¹		CFM	No. of Fans	Total Fan Motor AMPS		MCA	
	R404A	R407A/ R448A/ R449A [^]			Three-Phase Motor			
					208-230V/3	460V/3	208-230V/3	460V/3

6 FPI

KW6*036*TA	36,400	41,900	7,080	1	4.1	2.0	15.0	15.0
KW6*047*TA	47,900	54,600	7,010					
KW6*059*TA	59,200	67,900	6,875					
KW6*072*TA	72,500	83,500	14,160	2	8.2	4.0	15.0	15.0
KW6*096*TA	96,100	109,400	14,030					
KW6*120*TA	120,000	137,200	13,750					
KW6*143*TA	143,600	163,100	21,040	3	12.3	6.0	15.0	15.0
KW6*179*TA	179,500	206,600	20,625					
KW6*216*TA	216,200	246,100	27,500	4	16.4	8.0	17.4	15.0

4 FPI

KW4*038*TA	38,300	43,600	7,010	1	4.1	2.0	15.0	15.0
KW4*048*TA	48,900	56,000	6,875					
KW4*077*TA	77,300	88,600	14,030	2	18.2	4.0	15.0	15.0
KW4*097*TA	97,000	111,000	13,750					
KW4*115*TA	115,600	131,200	21,040	3	12.3	6.0	15.0	15.0
KW4*145*TA	145,700	166,400	20,625					
KW4*182*TA	182,200	206,500	27,500	4	16.4	8.0	17.4	15.0

Hot Gas Model Number (KW*G KW*L)	MOPD	Electric Drain Pan Heater Amps		Heater Watts
		208-230V/1	460V/1	

6 FPI

KW6*036*TA	20	8.3	4.3	2,000
KW6*047*TA				
KW6*059*TA				
KW6*072*TA	20	16.7	8.7	4,000
KW6*096*TA				
KW6*120*TA				
KW6*143*TA	20	25.0	13.0	6,000
KW6*179*TA				
KW6*216*TA	20	33.3	17.4	8,000

4 FPI

KW4*038*TA	20	8.3	4.3	2,000
KW4*048*TA				
KW4*077*TA	20	16.7	8.7	4,000
KW4*097*TA				
KW4*115*TA	20	25.0	13.0	6,000
KW4*145*TA				
KW4*182*TA	20	33.3	17.4	8,000

Hot Gas Reverse Cycle 2-Pipe Model

A changeover valve is located in the discharge suction line of the compressor, so that when defrost is required, the valve changes over from the normal refrigeration flow so that the discharged gas flows into the suction connection and bypasses TX valve.

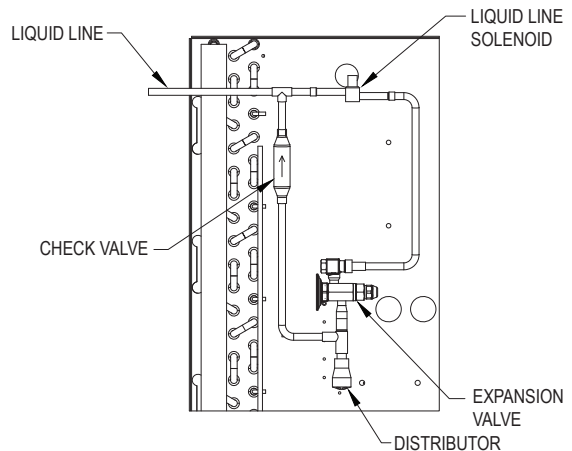

* Each asterisk represents a variable character based on defrost and voltage ordered. Hot Gas Reverse Cycle (G - Hot Gas Defrost Reverse Cycle with Electric Drain Pan Heater, L - Hot Gas Defrost Reverse Cycle with Hot Gas Drain Pan). See page 4 for nomenclature.

1. See capacity correction table and additional notes on page 7.

Performance and Electrical Data - Hot Gas Reverse Cycle Defrost Models - Three-Phase Motor with High-Static Fan Blades

Hot Gas Model Number (KW*G KW*L)	BTUH Capacity @ -20°F S.T. & 10°F TD ¹		CFM	No. of Fans	Total Fan Motor AMPS		MCA	
	R404A	R407A/ R448A/ R449A [^]			Three-Phase Motor with High-Static Fan Blades		208-230V/3	460V/3
					208-230V/3	460V/3		

6 FPI

KW6*036*HA	36,400	41,900	7,080	1	6.4	3.2	15.0	15.0
KW6*047*HA	47,900	54,600	7,010					
KW6*059*HA	59,200	67,900	6,875					
KW6*072*HA	72,500	83,500	14,160	2	12.8	6.4	15.0	15.0
KW6*096*HA	96,100	109,400	14,030					
KW6*120*HA	120,000	137,200	13,750					
KW6*143*HA	143,600	163,100	21,040	3	19.2	9.6	20.8	15.0
KW6*179*HA	179,500	206,600	20,625					
KW6*216*HA	216,200	246,100	27,500					

4 FPI

KW4*038*HA	38,300	43,600	7,010	1	6.4	3.2	15.0	15.0
KW4*048*HA	48,900	56,000	6,875					
KW4*077*HA	77,300	88,600	14,030	2	12.8	6.4	15.0	15.0
KW4*097*HA	97,000	111,000	13,750					
KW4*115*HA	115,600	131,200	21,040	3	19.2	9.6	20.8	15.0
KW4*145*HA	145,700	166,400	20,625					
KW4*182*HA	182,200	206,500	27,500	4	25.6	12.8	27.2	15.0

Hot Gas Model Number (KW*G KW*L)	MOPD		Electric Drain Pan Heater Amps		Heater Watts
	208-230V/3	460V/3	208-230V/1	460V/1	

6 FPI

KW6*036*HA	20	20	8.3	4.3	2,000
KW6*047*HA					
KW6*059*HA					
KW6*072*HA	20	20	16.7	8.7	4,000
KW6*096*HA					
KW6*120*HA					
KW6*143*HA	25	20	25.0	13.0	6,000
KW6*179*HA					
KW6*216*HA	30	20	33.3	17.4	8,000

4 FPI

KW4*038*HA	20	20	8.3	4.3	2,000
KW4*048*HA					
KW4*077*HA	20	20	16.7	8.7	4,000
KW4*097*HA					
KW4*115*HA	25	20	25.0	13.0	6,000
KW4*145*HA					
KW4*182*HA	30	20	33.3	17.4	8,000

* Each asterisk represents a variable character based on defrost and voltage ordered. Hot Gas Reverse Cycle (G - Hot Gas Defrost Reverse Cycle with Electric Drain Pan Heater, L - Hot Gas Defrost Reverse Cycle with Hot Gas Drain Pan). See page 4 for nomenclature.

1. See capacity correction table and additional notes on page 7.

Application Rating and Electrical Data - Thermobank Hot Gas Defrost Models - Three-Phase Motor

Hot Gas Model Number (KW*T)	BTUH Capacity @ -20°F S.T. & 10°F TD ¹		CFM	No. of Fans	Total Fan Motor AMPS		208-230V/3		460V/3	
	R404A	R407A/ R448A/ R449A [^]			Three-Phase Motor		MCA	MOPD	MCA	MOPD
					208-230V/3	460V/3	Base Model	Base Model	Base Model	Base Model

6 FPI

KW6T036*TA	36,400	41,900	7,080	1	4.1	2.0	15.0	20	15.0	20
KW6T047*TA	47,900	54,600	7,010							
KW6T059*TA	59,200	67,900	6,875							
KW6T072*TA	72,500	83,500	14,160	2	8.2	4.0	15.0	20	15.0	20
KW6T096*TA	96,100	109,400	14,030							
KW6T120*TA	120,000	137,200	13,750							
KW6T143*TA	143,600	163,100	21,040	3	12.3	6.0	15.0	20	15.0	20
KW6T179*TA	179,500	206,600	20,625							
KW6T216*TA	216,200	246,100	27,500							

4 FPI

KW4T038*TA	38,300	43,600	7,010	1	4.1	2.0	15.0	20	15.0	20
KW4T048*TA	48,900	56,000	6,875							
KW4T077*TA	77,300	88,600	14,030	2	18.2	4.0	15.0	20	15.0	20
KW4T097*TA	97,000	111,000	13,750							
KW4T115*TA	115,600	131,200	21,040	3	12.3	6.0	15.0	20	15.0	20
KW4T145*TA	145,700	166,400	20,625							
KW4T182*TA	182,200	206,500	27,500	4	16.4	8.0	17.4	20	15.0	20

* Each asterisk represents a variable character based on voltage ordered. See page 4 for nomenclature.

1. See capacity correction table and additional notes on page 7.

Thermobank Hot Gas Defrost Model

Thermobank coils use unique hot gas design for a fast coil defrost. The new coil designs include all required solenoid and check valves installed at the factory. In refrigeration mode the liquid line solenoid is open to feed the expansion valve and coil. During the defrost the liquid solenoid is closed. The hot gas solenoid opens feeding warm refrigerant to the coil and drain pan to remove frost. When the defrost reaches termination pressure, normal operation resumes.

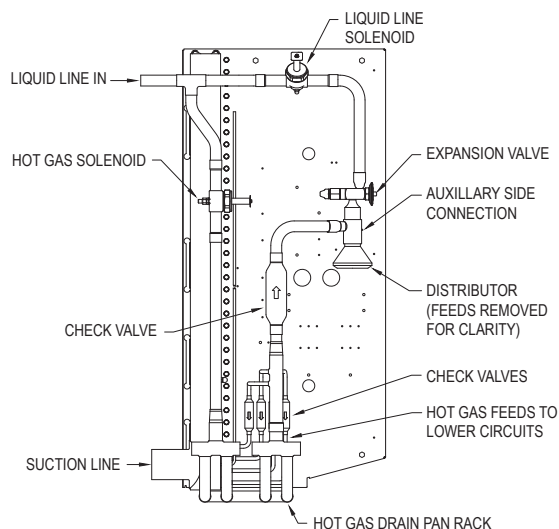

Application Rating and Electrical Data - Thermobank Hot Gas Defrost Models - Three-Phase Motor with High-Static Fan Blades

Hot Gas Model Number (KW*T)	BTUH Capacity @ -20°F S.T. & 10°F TD ¹		CFM	No. of Fans	Total Fan Motor AMPS		208-230V/3		460V/3	
	R404A	R407A/ R448A/ R449A [^]			Three-Phase Motor with High-Static Fan Blades		MCA	MOPD	MCA	MOPD
					208-230V/3	460V/3	Base Model	Base Model	Base Model	Base Model

6 FPI

KW6T036*HA	36,400	41,900	7,080	1	6.4	3.2	15.0	20	15.0	20
KW6T047*HA	47,900	54,600	7,010							
KW6T059*HA	59,200	67,900	6,875							
KW6T072*HA	72,500	83,500	14,160	2	12.8	6.4	15.0	20	15.0	20
KW6T096*HA	96,100	109,400	14,030							
KW6T120*HA	120,000	137,200	13,750							
KW6T143*HA	143,600	163,100	21,040	3	19.2	9.6	20.8	25	15.0	20
KW6T179*HA	179,500	206,600	20,625							
KW6T216*HA	216,200	246,100	27,500							

4 FPI

KW4T038*HA	38,300	43,600	7,010	1	6.4	3.2	15.0	20	15.0	20
KW4T048*HA	48,900	56,000	6,875							
KW4T077*HA	77,300	88,600	14,030	2	12.8	6.4	15.0	20	15.0	20
KW4T097*HA	97,000	111,000	13,750							
KW4T115*HA	115,600	131,200	21,040	3	19.2	9.6	20.8	25	15.0	20
KW4T145*HA	145,700	166,400	20,625							
KW4T182*HA	182,200	206,500	27,500							

* Each asterisk represents a variable character based on voltage ordered. See page 4 for nomenclature.

1. See capacity correction table and additional notes on page 7.

Thermobank Hot Gas Defrost Model

Thermobank coils use unique hot gas design for a fast coil defrost. The new coil designs include all required solenoid and check valves installed at the factory. In refrigeration mode the liquid line solenoid is open to feed the expansion valve and coil. During the defrost the liquid solenoid is closed. The hot gas solenoid opens feeding warm refrigerant to the coil and drain pan to remove frost. When the defrost reaches termination pressure, normal operation resumes.

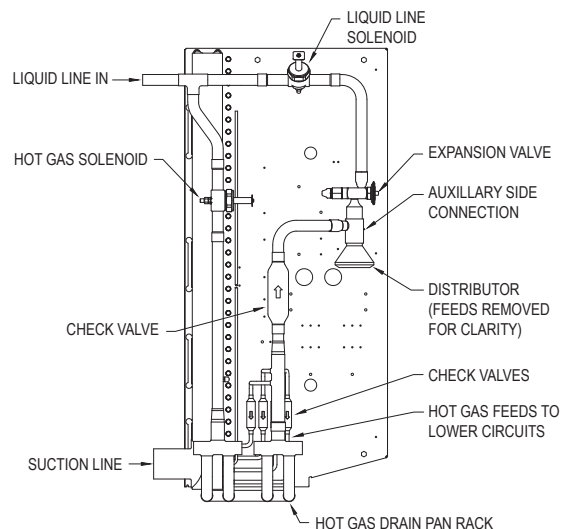

Distributor Nozzle and Expansion Valves - Air Defrost Models

Model Number	Part Numbers						No. of Circuits
	Nozzle @ Liq. Temp.		TXV [^] @ Liq. Temp.		EEV @ Liq. Temp.		
	50°F	100°F	50°F	100°F	50°F	100°F	

R404A

6 FPI	KW6A034**	G#1-1/2	G#4	SBFSE-B-C	SBFSE-C-C	SER-C	SER-C	6
	KW6A047**	G#1-1/2	G#5	SBFSE-C-C	OSE-6-C	SER-C	SER-C	6
	KW6A058**	E#2	E#6	OSE-6-C	OSE-6-C	SER-C	SER-D	12
	KW6A069**	E#2-1/2	E#10	OSE-6-C	OSE-6-C	SER-C	SER-D	9
	KW6A094**	C#3	C#12	OSE-6-C	OSE-9-C	SER-D	SER-D	18
	KW6A117**	C#4	C#15	OSE-9-C	OSE-9-C	SER-D	SERI-F	18
	KW6A143**	C#5	C#20	OSE-9-C	OSE-12-C	SER-D	SERI-F	18
	KW6A176**	C#6	C#25	OSE-12-C	OSE-21-C	SERI-F	SERI-G	24
	KW6A190**	A#8	A#25	OSE-12-C	OSE-21-C	SERI-F	SERI-G	27
KW6A234**	A#10	A#30	OSE-12-C	OSE-21-C	SERI-F	SERI-G	36	

R407A/ R448A/ R449A†

6 FPI	KW6A034**	G#1-1/2	G#4	SBFDE-B-C	SBFDE-C-C	SER-B	SER-C	6
	KW6A047**	G#1-1/2	G#5	SBFDE-C-C	SBFDE-C-C	SER-C	SER-C	6
	KW6A058**	E#2	E#6	SBFDE-C-C	EBSDE-7-C	SER-C	SER-C	12
	KW6A069**	E#2-1/2	E#8	SBFDE-C-C	EBSDE-7-C	SER-C	SER-D	9
	KW6A094**	C#4	C#12	EBSDE-7-C	EBSDE-10-C	SER-D	SER-D	18
	KW6A117**	C#4	C#15	EBSDE-7-C	ODE-12-C	SER-D	SERI-F	18
	KW6A143**	C#5	C#17	EBSDE-10-C	ODE-12-C	SER-D	SERI-F	18
	KW6A176**	C#6	C#20	EBSDE-12-C	ODE-17-C	SERI-F	SERI-F	24
	KW6A190**	A#8	A#25	EBSDE-12-C	ODE-17-C	SERI-F	SERI-G	27
KW6A234**	A#10	A#30	EBSDE-17-C	ODE-28-C	SERI-F	SERI-G	36	

Note: The distributor lines are 1/4" tube & 31" long.

* Each asterisk represents a variable character based on voltage and motor ordered. See page 4 for nomenclature.

^ TXV selections are based on +25°F suction temp., 8°F to 12°F evaporator TD. Contact factory for operating conditions outside of this range.

† SBFDE, ODE, and EBSDE expansion valves are compatible with R407A, R448A and R449A/B. For other valves, follow manufacturers selection guidelines.

Base models (no factory-mounted components) include nozzles sized for 100°F liquid shipped loose.



Kramer's Warehouse Unit Cooler can be used in combination with Next-Gen II Condensing Units to provide complete refrigeration solutions for medium and large walk-ins 3,000 sq. ft. and larger

Distributor Nozzle and Expansion Valves - Electric Defrost Models

Model Number	Part Numbers						No. of Circuits
	Nozzle @ Liq. Temp.		TXV [^] @ Liq. Temp.		EEV @ Liq. Temp.		
	50°F	100°F	50°F	100°F	50°F	100°F	

R404A

6 FPI	KW6E036**	E#3	E#8	SBFSE-C-Z	EBSSE-6-Z	SER-C	SER-C	9
	KW6E047**	E#4	E#10	OSE-6-Z	EBSSE-7-1/2-Z	SER-C	SER-C	9
	KW6E059**	E#5	E#12	OSE-6-Z	EBSSE-10-Z	SER-C	SER-D	12
	KW6E072**	C#6	C#17	OSE-6-Z	EBSSE-10-Z	SER-C	SER-D	18
	KW6E096**	C#10	C#20	OSE-9-Z	EBSSE-13-Z	SER-D	SER-D	18
	KW6E120**	C#12	C#25	OSE-12-Z	OSE-21-Z	SER-D	SERI-F	24
	KW6E143**	A#15	A#35	OSE-12-Z	OSE-30-Z	SER-D	SERI-F	27
	KW6E179**	A#17	A#40	OSE-21-Z	OSE-30-Z	SERI-F	SERI-G	36
KW6E216**	A#20	A#50	OSE-35-Z	OSE-45-Z	SERI-F	SERI-G	36	
4 FPI	KW4E038**	E#3	E#8	SBFSE-C-Z	OSE-6-Z	SER-C	SER-C	9
	KW4E048**	E#4	E#12	OSE-6-Z	OSE-6-Z	SER-C	SER-C	12
	KW4E077**	C#8	C#17	OSE-9-Z	OSE-12-Z	SER-C	SER-D	18
	KW4E097**	C#10	C#20	OSE-9-Z	OSE-12-Z	SER-D	SER-D	24
	KW4E115**	A#12	A#30	OSE-12-Z	OSE-21-Z	SER-D	SERI-F	27
	KW4E145**	A#15	A#35	OSE-12-Z	OSE-30-Z	SER-D	SERI-F	36
KW4E182**	A#20	A#40	OSE-21-Z	OSE-30-Z	SERI-F	SERI-G	36	

R407A/ R448A/ R449A[†]

6 FPI	KW6E036**	E#2-1/2	E#6	SBFDE-C-Z	ODE-7-Z	SER-B	SER-C	9
	KW6E047**	E#4	E#8	EBSDE-7-Z	ODE-12-Z	SER-C	SER-C	9
	KW6E059**	E#5	E#12	EBSDE-7-Z	ODE-12-Z	SER-C	SER-C	12
	KW6E072**	C#6	C#15	EBSDE-10-Z	ODE-12-Z	SER-C	SER-D	18
	KW6E096**	C#8	C#17	ODE-12-Z	ODE-17-Z	SER-D	SER-D	18
	KW6E120**	C#12	C#25	ODE-17-Z	ODE-28-Z	SER-D	SER-D	24
	KW6E143**	A#15	A#30	ODE-17-Z	ODE-28-Z	SER-D	SERI-F	27
	KW6E179**	A#17	A#35	ODE-28-Z	ODE-40-Z	SERI-F	SERI-G	36
KW6E216**	A#20	A#40	ODE-28-Z	ODE-45-Z	SERI-F	SERI-G	36	
4 FPI	KW4E038**	E#3	E#6	SBFDE-C-Z	ODE-7-Z	SER-C	SER-C	9
	KW4E048**	E#4	E#8	SBFDE-C-Z	ODE-7-Z	SER-C	SER-C	12
	KW4E077**	C#6	C#15	ODE-12-Z	ODE-12-Z	SER-C	SER-D	18
	KW4E097**	C#8	C#17	ODE-12-Z	ODE-17-Z	SER-D	SER-D	24
	KW4E115**	A#12	A#20	ODE-17-Z	ODE-28-Z	SER-D	SER-D	27
	KW4E145**	A#15	A#30	ODE-17-Z	ODE-28-Z	SER-D	SERI-F	36
KW4E182**	A#17	A#35	ODE-28-Z	ODE-40-Z	SERI-F	SERI-G	36	

Note: The distributor lines are 1/4" tube & 31" long.

* Each asterisk represents a variable character based on voltage and motor ordered. See page 4 for nomenclature.

[^] TXV selections for Electric Defrost Models are based on -20°F suction temp., 8°F to 12°F evaporator TD. Contact factory for operating conditions outside of this range. Do not use pressure limiting TXVs when the condensing unit includes a CPR valve.

[†] SBFDE, ODE, and EBSDE expansion valves are compatible with R407A, R448A and R449A/B. For other valves, follow manufacturers selection guidelines.

Base models (no factory-mounted components) include nozzles sized for 100°F liquid shipped loose.

Warehouse Unit Cooler

Distributor Nozzle and Expansion Valves - Hot Gas Defrost Models

Model Number (KW*H, KW*G, KW*K, KW*L, KW*T)	Part Numbers						No. of Circuits
	Nozzle @ Liq. Temp.		TXV [^] @ Liq. Temp.		EEV @ Liq. Temp.		
	50°F	100°F	50°F	100°F	50°F	100°F	

R404A

6 FPI	KW6*036**	E#3	E#8	SBFSE-C-Z	EBSSE-6-Z	SER-C	SER-C	9
	KW6*047**	E#4	E#10	OSE-6-Z	EBSSE-7-1/2-Z	SER-C	SER-C	9
	KW6*059**	E#5	E#12	OSE-6-Z	EBSSE-10-Z	SER-C	SER-D	12
	KW6*072**	C#6	C#17	OSE-6-Z	EBSSE-10-Z	SER-C	SER-D	18
	KW6*096**	C#10	C#20	OSE-9-Z	EBSSE-13-Z	SER-D	SER-D	18
	KW6*120**	C#12	C#25	OSE-12-Z	OSE-21-Z	SER-D	SERI-F	24
	KW6*143**	A#15	A#35	OSE-12-Z	OSE-30-Z	SER-D	SERI-F	27
4 FPI	KW6*179**	A#17	A#40	OSE-21-Z	OSE-30-Z	SERI-F	SERI-G	36
	KW6*216**	A#20	A#50	OSE-35-Z	OSE-45-Z	SERI-F	SERI-G	36
	KW4*038**	E#3	E#8	SBFSE-C-Z	OSE-6-Z	SER-C	SER-C	9
	KW4*048**	E#4	E#12	OSE-6-Z	OSE-6-Z	SER-C	SER-C	12
	KW4*077**	C#8	C#17	OSE-9-Z	OSE-12-Z	SER-C	SER-D	18
	KW4*097**	C#10	C#20	OSE-9-Z	OSE-12-Z	SER-D	SER-D	24
	KW4*115**	A#12	A#30	OSE-12-Z	OSE-21-Z	SER-D	SERI-F	27
4 FPI	KW4*145**	A#15	A#35	OSE-12-Z	OSE-30-Z	SER-D	SERI-F	36
	KW4*182**	A#20	A#40	OSE-21-Z	OSE-30-Z	SERI-F	SERI-G	36

R407A/ R448A/ R449A[†]

6 FPI	KW6*036**	E#2-1/2	E#6	SBFDE-C-Z	ODE-7-Z	SER-B	SER-C	9
	KW6*047**	E#4	E#8	EBSDE-7-Z	ODE-12-Z	SER-C	SER-C	9
	KW6*059**	E#5	E#12	EBSDE-7-Z	ODE-12-Z	SER-C	SER-C	12
	KW6*072**	C#6	C#15	EBSDE-10-Z	ODE-12-Z	SER-C	SER-D	18
	KW6*096**	C#8	C#17	ODE-12-Z	ODE-17-Z	SER-D	SER-D	18
	KW6*120**	C#12	C#25	ODE-17-Z	ODE-28-Z	SER-D	SER-D	24
	KW6*143**	A#15	A#30	ODE-17-Z	ODE-28-Z	SER-D	SERI-F	27
4 FPI	KW6*179**	A#17	A#35	ODE-28-Z	ODE-40-Z	SERI-F	SERI-G	36
	KW6*216**	A#20	A#40	ODE-28-Z	ODE-45-Z	SERI-F	SERI-G	36
	KW4*038**	E#3	E#6	SBFDE-C-Z	ODE-7-Z	SER-C	SER-C	9
	KW4*048**	E#4	E#8	SBFDE-C-Z	ODE-7-Z	SER-C	SER-C	12
	KW4*077**	C#6	C#15	ODE-12-Z	ODE-12-Z	SER-C	SER-D	18
	KW4*097**	C#8	C#17	ODE-12-Z	ODE-17-Z	SER-D	SER-D	24
	KW4*115**	A#12	A#20	ODE-17-Z	ODE-28-Z	SER-D	SER-D	27
4 FPI	KW4*145**	A#15	A#30	ODE-17-Z	ODE-28-Z	SER-D	SERI-F	36
	KW4*182**	A#17	A#35	ODE-28-Z	ODE-40-Z	SERI-F	SERI-G	36

Note: The distributor lines are 1/4" tube & 31" long.

* Each asterisk represents a variable character based on defrost, voltage and motor ordered. See page 4 for nomenclature.

[^] TXV selections for Hot Gas Defrost Models are based on -20°F suction temp., 8°F to 12°F evaporator TD. Contact factory for operating conditions outside of this range. Do not use pressure limiting TXVs when the condensing unit includes a CPR valve.

[†] SBFDE, ODE, and EBSDE expansion valves are compatible with R407A, R448A and R449A/B. For other valves, follow manufacturers selection guidelines.

Base models (no factory-mounted components) include nozzles sized for 100°F liquid shipped loose.

Specifications - Air Defrost Models - Three-Phase Motor

Model Number	Fan Diameter (Inches)	Motor Data			Refrigerant Connections		No. of Hanger Slot Locations	Figure
		Motor Qty.	HP	RPM	Liquid Line [^]	Suction Line		

6 FPI

KW6A034*TA	30	1	1	850	1/2	1-1/8	4	1
KW6A047*TA	30	1	1	850	1/2	1-3/8	4	1
KW6A058*TA	30	1	1	850	5/8	1-5/8	4	1
KW6A069*TA	30	2	1	850	5/8	1-5/8	6	2
KW6A094*TA	30	2	1	850	7/8	2-1/8	6	2
KW6A117*TA	30	2	1	850	7/8	2-1/8	6	2
KW6A143*TA	30	3	1	850	7/8	2-1/8	8	3
KW6A176*TA	30	3	1	850	1-1/8	2-1/8	8	3
KW6A190*TA	30	4	1	850	1-1/8	2-1/8	10	4
KW6A234*TA	30	4	1	850	1-1/8	2-1/8	10	4

Model Number	Unit Dimensions (Inches)			Approx. Unit Wt. (Lbs.)
	L	W	H	

6 FPI

KW6A034*TA	59-7/8	27-3/8	49-1/4	303
KW6A047*TA	59-7/8	27-3/8	49-1/4	303
KW6A058*TA	59-7/8	27-3/8	49-1/4	303
KW6A069*TA	99-7/8	27-3/8	49-1/4	509
KW6A094*TA	99-7/8	27-3/8	49-1/4	509
KW6A117*TA	99-7/8	27-3/8	49-1/4	509
KW6A143*TA	139-7/8	27-3/8	49-1/4	682
KW6A176*TA	139-7/8	27-3/8	49-1/4	682
KW6A190*TA	179-7/8	27-3/8	49-1/4	1,050
KW6A234*TA	179-7/8	27-3/8	49-1/4	1,050

Shipping Information - All Models				
No. of Fans	Shipping Dimensions (Inches)			Est. Ship Wt. (Lbs.)
	L	W	H	
1	69	42	66	480
2	109	42	66	750
3	146	42	66	1,030
4	189	42	66	1,360

* Each asterisk represents a variable character based on voltage ordered. See page 4 for nomenclature.

[^] For units with mounted TXV components. See Nozzle/TXV table for distributor connection size when TXV is field installed.

1. For dimensional distance between hanger slots, consult model's corresponding dimension drawing. Hanger slots are 1" deep x 1/2" wide.
2. Drain is 1-1/4" NPT for all models.

TYPICAL APPLICATIONS:



Medium to Large Warehouses



Cold Storage Warehouses



Walk-in Coolers and Freezers

Warehouse Unit Cooler

Specifications - Electric and Hot Gas Defrost Models - Three-Phase Motor

Model Number KW*E/G/ H/K/L	Fan Diameter (Inches)	Motor Data			Refrigerant Connections			No. of Hanger Slot Locations	Figure
		Motor Qty.	HP	RPM	Liquid Line [^]	Suction	3-Pipe Hot Gas Line		

6 FPI

KW6*036*TA	30	1	1	850	1/2	2-1/8	1-1/8	4	1
KW6*047*TA	30	1	1	850	5/8	2-1/8	1-1/8	4	1
KW6*059*TA	30	1	1	850	5/8	2-1/8	1-1/8	4	1
KW6*072*TA	30	2	1	850	5/8	2-1/8	1-1/8	6	2
KW6*096*TA	30	2	1	850	7/8	3-1/8	1-1/8	6	2
KW6*120*TA	30	2	1	850	7/8	3-1/8	1-1/8	6	2
KW6*143*TA	30	3	1	850	1-1/8	3-1/8	1-3/8	8	3
KW6*179*TA	30	3	1	850	1-1/8	3-1/8	1-3/8	8	3
KW6*216*TA	30	4	1	850	1-1/8	3-1/8	1-3/8	10	4

4 FPI

KW4*038*TA	30	1	1	850	1/2	2-1/8	1-1/8	4	1
KW4*048*TA	30	1	1	850	5/8	2-1/8	1-1/8	4	1
KW4*077*TA	30	2	1	850	5/8	2-1/8	1-1/8	6	2
KW4*097*TA	30	2	1	850	7/8	3-1/8	1-1/8	6	2
KW4*115*TA	30	3	1	850	7/8	3-1/8	1-3/8	8	3
KW4*145*TA	30	3	1	850	1-1/8	3-1/8	1-3/8	8	3
KW4*182*TA	30	4	1	850	1-1/8	3-1/8	1-3/8	10	4

Model Number RW*E/G/ H/K/L	Unit Dimensions (Inches)			Approx. Unit Wt. (Lbs.)
	L	W	H	

6 FPI

KW6*036*TA	59-7/8	27-3/8	49-1/4	303
KW6*047*TA	59-7/8	27-3/8	49-1/4	303
KW6*059*TA	59-7/8	27-3/8	49-1/4	303
KW6*072*TA	99-7/8	27-3/8	49-1/4	509
KW6*096*TA	99-7/8	27-3/8	49-1/4	509
KW6*120*TA	99-7/8	27-3/8	49-1/4	509
KW6*143*TA	139-7/8	27-3/8	49-1/4	682
KW6*179*TA	139-7/8	27-3/8	49-1/4	682
KW6*216*TA	179-7/8	27-3/8	49-1/4	1,050

4 FPI

KW4*038*TA	59-7/8	27-3/8	49-1/4	303
KW4*048*TA	59-7/8	27-3/8	49-1/4	303
KW4*077*TA	99-7/8	27-3/8	49-1/4	509
KW4*097*TA	99-7/8	27-3/8	49-1/4	509
KW4*115*TA	139-7/8	27-3/8	49-1/4	682
KW4*145*TA	139-7/8	27-3/8	49-1/4	682
KW4*182*TA	179-7/8	27-3/8	49-1/4	1,050

* Each asterisk represents a variable character based on defrost and motor ordered. See page 4 for nomenclature.

[^] For units with mounted TXV components. See Nozzle/ TXV table for distributor connection size when TXV is field installed.

1. For dimensional distance between hanger slots, consult model's corresponding dimension drawing. Hanger slots are 1" deep x 1/2" wide.
2. Drain is 1-1/4" NPT for all models.
3. For shipping dimensions and weights, see Shipping Information table on page 19.

Specifications - Electric and Hot Gas Defrost Models - Three-Phase Motor with High-Static Fan Blades

Model Number KW*E/G/H/ K/L/T	Fan Diameter (Inches)	Motor Data			Refrigerant Connections			No. of Hanger Slot Locations	Figure
		Motor Qty.	HP	RPM	Liquid Line [^]	Suction	3-Pipe Hot Gas Line		

6 FPI

KW6*036*HA	30	1	1.5	1140	1/2	2-1/8	1-1/8	4	1
KW6*047*HA	30	1	1.5	1140	5/8	2-1/8	1-1/8	4	1
KW6*059*HA	30	1	1.5	1140	5/8	2-1/8	1-1/8	4	1
KW6*072*HA	30	2	1.5	1140	5/8	2-1/8	1-1/8	6	2
KW6*096*HA	30	2	1.5	1140	7/8	3-1/8	1-1/8	6	2
KW6*120*HA	30	2	1.5	1140	7/8	3-1/8	1-1/8	6	2
KW6*143*HA	30	3	1.5	1140	1-1/8	3-1/8	1-3/8	8	3
KW6*179*HA	30	3	1.5	1140	1-1/8	3-1/8	1-3/8	8	3
KW6*216*HA	30	4	1.5	1140	1-1/8	3-1/8	1-3/8	10	4

4 FPI

KW4*038*HA	30	1	1.5	1140	1/2	2-1/8	1-1/8	4	1
KW4*048*HA	30	1	1.5	1140	5/8	2-1/8	1-1/8	4	1
KW4*077*HA	30	2	1.5	1140	5/8	2-1/8	1-1/8	6	2
KW4*097*HA	30	2	1.5	1140	7/8	3-1/8	1-1/8	6	2
KW4*115*HA	30	3	1.5	1140	7/8	3-1/8	1-3/8	8	3
KW4*145*HA	30	3	1.5	1140	1-1/8	3-1/8	1-3/8	8	3
KW4*182*HA	30	4	1.5	1140	1-1/8	3-1/8	1-3/8	10	4

Model Number KW*E/G/H/ K/L/T	Unit Dimensions (Inches)			Approx. Unit Wt. (Lbs.)
	L	W	H	

6 FPI

KW6*036*HA	59-7/8	27-3/8	49-1/4	303
KW6*047*HA	59-7/8	27-3/8	49-1/4	303
KW6*059*HA	59-7/8	27-3/8	49-1/4	303
KW6*072*HA	99-7/8	27-3/8	49-1/4	509
KW6*096*HA	99-7/8	27-3/8	49-1/4	509
KW6*120*HA	99-7/8	27-3/8	49-1/4	509
KW6*143*HA	139-7/8	27-3/8	49-1/4	682
KW6*179*HA	139-7/8	27-3/8	49-1/4	682
KW6*216*HA	179-7/8	27-3/8	49-1/4	1,050

4 FPI

KW4*038*HA	59-7/8	27-3/8	49-1/4	303
KW4*048*HA	59-7/8	27-3/8	49-1/4	303
KW4*077*HA	99-7/8	27-3/8	49-1/4	509
KW4*097*HA	99-7/8	27-3/8	49-1/4	509
KW4*115*HA	139-7/8	27-3/8	49-1/4	682
KW4*145*HA	139-7/8	27-3/8	49-1/4	682
KW4*182*HA	179-7/8	27-3/8	49-1/4	1,050

* Each asterisk represents a variable character based on defrost and motor ordered. See page 4 for nomenclature.

[^] For units with mounted TXV components. See Nozzle/ TXV table for distributor connection size when TXV is field installed.

1. For dimensional distance between hanger slots, consult model's corresponding dimension drawing. Hanger slots are 1" deep x 1/2" wide.
2. Drain is 1-1/4" NPT for all models.
3. For shipping dimensions and weights, see Shipping Information table on page 19.

Physical Dimensions

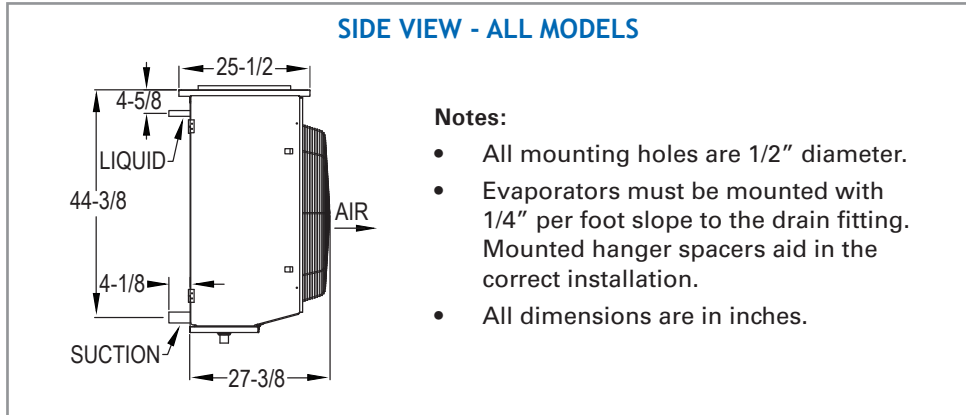

FIGURE 1 - SINGLE FAN

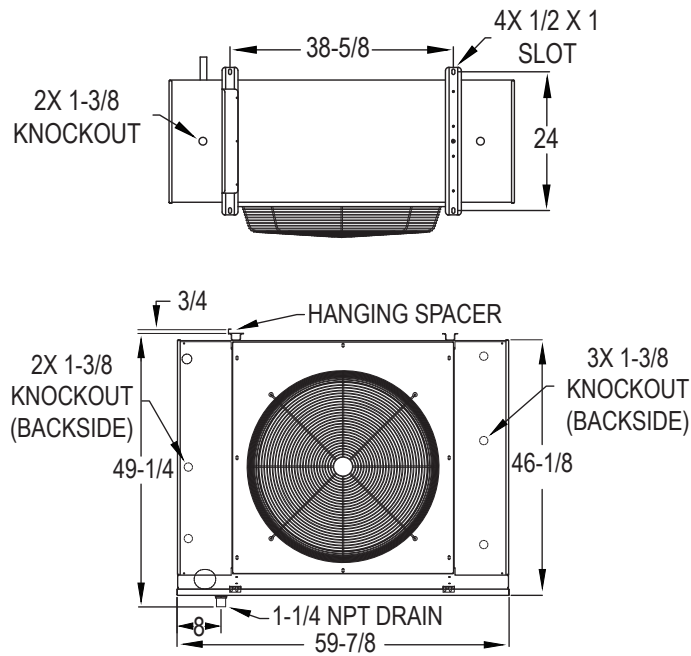
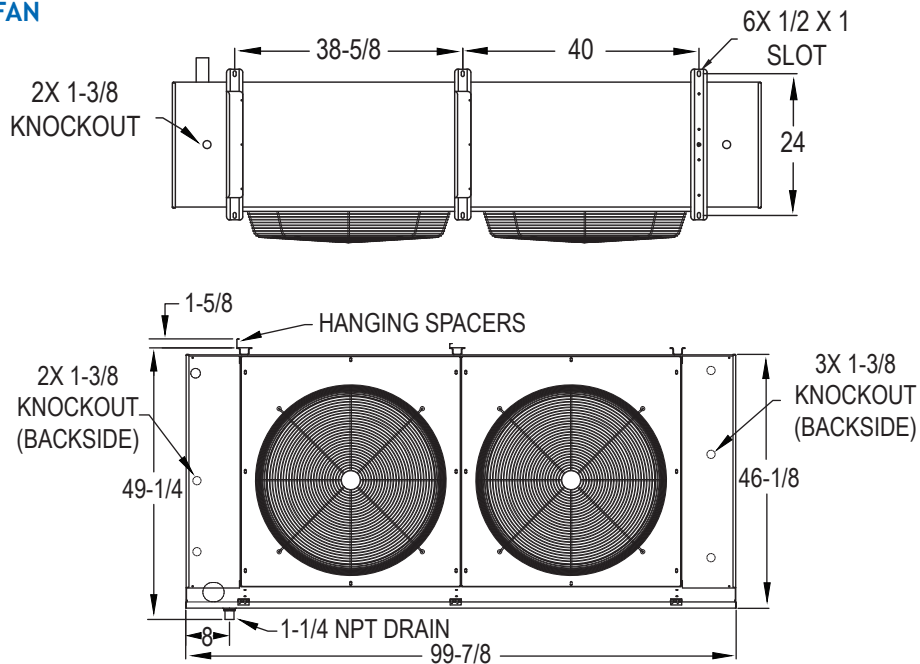

FIGURE 2 - TWO FAN



Physical Dimensions

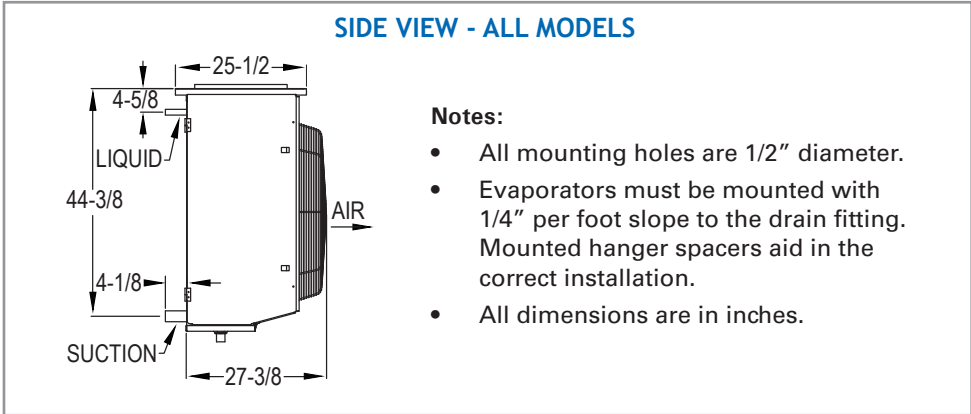

FIGURE 3 - THREE FAN

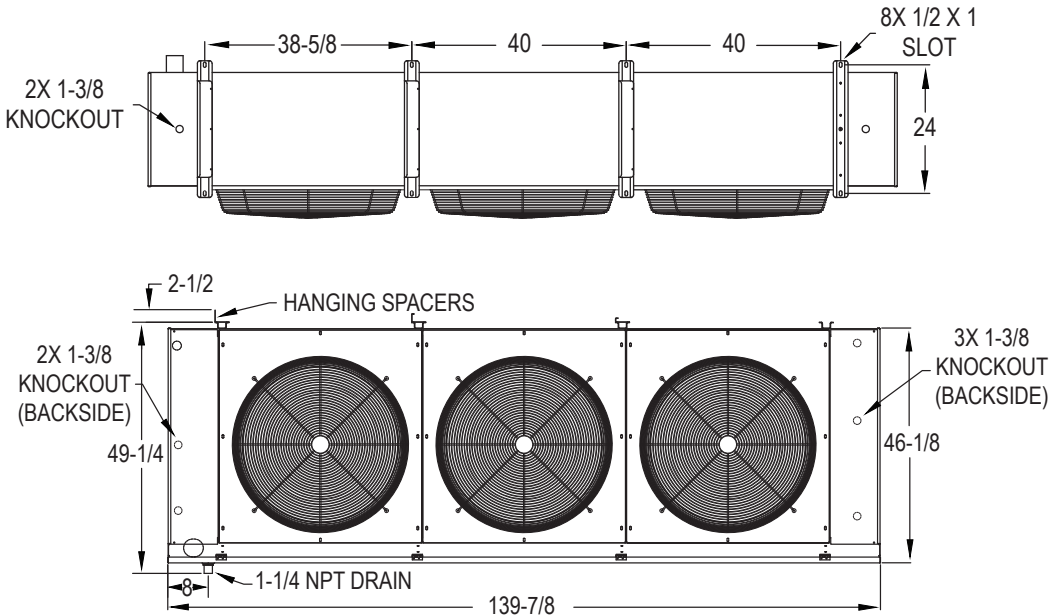
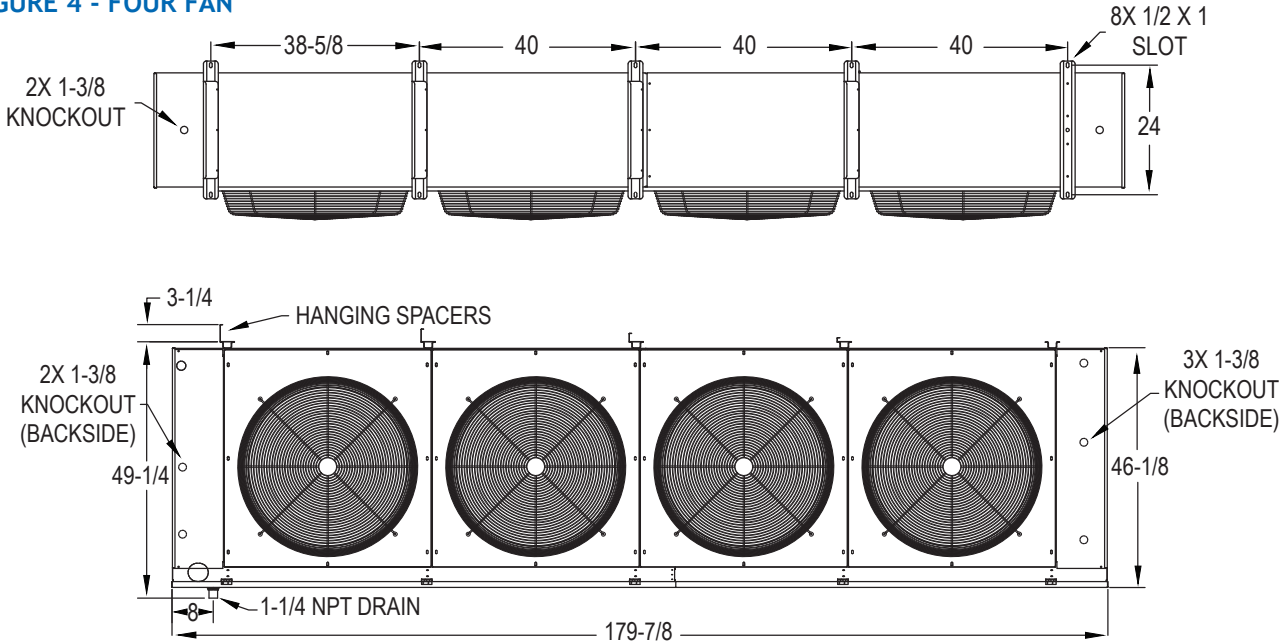

FIGURE 4 - FOUR FAN



Due to continuing product development, specifications are subject to change without notice.