



PACKAGED REFRIGERATION SYSTEM



Walk-Ins: Small to Medium Cooler and Freezer Applications

Medium Temperature

4,790 to 15,830 BTUH

Low Temperature

3,790 to 15,130 BTUH



FEATURES

The Packaged Refrigeration System's innovative design is a DOE AWEF rated self-contained system that comes in two sizes to satisfy low and medium temperature refrigeration needs - ideal for holding applications. We strive to incorporate sustainable solutions along with options and functionality that satisfy regulatory compliance. The PRS is EcoNet Enabled with Electronic Expansion Valve and can be operated with an optional Command Center from anywhere.

SIZES

Available in 8 scroll compressor + 2 hermetic compressor models



HIGHLIGHTS

- EcoNet Enabled to maximize energy efficiency with less compressor runtime
- EcoNet optimizes defrost by using adaptive defrost or managing compressor runtime
- EcoNet improves product quality by reducing temperature fluctuation
- Available outdoor options include a Roof Kit and Hail Guard
- Factory pre-charged with R-448A
- One electrical wiring point with the ability to add a plug on select models
- Standard boil-out pan with an option to mount a drain line
- Lift-off panels & large electrical box

BTUH

- Medium Temperature
4,790 to 15,830
- Low Temperature
3,790 to 15,130

MODEL NOMENCLATURE

H	P	H	050	M	48	A	B
HTPG	Product	Compressor	Horsepower	Temperature	Refrigerant	Voltage	Vintage
	Packaged Refrigeration System	H = Hermetic O = Scroll		M = Medium L = Low D = Medium Electric Defrost	48 = R-448A	A = 115/1/60 D = 208-230/1/60	B

OPTIONAL ECONET® COMMAND CENTER

Using Rheem's SMART technology, the EcoNet Command Center can program, monitor, and troubleshoot equipment outside of the space being cooled. The Packaged Refrigeration System is already assembled with the EcoNet Control Board which analyzes and optimizes defrost cycles to provide a consistent temperature and extend the life of the unit.

By adding the optional Command Center, a Technician or Building Manager never has to step foot into the freezer in order to change the temperature or maintain the equipment. Control up to 32 devices (including the Command Center) on one touchscreen.

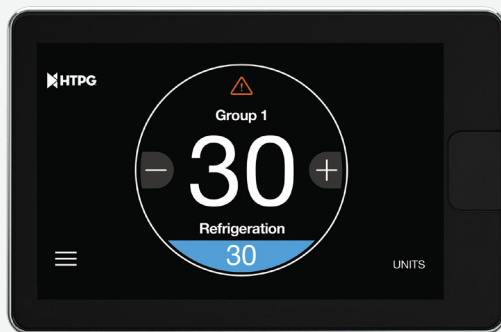

EcoNet® Command Center

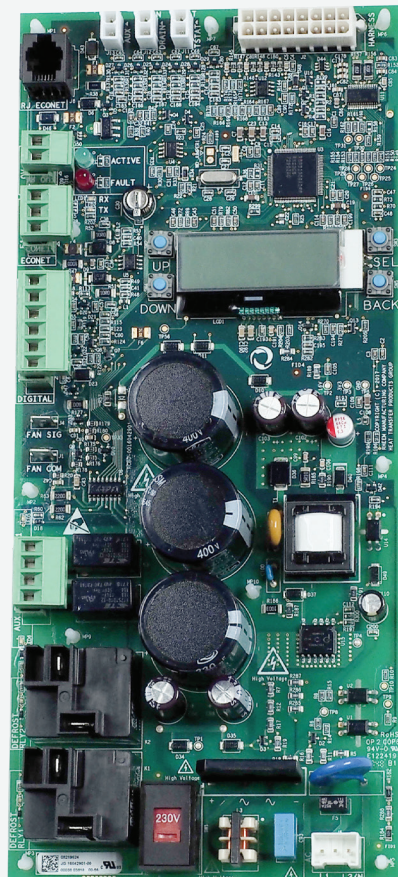

Control Board

DEFROST CAPACITIES

AIR DEFROST // MEDIUM TEMPERATURE

Model No.	Ambient Temperature									
	80°		90°		95°		100°		110°	
	Box Temperature									
	35°F	38°F	35°F	38°F	35°F	38°F	35°F	38°F	35°F	38°F
HPH050M48*B	5,960	6,290	5,550	5,870	5,360	5,670	5,170	5,470	4,790	5,090
HPH055M48*B	6,480	6,870	6,040	6,400	5,830	6,170	5,610	5,950	5,170	5,490
HPO080M48*B	8,200	8,600	7,750	8,120	7,530	7,890	7,310	7,660	6,850	7,180
HPO100M48*B	9,290	9,820	8,790	9,260	8,530	9,000	8,260	8,740	7,730	8,180
HPO120M48*B	11,900	12,480	11,250	11,800	10,910	11,460	10,590	11,110	9,870	10,390
HPO150M48*B	15,110	15,830	14,280	14,940	13,840	14,510	13,350	14,030	12,410	13,010

ELECTRIC DEFROST // MEDIUM TEMPERATURE

Model No.	Ambient Temperature									
	80°		90°		95°		100°		110°	
	Box Temperature									
	35°F	38°F	35°F	38°F	35°F	38°F	35°F	38°F	35°F	38°F
HPH050D48DB	5,960	6,290	5,550	5,870	5,360	5,670	5,170	5,470	4,790	5,090
HPH055D48DB	6,480	6,870	6,040	6,400	5,830	6,170	5,610	5,950	5,170	5,490
HPO080D48DB	8,200	8,600	7,750	8,120	7,530	7,890	7,310	7,660	6,850	7,180
HPO100D48DB	9,290	9,820	8,790	9,260	8,530	9,000	8,260	8,740	7,730	8,180
HPO120D48DB	11,900	12,480	11,250	11,800	10,910	11,460	10,590	11,110	9,870	10,390
HPO150D48DB	15,110	15,830	14,280	14,940	13,840	14,510	13,350	14,030	12,410	13,010

DEFROST CAPACITIES

ELECTRIC DEFROST // LOW TEMPERATURE

Model No.	Ambient Temperature								
	80°			90°			95°		
	Box Temperature								
	0°F	-10°F	-20°F	0°F	-10°F	-20°F	0°F	-10°F	-20°F
HPO150L48DB	7,030	5,790	4,630	6,640	5,460	4,360	6,440	5,290	4,210
HPO250L48DB	9,770	8,230	6,830	9,210	7,770	6,440	8,930	7,520	6,240
HPO300L48DB	13,550	11,340	9,340	12,810	10,730	8,830	12,440	10,400	8,570
HPO350L48DB	15,130	12,740	10,680	14,090	11,950	10,050	13,770	11,650	9,750

Model No.	100°			110°		
	0°F	-10°F	-20°F	0°F	-10°F	-20°F
HPO150L48DB	6,230	5,110	4,070	5,810	4,650	3,790
HPO250L48DB	8,630	7,280	6,040	8,030	6,770	5,650
HPO300L48DB	12,040	10,070	8,290	11,210	9,370	7,720
HPO350L48DB	13,310	11,300	9,430	12,320	10,540	8,810

OUTDOOR OPTIONS

- *Hail Guard*
- *Roof Kit*

NOTES:

* Asterisk represents a variable in the model nomenclature.

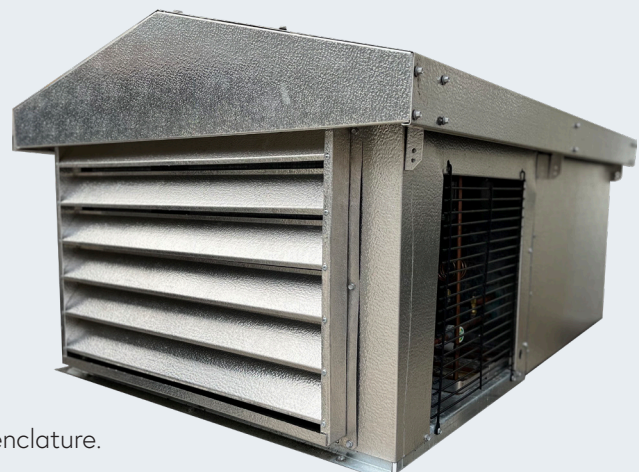

ELECTRICAL DATA

AIR DEFROST // MEDIUM TEMPERATURE

*U.C. CFM = Unit Cooler Cubic Feet Per Minute

Model No.	Voltage	MCA	MOPD	Unit Amps	U.C. CFM	NEMA Receptacle
HPH050M48AB	115/1/60	15	20	10.5	600	5-20R
HPH055M48AB	115/1/60	15	20	11.8	600	5-20R
HPO080M48AB	115/1/60	18.4	30	15.1	600	5-20R
HPO100M48AB	115/1/60	20	30	16.4	600	-
HPO120M48AB	115/1/60	21.7	35	18.1	1200	-
HPH050M48DB	208-230/1/60	15	15	6.6	600	6-15R
HPH055M48DB	208-230/1/60	15	15	6.7	600	6-15R
HPO080M48DB	208-230/1/60	15	15	7.4	600	6-15R
HPO100M48DB	208-230/1/60	15	15	7.6	600	6-15R
HPO120M48DB	208-230/1/60	15	15	10.2	1200	6-15R
HPO150M48DB	208-230/1/60	17.2	25	14.3	1200	6-20R

ELECTRIC DEFROST // MEDIUM TEMPERATURE

Model No.	Voltage	MCA	MOPD	Unit Amps	U.C. CFM	NEMA Receptacle
HPH050D48DB	208-230/1/60	15	15	8.3	600	6-15R
HPH055D48DB	208-230/1/60	15	15	8.3	600	6-15R
HPO080D48DB	208-230/1/60	15	15	8.3	600	6-15R
HPO100D48DB	208-230/1/60	15	15	8.3	600	6-15R
HPO120D48DB	208-230/1/60	15	15	10.2	1200	6-15R
HPO150D48DB	208-230/1/60	17.2	25	14.3	1200	6-20R

ELECTRIC DEFROST // LOW TEMPERATURE

Model No.	Voltage	MCA	MOPD	Unit Amps	U.C. CFM	NEMA Receptacle
HPO150L48DB	208-230/1/60	15	15	9.8	600	6-15R
HPO250L48DB	208-230/1/60	17.5	25	14.4	600	6-20R
HPO300L48DB	208-230/1/60	19	30	15.8	1200	-
HPO350L48DB	208-230/1/60	23.4	35	19.3	1200	-

SIZE & WEIGHT

AIR DEFROST // MEDIUM TEMPERATURE

Model No.	Cabinet Size	Approx. NET Weight - LB	Approx. NET Weight - KG	Approx. SHIP Weight - LB	Approx. SHIP Weight - KG	NEMA Receptacle
HPH050M48AB	Small	206	93.4	286	129.7	5-20R
HPH055M48AB	Small	206	93.4	286	129.7	5-20R
HPO080M48AB	Small	206	93.4	286	129.7	5-20R
HPO100M48AB	Small	206	93.4	286	129.7	-
HPO120M48AB	Large	235	106.6	313	142	-
HPH050M48DB	Small	206	93.4	286	129.7	6-15R
HPH055M48DB	Small	206	93.4	286	129.7	6-15R
HPO080M48DB	Small	206	93.4	286	129.7	6-15R
HPO100M48DB	Small	206	93.4	286	129.7	6-15R
HPO120M48DB	Large	235	106.6	313	142	6-15R
HPO150M48DB	Large	235	106.6	313	142	6-20R

ELECTRIC DEFROST // MEDIUM TEMPERATURE

Model No.	Cabinet Size	Approx. NET Weight - LB	Approx. NET Weight - KG	Approx. SHIP Weight - LB	Approx. SHIP Weight - KG	NEMA Receptacle
HPH050D48DB	Small	206	93.4	286	129.7	6-15R
HPH055D48DB	Small	206	93.4	286	129.7	6-15R
HPO080D48DB	Small	206	93.4	286	129.7	6-15R
HPO100D48DB	Small	206	93.4	286	129.7	6-15R
HPO120D48DB	Large	235	106.6	313	142	6-15R
HPO150D48DB	Large	235	106.6	313	142	6-20R

ELECTRIC DEFROST // LOW TEMPERATURE

Model No.	Cabinet Size	Approx. NET Weight - LB	Approx. NET Weight - KG	Approx. SHIP Weight - LB	Approx. SHIP Weight - KG	NEMA Receptacle
HPO150L48DB	Small	218.5	99.1	298.5	135.4	6-15R
HPO250L48DB	Small	218.5	99.1	298.5	135.4	6-20R
HPO300L48DB	Large	264	119.7	342	155.1	-
HPO350L48DB	Large	264	119.7	342	155.1	-

CABINET DIMENSIONS

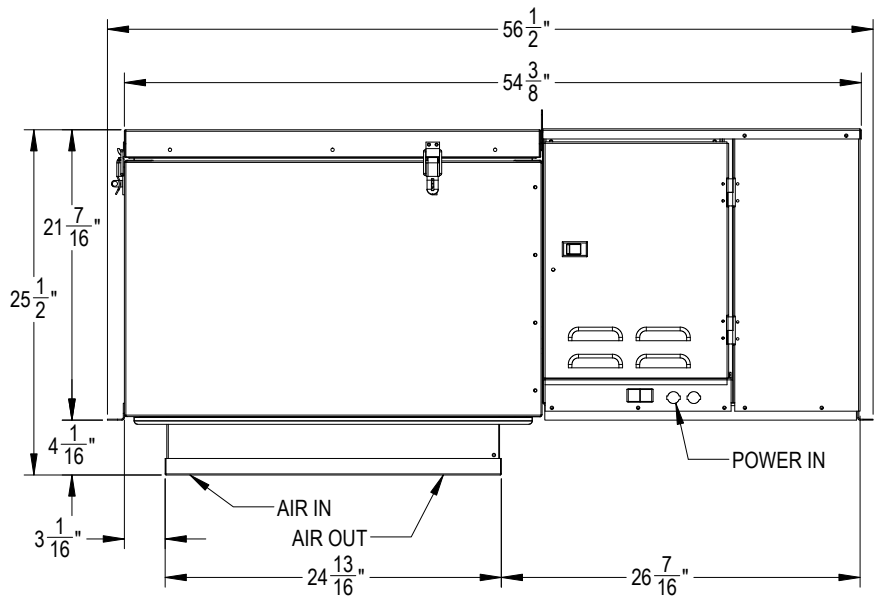
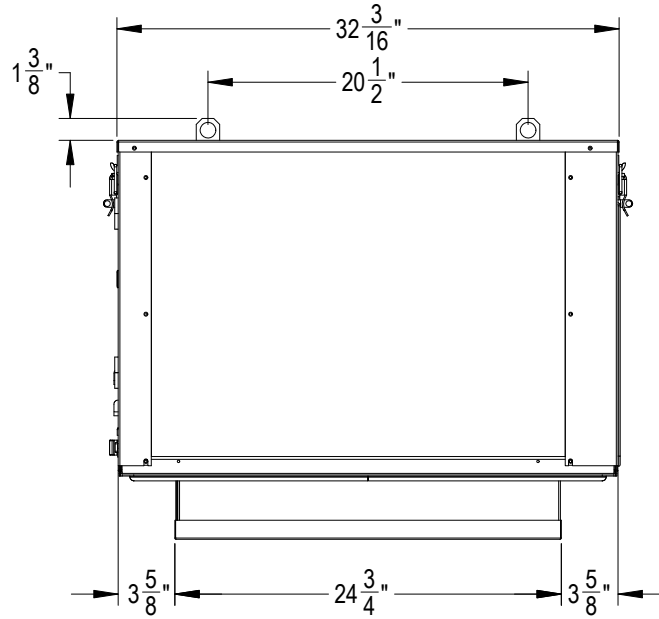
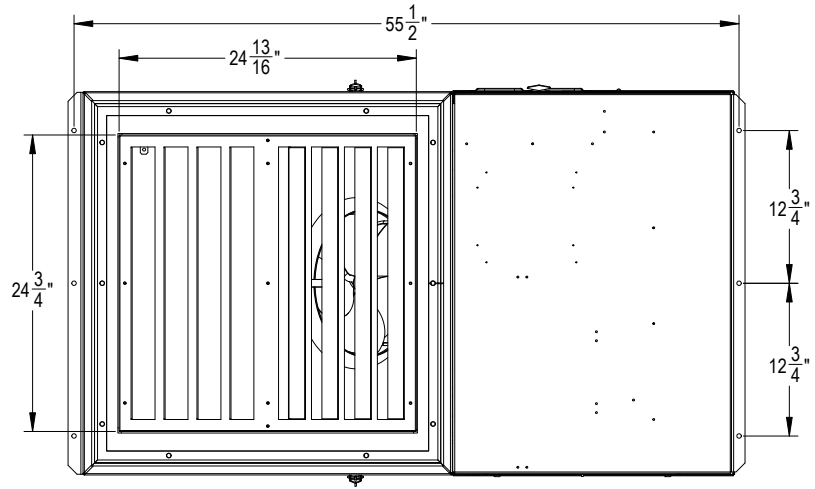

SMALLS

CABINET DIMENSIONS

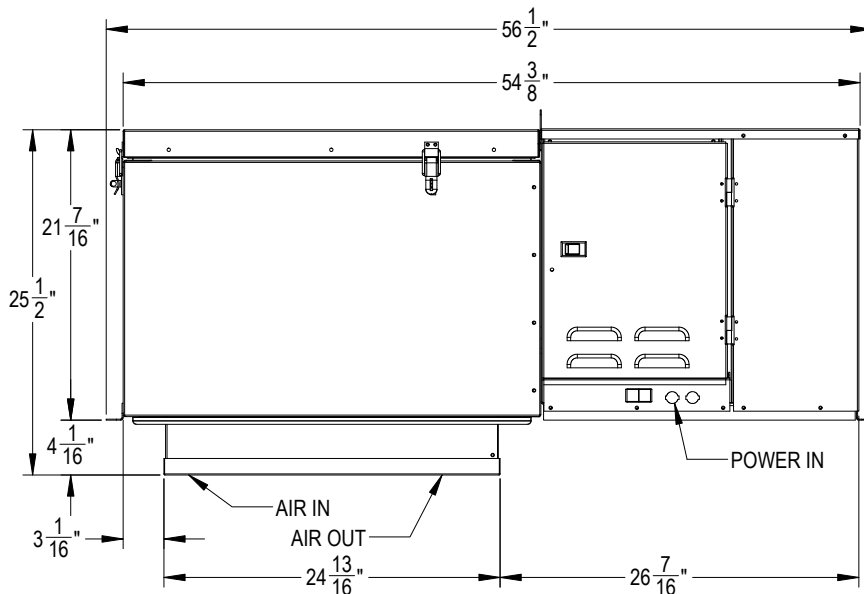
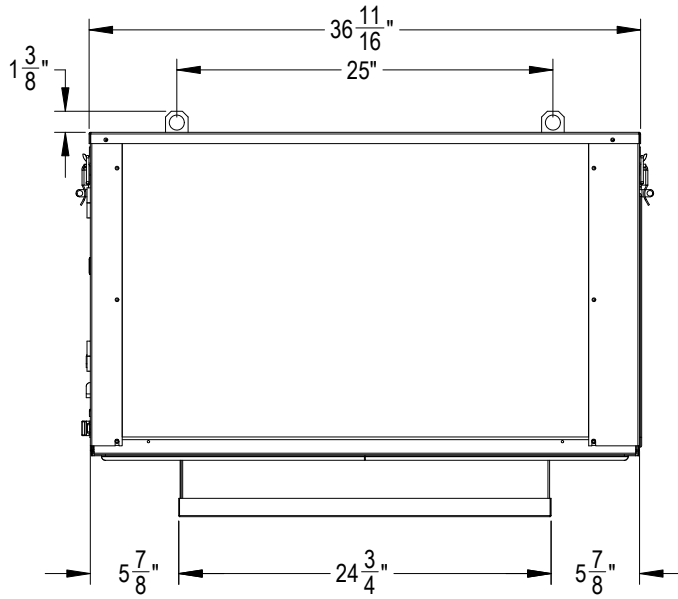
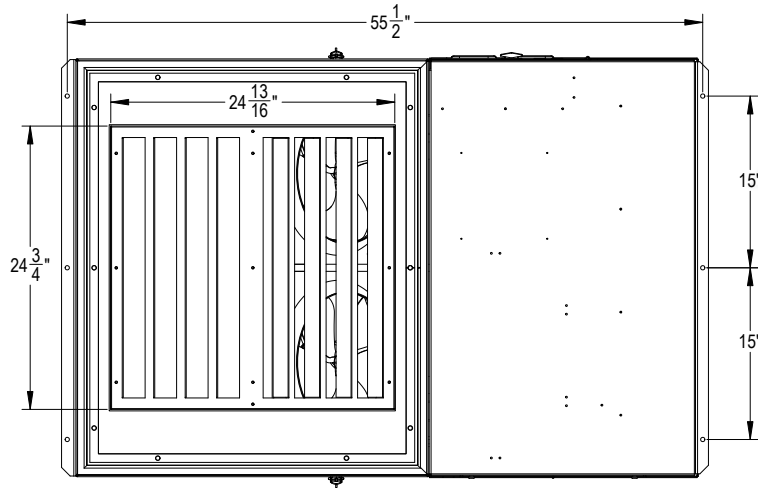

WE
G
R
A
L

AWEF DATA

AIR DEFROST

Model No.	Indoor	Outdoor	Temperature
HPH050M48AB	5.61	7.6	Medium
HPH055M48AB			
HPO080M48AB			
HPO100M48AB			
HPO120M48AB			
HPH050M48DB			
HPH055M48DB			
HPO080M48DB			
HPO100M48DB			
HPO120M48DB			
HPO150M48DB			

ELECTRIC DEFROST

Model No.	Indoor	Outdoor	Temperature
HPH050D48DB	5.61	7.6	Medium
HPH055D48DB			
HPO080D48DB			
HPO100D48DB			
HPO120D48DB			
HPO150D48DB			

ELECTRIC DEFROST

Model No.	Indoor	Outdoor	Temperature
HPO150L48DB	2.17	3.15	Low
HPO250L48DB			
HPO300L48DB			
HPO350L48DB			

NOTES

* AWEF
(Annual Walk-in Energy Factor)

- If the Medium Temperature model has a numerical value in the table above, the following statement applies: "This refrigeration system is designed and certified for use in walk-in cooler applications"
- If the Low Temperature model has a numerical value in the table above, the following statement applies: "This refrigeration system is designed and certified"

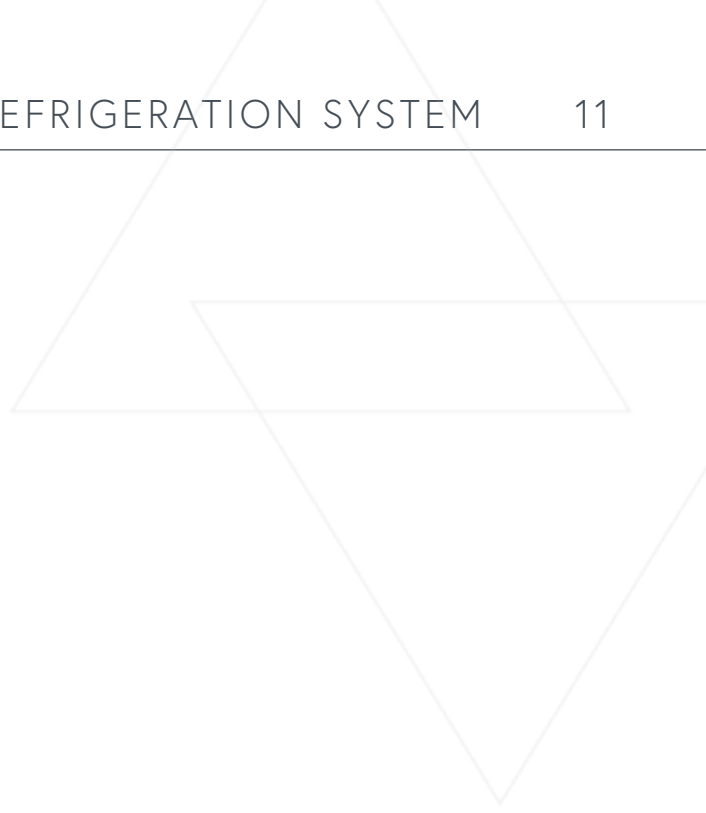

KRAMER

ENGINEERED FOR COOL.™

©2024 Heat Transfer Products Group

Published September 2024

KM_PRS_0924

kramer.htpg.com

This information is the most current and accurate information available and is subject to change without notice. HTPG makes no warranty or guarantee of any kind, express or implied, regarding the information set forth herein, including without limitation warranty regarding its currency, accuracy or completeness or any warranty of merchantability or fitness for a particular purpose.

