

INSTALLATION OPERATION AND MAINTENANCE INSTRUCTIONS

IOM 111

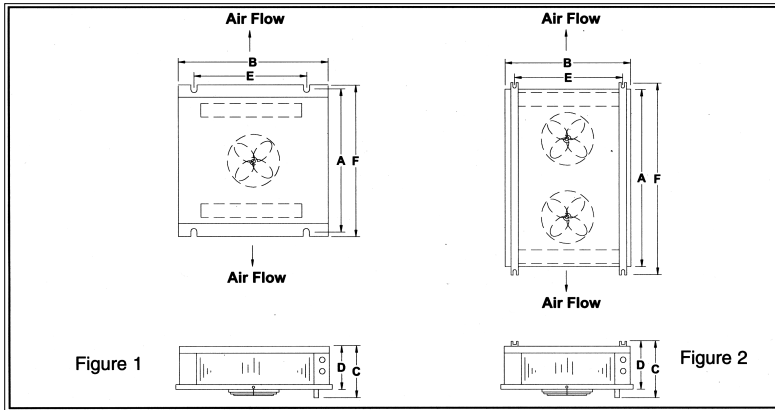

MODEL NUMBER	FIG.	DIMENSIONS (In)						CONNECTION SIZE (In)			SHIP WT. (lbs)
		A	B	C	D	E	F	SUCTION	INLET	DRAIN	
TW 17-9	1	18-1/2	16-1/2	7-5/8	5-7/8	12-1/2	19	1/2 MF	1/2 FN	1/2 OD	17
TW 17-12	1	18-1/2	16-1/2	7-5/8	5-7/8	12-1/2	19	1/2 MF	1/2 FN	1/2 OD	19
TW 17-18	1	18-1/2	16-1/2	9-1/8	7-3/8	12-1/2	19	1/2 MF	1/2 FN	1/2 OD	23
TW 17-25	1	20-1/2	18-1/2	9-5/8	7-3/8	15	21	1/2 MF	1/2 FN	1/2 OD	26
TW 17-35	1	20-1/2	18-1/2	11-1/4	9	15	21	1/2 MF	1/2 FN	1/2 OD	28
TW 17-45	1	30-1/2	21-1/4	10	7-3/4	17	32	5/8 OD	1/2 OD	1/2 FPT	44
TW 17-55	1	30-1/2	21-1/4	12	9-3/4	17	32	5/8 OD	1/2 OD	1/2 FPT	50
TW 18-65	1	30-1/2	21-1/4	12	9-3/4	17	32	5/8 OD	1/2 OD	1/2 FPT	55
TW 17-75	2	35-1/4	36-1/4	11	7-3/4	31	36-1/2	5/8 OD	1/2 OD	1/2 FPT	109
TW 18-85	2	35-1/4	36-1/4	11	7-3/4	31	36-1/2	5/8 OD	1/2 OD	1/2 FPT	115
TW 17-105	2	35-1/4	36-1/4	13	9-3/4	31	36-1/2	7/8 OD	5/8 OD	1/2 FPT	121
TW 18-120	2	35-1/4	36-1/4	13	9-3/4	31	36-1/2	7/8 OD	5/8 OD	1/2 FPT	128

GENERAL

RECEIPT AND EXAMINATION

Carefully check all items against bill of lading to be sure everything has been received as ordered. Carefully inspect all items for damage and, if any is found, report it immediately to the carrier and file damage claim with same.

INSTALLATION

LOCATION AND MOUNTING

The TW is designed to mount on the ceiling only. The unit should be installed so that there are no restrictions on the air inlet or outlet as this will cause the refrigeration system to operate less efficiently.

Remove the unit from the carton. Using the fastener holes in the unit as a guide, locate the mounting fasteners in the ceiling of the walk-in or reach-in freezer. Use #10 screws or 1/4" diameter bolts to secure the unit to the ceiling. The unit must be installed so as to allow drainage of condensate coming off the coil.

The National Sanitation Foundation (NSF) requires that any flush mounted unit be properly and completely sealed, with an approved NSF sealant, between the unit and the mounting surface.

ELECTRICAL

System electrical installation should conform to all applicable codes and practices. All models will require the connection of power to the fan motor according to the nameplate motor circuit electrical ratings.

REPLACEMENT PARTS

To order replacement parts, contact your local representative or contact the factory (800) 288-9488 for the location of the nearest HTP wholesaler. Always provide the evaporator model number, serial number, unit voltage and a complete description of the part required.

Coil Model Number	FAN MOTOR			FAN BLADE			FAN GUARD		DRAIN PAN
	MOTOR HP	MOTOR RPM	PART NUMBER	BORE	DESCRIPTION	PART NUMBER	DIA.	PART NUMBER	PART NUMBER
TW 17-9	4 Watt	1550	103104002	Hubless	820 CCW	204395008	8"	206569000	208701
TW 17-12	4 Watt	1550	103104002	Hubless	820 CCW	204395008	8"	206569000	208701
TW 17-18	9 Watt	1550	103104004	Hubless	831 CCW	204395010	8"	206569000	208701
TW 17-25	9 Watt	1550	103104004	Hubless	1020 CCW	204395016	10"	201006002	208735
TW 17-35	9 Watt	1550	103104004	Hubless	1020 CCW	204395016	10"	201006002	208735
TW 17-45	1/20	1550	102540001	5/16	1218 CCW	214118000	12"	201006003	208746
TW 17-55	1/20	1550	102540001	5/16	1219 CCW	11860	12"	201006003	208746
TW 18-65	1/20	1550	102540001	5/16	1223 CCW	11882	12"	201006004	208746
TW 17-75	1/12	1550	102540001	1/2	1616 CCW	11904	16"	201006004	105744
TW 18-85	1/12	1550	102540001	1/2	1616 CCW	11904	16"	201006004	105744
TW 17-105	1/12	1550	102540001	1/2	1616 CCW	11904	16"	201006004	105744
TW 18-120	1/12	1550	102540001	1/2	1616 CCW	11904	16"	201006004	105744