



*Russell*

# MULTICON INSTALLATION AND MAINTENANCE MANUAL

Bulletin No. IOM 400.0  
November 1993

## AIR COOLED CONDENSERS MODELS CAC, RAC, VAC, & VEQ



*Russell*

221 S. Berry St., CA 92821 Tel (714) 529-1935 FAX (714) 529-7203

## GENERAL SAFETY INFORMATION

- Installation and maintenance are to be performed only by qualified personnel who are familiar with type of equipment.
- Make sure that all field wiring conforms to the requirements of the equipment and all applicable national and local codes.
- Avoid contact with sharp edges and coil surfaces. They are a potential injury hazard.
- Make sure all power sources are disconnected before any service work is done on the units.

## INSPECTION

Check all items against the bill of lading to make sure all crates and cartons have been received. If there is any damage, report it immediately to the carrier and file a claim. Make sure the voltage on the unit nameplate agrees with the power supply available.

## RIGGING AND HANDLING

All Russell CAC and VAC 5 thru 19 model condensers are shipped on their sides with the exception of the smaller RAC models and larger VAC and VEQ models. All units come shipped on a skid with a wooden skeleton frame to prevent damage in transit. Leave all framing attached until the unit is as close as possible to its final installed location.

All units have built in lifting lugs, see figure 1 (below) for recommended rigging procedure and lifting procedures. Use spreader bar(s) when necessary, failure to do so will damage the air cooled condenser. Never use the coil headers or return bends for moving or lifting the condenser.

## UNIT LOCATION

Do not locate any unit so as to be bordered by tall obstructions on three or more sides. See figure 2 for minimum clearance from obstructions and between units. Short circuiting of the air flow or the intake of warmer air from another unit will seriously degrade the

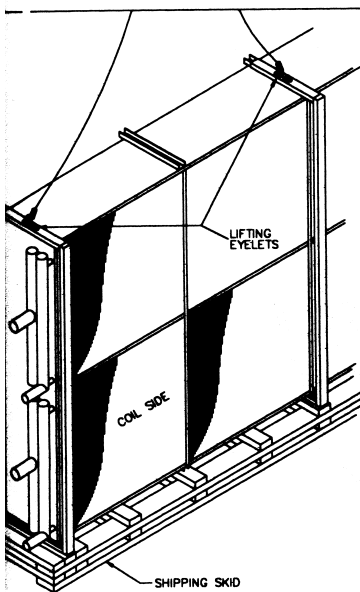

- A. REMOVE FROM SKID**
1. LOOSEN CONDENSER FROM SHIPPING SKID.
  2. LIFT CONDENSER OFF OF SKID BY HOOKING INTO LIFTING EYELETS (DOUBLE SLOT'S) AT EACH POSITION WHERE THERE IS A LEG.
  3. SET ON GROUND.

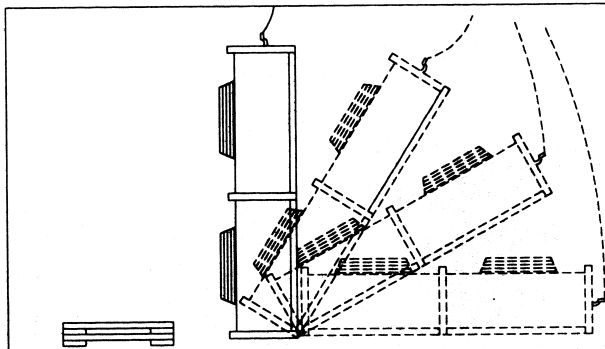

- B. ROTATE UNIT FLAT**
1. GENTLY PULL TOP OF UNIT OVER, MAINTAINING CABLE TENSION AS UNIT IS ROTATED FROM VERTICAL TO HORIZONTAL POSITION.

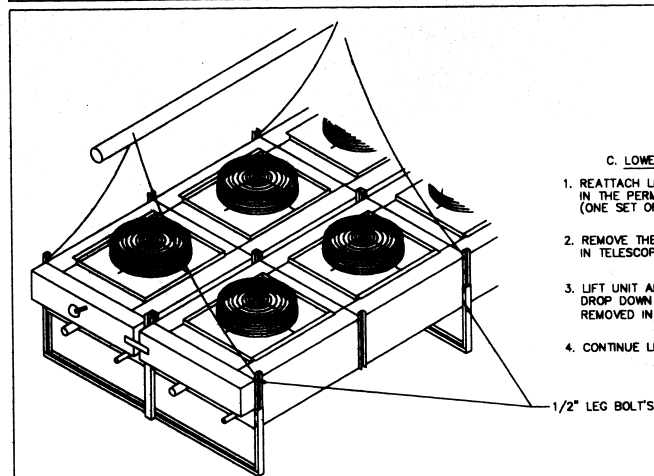

- C. LOWERING LEGS INTO POSITION**
1. REATTACH LIFTING HOOKS INTO LIFTING EYES IN THE PERMANENTLY ATTACHED LEG CHANNELS. (ONE SET OF HOOKS AT EACH LEG POSITION)
  2. REMOVE THE FOUR 1/2" BOLTS THAT HOLD EACH LEG IN TELESCOPED POSITION.
  3. LIFT UNIT ABOUT 18" SO THAT EACH LEG CAN DROP DOWN AND BE REATTACHED WITH THE FOUR BOLTS REMOVED IN STEP 2. TIGHTEN BOLTS SECURELY.
  4. CONTINUE LIFTING UNIT TO ITS NEW HOME.

performance of the air cooled condenser. Noise consideration should also be considered when locating an air cooled condenser. Proximity to windows, walls, and surrounding structures can cause objections by the occupants. An acoustical expert should be consulted when noise is of a particular concern.

Structural supports and roof or platforms should be sufficiently strong to support the condensers operating weight. Consult with a professional structural engineer to determine safe platform loading.

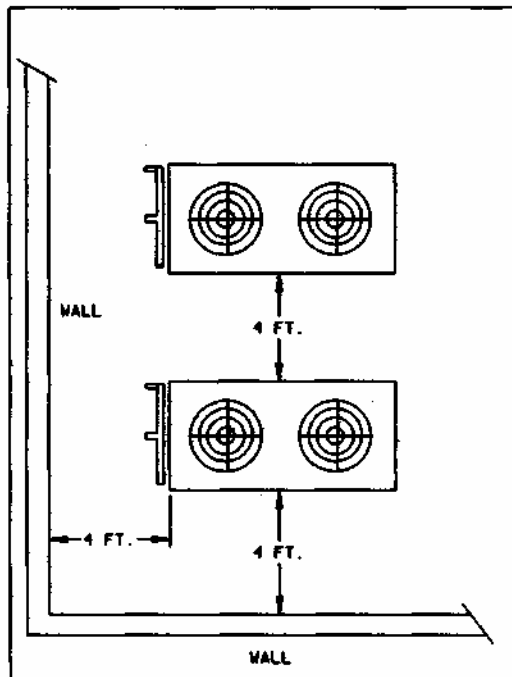

FIGURE 2: MINI. CLEARANCES  
PLAN VIEW

## REFRIGERANT PIPING

All piping should be done in accord with "The Safety Code for Mechanical Refrigeration" (ANSI/ASHRAE15-1992) and "The Code for Pressure Piping" (ANSI B31.1) as well as all applicable local and national codes.

Units are available in both single and double width fan versions. The double width fan models have two coils that may be used as independent condensers, or may be field coupled in parallel to perform as one condenser. Factory fabricated manifold saddles are available as an optional feature.

- Refrigerant lines should be selected from the tables on pages 25 and 26 of the Russell Refrigeration Engineering Manual. Lines should never be selected on the basis of the inlet and outlet fitting sizes on the condenser.

If pull down loads, much greater than design loads, are encountered, both discharge and liquid lines should be sized for the pull down BTUH load.

Gas velocities provided by the fine size selection tables are adequate for oil return in either horizontal runs or vertical risers.

To ensure proper oil return follow these two steps:

- Pitch horizontal runs in the direction of flow 1/4 inch per foot.
- Provide traps at the bottom of each riser and every 15 feet up the riser. These traps should be formed of short sweep street ells.

All refrigerant piping must be well supported so that line vibration or expansion and contraction forces are not imposed on the condenser piping connections. **All piping connected to the condenser must be supported as close to the condenser as possible, especially when the circuit is a single tube connection leading out of the condenser core as typically seen on multiple circuit units. Never handle the condenser or use any of the piping headers or connections as a support or lifting point.**

- A high pitched noise seeming to come from the condenser or discharge line with accompanying line vibration comes from compressor pulsation. Install a discharge line orifice (if available from the compressor manufacturer) or a discharge line muffler at the compressor.
- Reduced loads by capacity reduction may require special piping arrangement not covered by this document. For these situations consult your engineer, or ASHRAE Refrigeration Manual.

- Use double risers only where specifically required by specifications.
- The use of an oil separator of adequate size tends to minimize oil return problems and compressor pulsation problems. When oil separators are used with condensers, a discharge line check valve at the oil separator outlet must be employed.
- Install the refrigerant sight glass immediately at the receiver outlet. If a sight glass is required at the drier outlet, a second sight glass should be used. If a long liquid line run or substantial liquid line rise is required, it may be advisable to install a sight glass in the liquid line at the expansion valve inlet. Only the sight glass at the receiver outlet should be used to determine if additional refrigerant must be added.
- Where multiple condensers are required, all condensers must be at the same level, and piped in parallel. Branches must be the same size and length.

## REFRIGERANT CHARGE

- Charging of a system should be carried out using visual reference to the refrigerant sight glass. Charging should be stopped when the sight glass becomes clear. Care must be taken when charging a system with a blended or near azeotropic refrigerant. If you are unfamiliar with the proper charging procedures, contact your refrigerant supplier for assistance.

## WIRING

- Single phase fan motors are used on models VAC 5 thru 19, and are pre-wired to provide the closest possible balance on three phase networks. Motors are available as, or can be re-wired for single phase network in the field. Contact the factory for instructions. All single phase motors are inherently protected.
- Where three phase motors are used on the larger model VAC and VEQ models, the motors are inherently protected. All three phase motors are dual voltage and can be quickly converted in the field by repositioning the voltage change device (VCD) located inside the motor.

**Always make sure that the voltage applied to the unit matches the voltage rating of the unit as indicated on the unit's nameplate.**

## START-UP

Prior to start-up check the following items:

1. Check fans for freedom of movement.
2. Check all fan blade set screws, motor mounts, and mounting leg fasteners.
3. Check that the nameplate voltage matches the power supply voltage.
4. Upon start-up check the rotation of all fans to insure that air is being discharged up out of the fan discharges. If discharge is wrong, correct by reversing 2 of the motor leads in the junction box.

## MAINTENANCE

Maintenance of the air cooled condenser is extremely important for extended life and peak performance. The following is a recommended maintenance schedule. Site conditions will dictate the frequency of this maintenance plan. The equipment warranty does not cover corrosion, misuse, or misapplication of the condenser.

1. Shut all power off to the air cooled condenser and refrigeration system at the closest disconnect switch and use a lock to prevent others from turning power back on to the unit.
2. Remove fan guards.
3. Remove all large debris (leaves, paper, cardboard, plastic film, etc.) from the top as well as beneath the unit. Keep the area clean around the condenser by removing loose debris around the air cooled condenser.
4. Inspect the unit for damaged fins caused by the debris. Comb out any bent fins with a fin comb. Inspect the unit for signs of corrosion. Note the area and amount of corrosion in your maintenance reports.
5. Should the heat transfer surface require cleaning use the following procedure. Use a cleaning solution that is compatible with the finned material and any protective

coating that may have been applied to the heat transfer surface. Follow the cleaning instructions exactly as described by the manufacturer of the cleaning agent. It is extremely important that a proper rinse be applied to the core once the cleaning process is completed. Use a hose with a spray wand and rinse from the top of the unit only. Do not rinse from the underside as this will not properly flush the cleaning agent from the core. Any residue of cleaner left for any extended period will begin to corrode the heat transfer surface. It is recommended to use a detergent type cleaner like Cal-Clean as a cleaning solution.

6. Inspect all fan and motor fasteners for tightness before installing the fan guards.

7. Turn power back on to the system.

**For inland installations (30 miles from any body of salt water):** Schedule visual inspection of the heat transfer surface and unit once every 6 months. Clean the heat transfer surface should it show signs of significant dirt accumulation. Recommended minimum cleaning cycle is once every 12 months.

**For sea coast installations (up to 30 miles from any body of salt water):** Schedule visual inspections of the heat transfer surface and unit once every 3 months. Clean the heat transfer surface thoroughly every 3 to 6 months with water to remove accumulated layers of salt. Every 12 months clean the heat transfer surface with an approved cleaning solution.

## WIRING DIAGRAMS

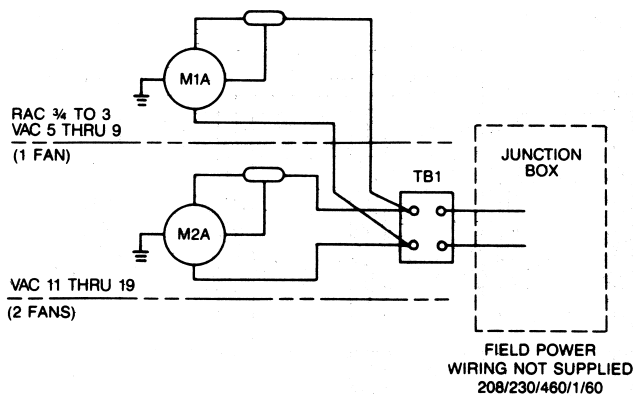

FIGURE 3: VAC 5 THRU 19 single phase wiring without fan cycling control.

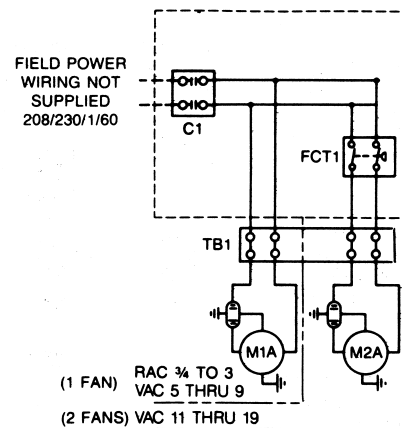

FIGURE 4: VAC 5 THRU 19 single phase wiring with fan cycling control.

# Wiring Diagram continues

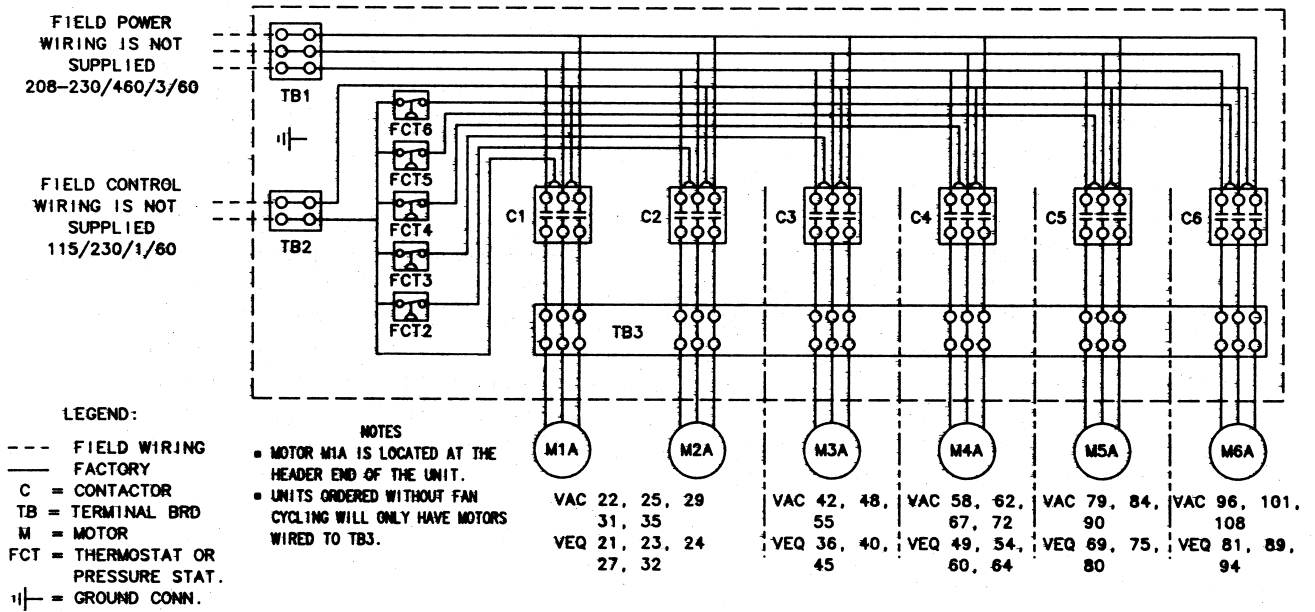

FIGURE 5: VAC and VEQ 3 phase wiring diagram for single row fan models with fan control.

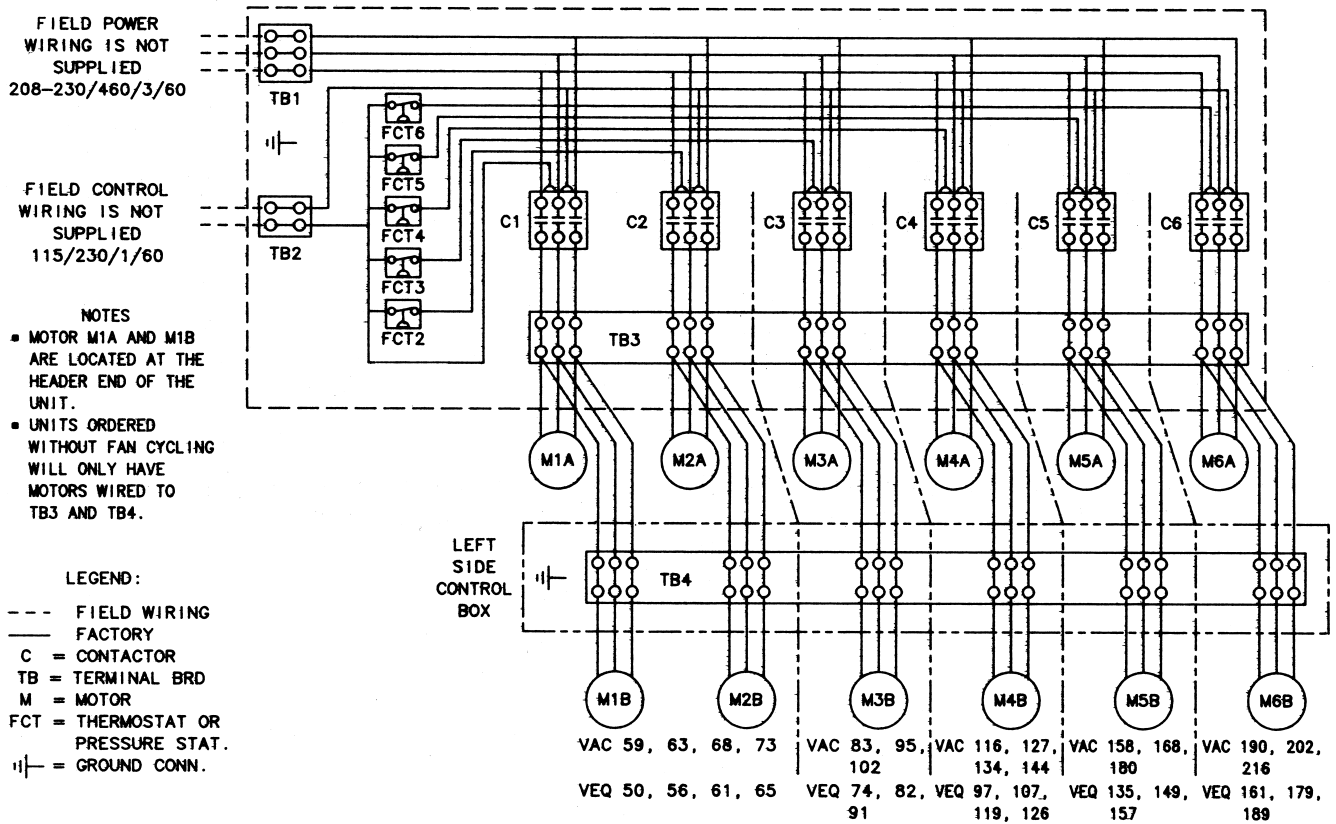

FIGURE 6: VAC and VEQ 3 phase wiring diagram for double row fan models with fan control.

# Refrigerant Charge

## REFRIGERANT CHARGE

The summer design refrigerant charge necessary for effective system operation is the sum of operating charge for the evaporator, refrigerant piping (suction, liquid and discharge lines), condenser and receiver. The pump-down capacity of the receiver should be somewhat greater (10% to 15%) than the total refrigerant charge required. When using the Russell low ambient control system, additional refrigerant, over and above the summer design system charge, must be added to the system to allow for condenser flooding. The amount of this added charge is determined by the ambient in which the condenser will operate. Table 9 lists the total unit charge for all Russell single systems. For calculating the refrigerant charge for each compressor system or condenser follow the example below:

### Given:

VAC-55 (3 fans long)  
 Design TD: 20°F  
 Flooded control, no fan cycling  
 R-22  
 Minimum design ambient 40°F

### Solution:

1. Select the total charge from Table 9 for a VAC-55 condenser, using R-22 refrigerant.
2. Select the appropriate correction factor from Table 10 for the ambient temperature range at time of charging.
3. Use Equation (9) to calculate the total unit charge for the condenser.

### Eq. 9:

System Cond. Chg. = toted unit charge x correction factor  
 System Cond. Chg. = 36.4 x 3.0 System Cond. Chg. = 109.2 lbs.

For multiple system condensers use the same procedure above, except in step 1 use the charge per circuit value from Table 9 instead of the total unit charge and multiply by the number of circuits for each system.

**For refrigerant line sizing see Pages 26-29 of Russell's refrigeration engineering manual.**

TABLE 9

### REFRIGERANT WEIGHTS, TOTAL AND PER CIRCUIT (LBS)

MODEL	MAX CIR QTY	R-22				MODEL	MAX CIR QTY	R-22			
		134a CHARGE PER CIRCUIT	134a TOTAL CHARGE UNIT	R-22 CHARGE PER CIRCUIT	R-22 TOTAL CHARGE UNIT			134a CHARGE PER CIRCUIT	134a TOTAL CHARGE UNIT	R-22 CHARGE PER CIRCUIT	R-22 TOTAL CHARGE UNIT
<b>"RAC" MODELS</b>						<b>"VAC" DOUBLE FAN WIDTH MODELS</b>					
RAC 3/4	12	0.06	0.7	0.06	0.7	VAC 59, VEQ 50	44	0.68	30.0	0.67	29.5
RAC 1	12	0.09	1.1	0.09	1.1	VAC 63, VEQ 56	60	0.67	39.9	0.66	39.3
RAC 1-1/2	12	0.09	1.1	0.09	1.1	VAC 68, VEQ 61	50	1.00	49.9	0.98	49.1
RAC 2	12	0.14	1.7	0.14	1.7	VAC 73, VEQ 65	50	1.00	49.9	0.98	49.1
RAC 3	12	0.18	2.2	0.18	2.2	VAC 83, VEQ 74	44	1.01	44.4	0.99	43.7
<b>"VAC" SINGLE FAN WIDTH MODELS</b>						VAC 95, VEQ 82	60	0.99	59.2	0.97	58.3
VAC 5	30	0.11	3.4	0.11	3.3	VAC 102, VEQ 91	50	1.48	74.0	1.46	72.8
VAC 6	30	0.11	3.4	0.11	3.3	VAC 116, VEQ 97	44	1.34	58.8	1.32	57.9
VAC 7	22	0.23	6.1	0.23	6.0	VAC 127, VEQ 107	60	1.31	78.4	1.29	77.2
VAC 8	30	0.22	6.7	0.22	6.6	VAC 134, VEQ 119	50	1.96	98.0	1.93	96.5
VAC 9	30	0.22	6.7	0.22	6.6	VAC 144, VEQ 126	50	1.96	98.0	1.93	96.5
VAC 11	30	0.21	6.3	0.21	6.2	VAC 158, VEQ 135	60	1.63	97.7	1.60	96.2
VAC 13	22	0.44	9.6	0.43	9.4	VAC 168, VEQ 149	50	2.44	122.0	2.40	120.2
VAC 15	22	0.44	9.6	0.43	9.4	VAC 180, VEQ 157	50	2.44	122.1	2.40	120.2
VAC 17	30	0.43	12.7	0.42	12.5	VAC 190, VEQ 161	60	1.96	117.3	1.93	115.4
VAC 19	25	0.64	16.0	0.63	15.7	VAC 202, VEQ 179	50	2.93	146.5	2.88	144.2
VAC 22, VEQ 21	22	0.68	14.9	0.67	14.7	VAC 216, VEQ 189	50	2.93	146.5	2.88	144.2
VAC 25, VEQ 23	22	0.68	14.9	0.67	14.7	For R-12 circuit or total charge multiply the R-22 values by 1.109 For R-502 circuit or total charge multiply the R-22 values by 1.013 For R-404A circuit or total charge multiply the R-22 values by 0.816 For R-507 circuit or total charge multiply the R-22 values by 0.863					
VAC 29, VEQ 24	22	0.68	14.9	0.67	14.7						
VAC 31, VEQ 27	30	0.67	20.0	0.66	19.7						
VAC 35, VEQ 32	25	1.00	25.0	0.98	24.6						
VAC 42, VEQ 36	22	1.01	22.3	0.99	21.9						
VAC 48, VEQ 40	30	0.99	29.6	0.97	29.1						
VAC 55, VEQ 45	25	1.48	37.0	1.46	36.4						
VAC 58, VEQ 49	22	1.34	29.5	1.32	29.0						
VAC 62, VEQ 54	30	1.31	39.2	1.29	38.6						
VAC 67, VEQ 60	25	1.96	49.1	1.93	48.3						
VAC 72, VEQ 64	25	1.96	49.1	1.93	48.3						
VAC 79, VEQ 69	30	1.63	48.9	1.60	48.1						
VAC 84, VEQ 75	25	2.44	61.1	2.40	60.1						
VAC 90, VEQ 80	25	2.44	61.1	2.40	60.1						
VAC 96, VEQ 81	30	1.96	58.6	1.93	57.7						
VAC 101, VEQ 89	25	2.93	73.3	2.88	72.1						
VAC 108, VEQ 94	25	2.93	73.3	2.88	72.1						

# Refrigerant Charge

TABLE 10 - REFRIGERANT CHARGE CORRECTION FACTOR WITH FLOODED-TYPE HEAD PRESSURE CONTROL

UNIT LENGTH*	DESIGN TD	MINIMUM DESIGN AMBIENT TEMPERATURE									
		60°	50°	40°	30°	20°	10°	0°	-10°	-20°	
WITHOUT FAN CYCLING											
ALL SIZES	30°	1.07	1.88	2.36	2.68	2.92	3.09	3.22	3.33	3.43	
	25°	1.61	2.28	2.68	2.95	3.15	3.29	3.40	3.49	3.56	
	20°	2.15	2.68	3.00	3.22	3.36	3.49	3.57	3.65	3.70	
	15°	2.68	3.09	3.33	3.49	3.59	3.70	3.75	3.81	3.85	
	10°	3.22	3.49	3.65	3.75	3.83	3.88	3.93	3.97	4.00	
WITH FAN CYCLING											
TWO FAN CELLS LONG	30°	1.03	1.05	1.07	1.60	1.99	2.28	2.50	2.68	2.83	
	25°	1.05	1.07	1.60	2.06	2.37	2.60	2.80	2.95	3.09	
	20°	1.05	1.60	2.15	2.50	2.76	2.95	3.11	3.22	3.32	
	15°	1.60	2.28	2.68	2.95	3.15	3.29	3.41	3.49	3.62	
	10°	2.50	2.95	3.22	3.41	3.53	3.60	6.69	3.75	3.81	
THREE FAN CELLS LONG	30°	1.01	1.01	1.03	1.05	1.07	1.37	1.77	2.03	2.24	
	25°	1.01	1.03	1.05	1.15	1.59	1.92	2.19	2.40	2.58	
	20°	1.04	1.06	1.27	1.77	2.04	2.40	2.62	2.78	2.92	
	15°	1.06	1.37	2.03	2.40	2.68	2.88	3.05	3.17	3.28	
	10°	1.78	2.40	2.78	3.05	3.22	2.34	3.46	3.53	3.61	
FOUR FAN CELLS LONG	30°	1.01	1.01	1.01	1.02	1.04	1.06	1.23	1.54	1.79	
	25°	1.01	1.01	1.03	1.05	1.07	1.43	1.74	2.01	2.21	
	20°	1.02	1.04	1.07	1.23	1.67	2.01	2.33	2.46	2.62	
	15°	1.05	1.07	1.54	2.01	2.33	2.58	2.75	2.92	3.05	
	10°	1.23	2.01	2.46	2.75	2.98	3.15	3.27	3.37	3.45	
FIVE FAN CELLS LONG	30°	1.00	1.00	1.00	1.00	1.00	1.01	1.01	1.06	1.36	
	25°	1.00	1.00	1.00	1.00	1.00	1.01	1.04	1.63	1.85	
	20°	1.00	1.00	1.00	1.01	1.20	1.63	2.07	2.19	2.36	
	15°	1.01	1.01	1.12	1.63	2.03	2.32	2.52	2.72	2.87	
	10°	1.01	1.65	2.13	2.46	2.72	2.92	3.10	3.23	3.33	
SIX FAN CELLS LONG	30°	1.00	1.00	1.00	1.00	1.00	1.00	1.00	1.00	1.09	
	25°	1.00	1.00	1.00	1.00	1.00	1.00	1.08	1.25	1.51	
	20°	1.00	1.00	1.00	1.00	1.08	1.21	1.79	1.94	2.10	
	15°	1.00	1.00	1.00	1.18	1.71	2.04	2.26	2.52	2.74	
	10°	1.00	1.35	1.83	2.19	2.37	2.69	2.94	3.11	3.23	

# Physical Data

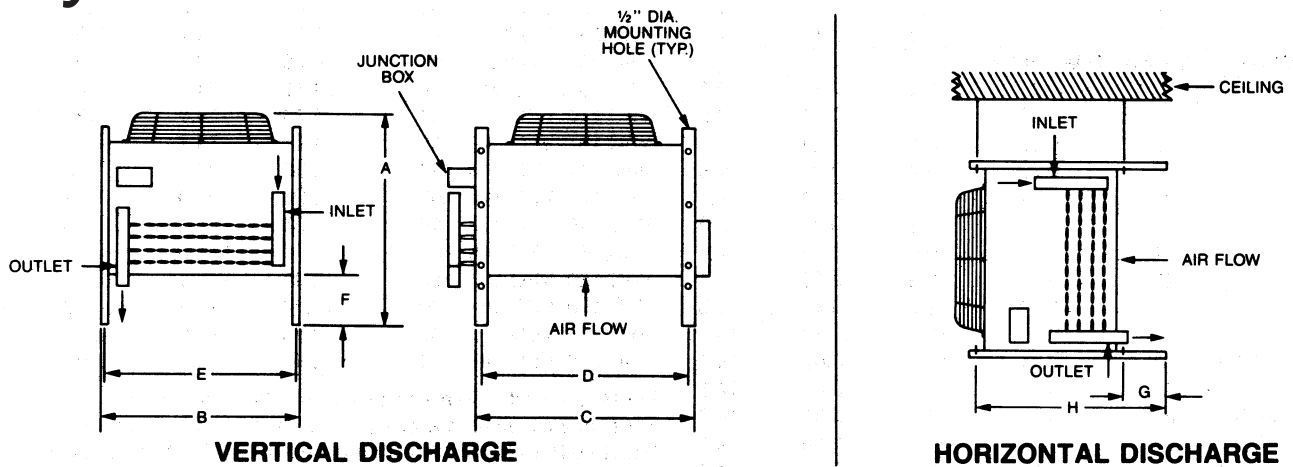

FIGURE 7: RAC models

TABLE 12

MODEL	DIMENSIONS (IN.)								CONNECTION SIZE O.D.						FAN DATA			APPROX NET WEIGHT	
	A	B	C	D	E	F	G	H	R-12		R-22		R-502		QTY	DIAM.	TOTAL CFM		
RAC-3/4	21	20-1/4	21	19-1/8	19-1/2	6	4-3/4	14-3/4	5/8	5/8	5/8	5/8	5/8	5/8	5/8	1	16	1440	60
RAC-1	21	20-1/4	21	19-1/8	19-1/2	6	4-3/4	14-3/4	5/8	5/8	5/8	5/8	5/8	5/8	5/8	1	16	2300	65
RAC-11/2	22	26-1/4	25	23-1/8	25-1/2	6	4-3/4	14-3/4	5/8	5/8	5/8	5/8	5/8	5/8	5/8	1	20	2600	90
RAC-2	22	26-1/4	25	23-1/8	25-1/2	6	4-3/4	14-3/4	5/8	5/8	5/8	5/8	5/8	5/8	5/8	1	20	2500	110
RAC-3	22	26-1/4	25	23-1/8	25-1/2	6	4-3/4	14-3/4	7/8	7/8	7/8	7/8	7/8	7/8	7/8	1	20	2400	145



# Physical Data

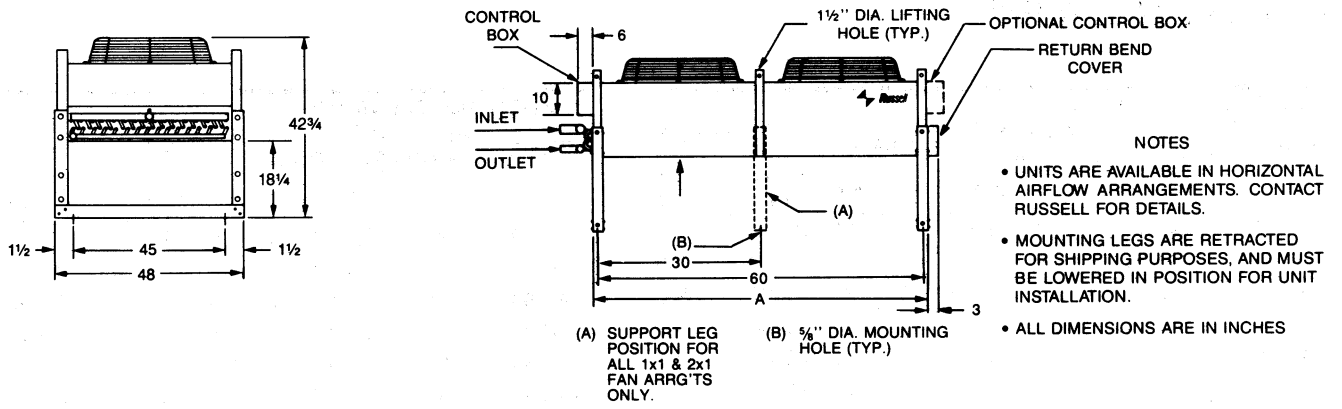

FIGURE 8: VAC 5 THRU 19, and CAC 5 THRU 19 models

TABLE 13 SINGLE WIDTH								TABLE 14 DOUBLE WIDTH							
MODEL VAC & CAC	DIMEN- SION (IN) A	(1) CONNECTION SIZE OD (IN)		QTY	DIAM.	TOTAL CFM	APPROX NET WEIGHT (LBS)	MODEL VAC & CAC	DIMEN- SION (IN) A	(1) CONNECTION SIZE OD (IN)		FAN DATA		TOTAL CFM	APPROX NET WEIGHT (LBS)
		IN	OUT							QTY	DIAM.				
5	32-1/4	1-1/8	1-1/8	1	24	5200	220	11	62-1/4	1-5/8	1-1/8	2	24	10400	340
6	32-1/4	1-3/8	1-3/8	1	24	5100	245	13	62-1/4	1-5/8	1-1/8	2	24	10200	355
7	32-1/4	1-3/8	1-3/8	1	24	5000	270	15	62-1/4	1-5/8	1-1/8	2	24	10000	370
8	32-1/4	1-3/8	1-3/8	1	24	4900	295	17	62-1/4	1-5/8	1-1/8	2	24	9800	400
9	32-1/4	1-5/8	1-1/8	1	24	4800	305	19	62-1/4	2-1/8	1-3/8	2	24	9600	420

NOTE: (1) Actual connection sizes may depend on refrigerant type and load. Contact factory for specifications.

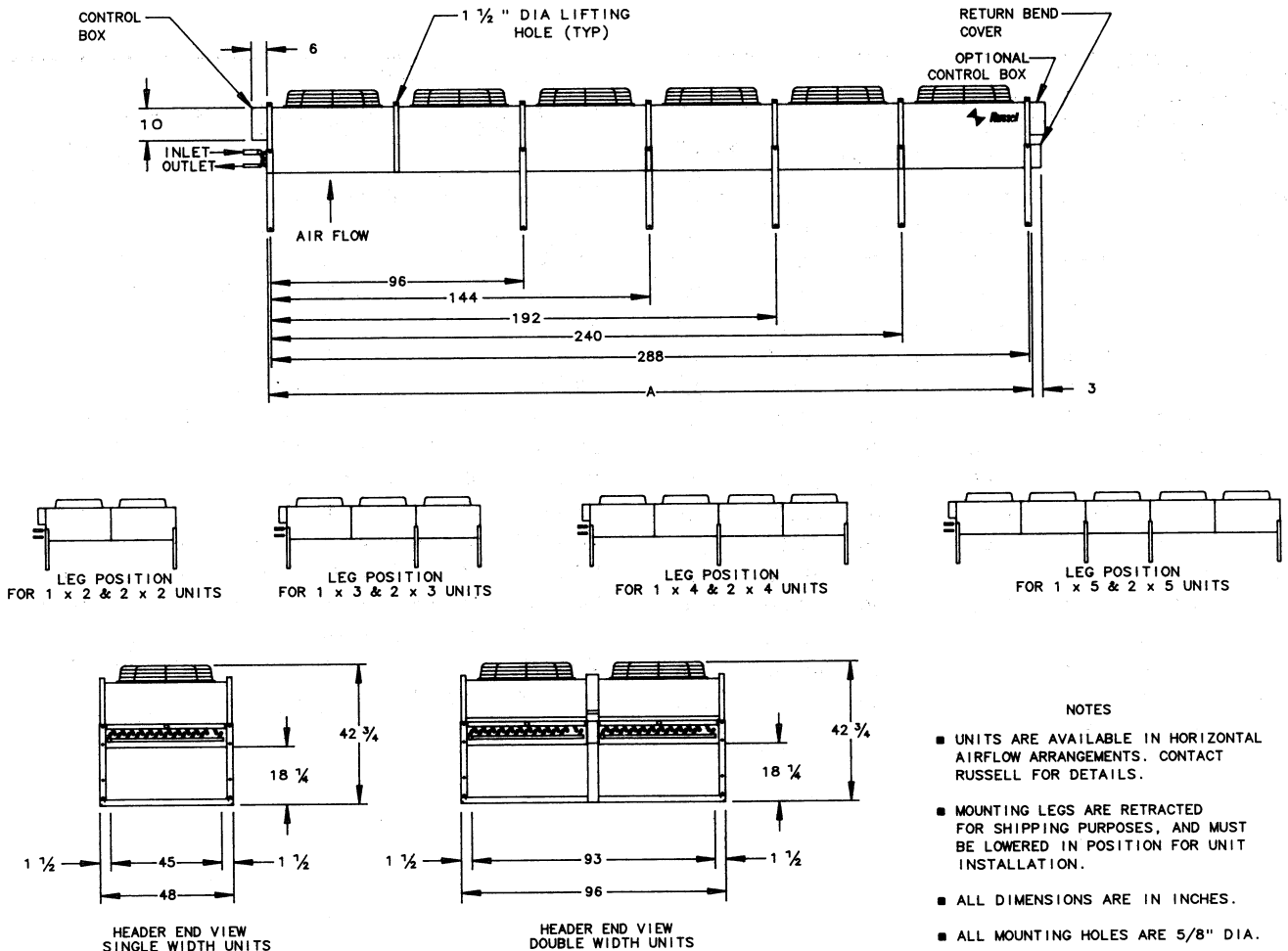

FIGURE 9: VAC 22 THRU 216 and VEQ 21 THRU 189 models

# Physical Data

**TABLE 15 SINGLE WIDTH**

MODEL	DIMEN- SION (IN)	(1) CONNECTION SIZE OD (IN)		FAN DATA			APPROX NET WEIGHT (LBS)
		A	IN	OUT	QTY	DIAM	
VAC 22	98-1/4	1-5/8	1-1/8	2	30	22000	465
VAC 25	98-1/4	1-5/8	1-1/8	2	30	21500	495
VAC 29	98-1/4	1-5/8	1-1/8	2	30	21000	520
VAC 31	98-1/4	1-5/8	1-1/8	2	30	20500	550
VAC 35	98-1/4	2-1/8	1-1/8	2	30	20000	600
VAC 42	146-1/4	2-1/8	1-1/8	3	30	32000	800
VAC 48	146-1/4	2-1/8	1-1/8	3	30	31500	900
VAC 55	146-1/4	2-1/8	1-3/8	3	30	31000	1000
VAC 58	194-1/4	2-1/8	1-3/8	4	30	42000	1050
VAC 62	194-1/4	2-1/8	1-3/8	4	30	41000	1100
VAC 67	194-1/4	2-5/8	1-3/8	4	30	40500	1150
VAC 72	194-1/4	2-5/8	1-3/8	4	30	40000	1200
VAC 79	242-1/4	2-5/8	1-3/8	5	30	51250	1370
VAC 84	242-1/4	2-5/8	1-3/8	5	30	50625	1430
VAC 90	242-1/4	2-5/8	1-3/8	5	30	50000	1490
VAC 96	290-1/4	2-5/8	1-3/8	6	30	61500	1690
VAC 101	290-1/4	2-5/8	1-3/8	6	30	60750	1750
VAC 108	290-1/4	2-5/8	1-3/8	6	30	60000	1830

**TABLE 16 DOUBLE WIDTH**

MODEL	DIMEN- SIONS (IN)	(1) CONNECTION SIZE OD (IN)		FAN DATA			APPROX NET WEIGHT (LBS)
		A	IN	OUT	QTY	DIAM	
VAC 59	98-1/4	(2)1-5/8	(2)1-1/8	4	30	42000	1080
VAC 63	98-1/4	(2)1-5/8	(2)1-1/8	4	30	41000	1140
VAC 68	98-1/4	(2)1-5/8	(2)1-1/8	4	30	40500	1190
VAC 73	98-1/4	(2)2-1/8	(2)1-1/8	4	30	40000	1240
VAC 83	146-1/4	(2)2-1/8	(2)1-1/8	6	30	64000	1640
VAC 95	146-1/4	(2)2-1/8	(2)1-1/8	6	30	63000	1840
VAC 102	146-1/4	(2)2-1/8	(2)1-3/8	6	30	62000	2050
VAC 116	194-1/4	(2)2-1/8	(2)1-3/8	8	30	84000	2150
VAC 127	194-1/4	(2)2-1/8	(2)1-3/8	8	30	82000	2250
VAC 134	194-1/4	(2)2-5/8	(2)1-3/8	8	30	81000	2350
VAC 144	194-1/4	(2)2-5/8	(2)1-3/8	8	30	80000	2460
VAC 158	242-1/4	(2)2-5/8	(2)1-3/8	10	30	102500	2800
VAC 168	242-1/4	(2)2-5/8	(2)1-3/8	10	30	101250	2950
VAC 180	242-1/4	(2)2-5/8	(2)1-3/8	10	30	100000	3075
VAC 190	290-1/4	(2)2-5/8	(2)1-3/8	12	30	123000	3400
VAC 202	290-1/4	(2)2-5/8	(2)1-3/8	12	30	121500	3620
VAC 216	290-1/4	(2)2-5/8	(2)1-3/8	12	30	120000	3750

**TABLE 17 SINGLE WIDTH**

MODEL	DIMEN- SIONS (IN)	(1) CONNECTION SIZE OD (IN)		FAN DATA			APPROX NET WEIGHT (LBS)
		A	IN	OUT	QTY	DIAM	
VEQ 21	98-1/4	1-5/8	1-1/8	2	30	16400	465
VEQ 23	98-1/4	1-5/8	1-1/8	2	30	16000	495
VEQ 24	98-1/4	1-5/8	1-1/8	2	30	15700	520
VEQ 27	98-1/4	1-5/8	1-1/8	2	30	15300	550
VEQ 32	98-1/4	2-1/8	1-1/8	2	30	14900	600
VEQ 36	146-1/4	2-1/8	1-1/8	3	30	23900	800
VEQ 40	146-1/4	2-1/8	1-1/8	3	30	23500	900
VEQ 45	146-1/4	2-1/8	1-3/8	3	30	23100	1000
VEQ 49	194-1/4	2-1/8	1-3/8	4	30	31300	1050
VEQ 54	194-1/4	2-1/8	1-3/8	4	30	30600	1100
VEQ 60	194-1/4	2-5/8	1-3/8	4	30	30200	1150
VEQ 64	194-1/4	2-5/8	1-3/8	4	30	29800	1200
VEQ 69	242-1/4	2-5/8	1-3/8	5	30	38200	1370
VEQ 75	242-1/4	2-5/8	1-3/8	5	30	37800	1430
VEQ 80	242-1/4	2-5/8	1-3/8	5	30	37300	1490
VEQ 81	290-1/4	2-5/8	1-3/8	6	30	45900	1690
VEQ 89	290-1/4	2-5/8	1-3/8	6	30	45300	1750
VEQ 94	290-1/4	2-5/8	1-3/8	6	30	44800	1830

**TABLE 18 DOUBLE WIDTH**

MODEL	DIMEN- SIONS (IN)	(1) CONNECTION SIZE OD (IN)		FAN DATA			APPROX NET WEIGHT (LBS)
		A	IN	OUT	QTY	DIAM	
VEQ 50	98-1/4	(2) 1-5/8	(2) 1-1/8	4	30	31300	1080
VEQ 56	98-1/4	(2)1-5/8	(2) 1-1/8	4	30	30600	1140
VEQ 61	98-1/4	(2) 1-5/8	(2) 1-1/8	4	30	30200	1190
VEQ 65	98-1/4	(2) 2-1/8	(2) 1-1/8	4	30	29800	1240
VEQ 74	146-1/4	(2) 2-1/8	(2) 1-1/8	6	30	47700	1640
VEQ 82	146-1/4	(2) 2-1/8	(2) 1-1/8	6	30	47000	1840
VEQ 91	146-1/4	(2) 2-1/8	(2) 1-3/8	6	30	46200	2050
VEQ 97	194-1/4	(2) 2-1/8	(2) 1-3/8	8	30	62600	2150
VEQ 107	194-1/4	(2) 2-1/8	(2) 1-3/8	8	30	61100	2250
VEQ 119	194-1/4	(2) 2-5/8	(2) 1-3/8	8	30	60400	2350
VEQ 126	194-1/4	(2) 2-5/8	(2) 1-1/8	8	30	59700	2460
VEQ 135	242-1/4	(2) 2-5/8	(2) 1-3/8	10	30	76400	2800
VEQ 149	242-1/4	(2) 2-5/8	(2) 1-3/8	10	30	75600	2950
VEQ 157	242-1/4	(2) 2-5/8	(2) 1-3/8	10	30	74600	3075
VEQ 161	290-1/4	(2) 2-5/8	(2) 1-3/8	12	30	91800	3400
VEQ 179	290-1/4	(2) 2-5/8	(2) 1-3/8	12	30	90600	3620
VEQ 189	290-1/4	(2) 2-5/8	(2) 1-3/8	12	30	89600	3750

# Electric Data

**TABLE 19**

MODEL	MOTOR QTY	MOTOR HP	MOTOR RPM	TOTAL MOTOR AMPS				
				SINGLE PHASE			THREE PHASE (1)	
				115V	208-230V	460V	208-230V	460V
RAC3/4TO3	1	1/6	1050	5.9	2.9			
VAC5TO9	1	3/4	1050		4.2	2.1	4.0	2.0
VAC11TO19	2	3/4	1050		8.4	4.2	8.0	4.0
CAC5TO9	1	3/4	1050		4.9	2.4		
CAC11TO19	2	3/4	1050		9.1	4.5		
CAC21TO28	3	3/4	1050		13.3	6.6		
CAC30TO40	4	3/4	1050		17.5	8.7		

All VAC 5 thru 19 models in this column have optional inherent 3 phase motors.

**TABLE 20**

MODEL	MOTOR QTY	MOTOR HP	MOTOR RPM	TOTAL MOTOR AMPS	
				THREE PHASE	
				208-230V	460V
VAC 22	2	1-1/2	1140	12.8	6.4
VAC 25	2	1-1/2	1140	12.8	6.4
VAC 29	2	1-1/2	1140	12.8	6.4
VAC 31	2	1-1/2	1140	12.8	6.4
VAC 35	2	1-1/2	1140	12.8	6.4
VAC 42	3	1-1/2	1140	19.2	9.6
VAC 48	3	1-1/2	1140	19.2	9.6
VAC 55	3	1-1/2	1140	19.2	9.6
VAC 58	4	1-1/2	1140	25.6	12.8
VAC 62	4	1-1/2	1140	25.6	12.8
VAC67	4	1-1/2	1140	25.6	12.8
VAC72	4	1-1/2	1140	25.6	12.8
VAC79	5	1-1/2	1140	32.0	16.0
VAC 84	5	1-1/2	1140	32.0	16.0
VAC 90	5	1-1/2	1140	32.0	16.0
VAC 96	6	1-1/2	1140	38.4	19.2
VAC 101	6	1-1/2	1140	38.4	19.2
VAC 108	6	1-1/2	1140	38.4	19.2
<b>DOUBLE FAN WIDTH UNITS</b>					
VAC 59	4	1-1/2	1140	25.6	12.8
VAC 63	4	1-1/2	1140	25.6	12.8
VAC 68	4	1-1/2	1140	25.6	12.8
VAC 73	4	1-1/2	1140	25.6	12.8
VAC 83	6	1-1/2	1140	38.4	19.2
VAC 95	6	1-1/2	1140	38.4	19.2
VAC 102	6	1-1/2	1140	38.4	19.2
VAC116	8	1-1/2	1140	51.2	25.6
VAC 127	8	1-1/2	1140	51.2	25.6
VAC 134	8	1-1/2	1140	51.2	25.6
VAC 144	8	1-1/2	1140	51.2	25.6
VAC 158	10	1-1/2	1140	64.0	32.0
VAC 168	10	1-1/2	1140	64.0	32.0
VAC 180	10	1-1/2	1140	64.0	32.0
VAC 190	12	1-1/2	1140	76.8	38.4
VAC202	12	1-1/2	1140	76.8	38.4
VAC216	12	1-1/2	1140	76.8	38.4

**TABLE 21**

MODEL	MOTOR QTY	MOTOR HP	MOTOR RPM	TOTAL MOTOR AMPS	
				THREE PHASE	
				208-230V	460V
VEQ-21	2	1	850	10.6	5.3
VEQ-23	2	1	850	10.6	5.3
VEQ-24	2	1	850	10.6	5.3
VEQ-27	2	1	850	10.6	5.3
VEQ-32	2	1	850	10.6	5.3
VEQ-36	3	1	850	15.9	8.0
VEQ-40	3	1	850	15.9	8.0
VECM5	3	1	850	15.9	8.0
VEQ-49	4	1	850	21.2	10.6
VEQ-54	4	1	850	21.2	10.6
VEQ-60	4	1	850	21.2	10.6
VEQ-64	4	1	850	21.2	10.6
VEQ-69	5	1	850	26.5	13.3
VEQ-75	5	1	850	26.5	13.3
VEQ-80	5	1	850	26.5	13.3
VEQ-81	6	1	850	31.8	15.9
VEQ-89	6	1	850	31.8	15.9
VEQ-94	6	1	850	31.8	15.9
<b>DOUBLE FAN WIDTH UNITS</b>					
VEQ-50	4	1	850	21.2	10.6
VEQ-56	4	1	850	21.2	10.6
VEQ-61	4	1	850	21.2	10.6
VEQ-65	4	1	850	21.2	10.6
VEQ-74	6	1	850	31.8	15.9
VEQ-82	6	1	850	31.8	15.9
VEQ-91	6	1	850	31.8	15.9
VEQ-97	8	1	850	42.4	21.2
VEQ-107	8	1	850	42.4	21.2
VEQ-119	8	1	850	42.4	21.2
VEQ-126	8	1	850	42.4	21.2
VEQ-135	10	1	850	53.0	26.5
VEQ-149	10	1	850	53.0	26.5
VEQ-157	10	1	850	53.0	26.5
VEQ-161	12	1	850	63.6	31.8
VEQ-179	12	1	850	63.6	31.8
VEQ-189	12	1	850	63.6	31.8

**REPLACEMENT PARTS - LISTING BY PRODUCT MODEL NUMBER  
MULTICON COMPUTER ROOM AIR COOLED CONDENSER - MODELS CAC**

MODEL NUMBER	DESCRIPTION	PART NUMBER
CAC 5 THRU CAC 72	CAPACITOR, 7.5 MFD, 208/1/60 MOTORS ONLY	202163-008
	CAPACITOR, 5 MFD, 230/460/1/60 MOTORS ONLY	202163-007
CAC 5 THRU CAC 60	FAN BLADES, 24" DIAM., 32 <sup>S</sup> PITCH, CW ROTATION, 1/2" BORE	213455-000
CAC 62, CAC 67, CAC 72	FAN BLADES, (HEADER END ONLY) 24" DIAM., 32 <sup>S</sup> PITCH, CW ROT., 1/2" BORE	213455-000
	FAN BLADES, (NON-HEADER END) 30" DIAM., 24 <sup>S</sup> PITCH, CW ROT. 5/8" BORE	210385-000
CAC 5 THRU CAC 60	FAN GUARD, WIRE, EPOXY COATED (BLUE), 24"	202136-001
CAC 62, CAC 67, CAC 72	FAN GUARD, WIRE, EPOXY COATED (BLUE), 24"	202136-001
	FAN GUARD, WIRE, EPOXY COATED (BLUE), 30"	202136-006
CAC 5 THRU CAC 60	MOTOR, (HEADER END VARI-SPEED), PSC, 3/4 HP, 1075RPM, 208-230/60/1	205051-015
	MOTOR, (NON-HEADER END), PSC, 3/4 HP, 1075 RPM, 208-230/60/1	205051-009
CAC 5 THRU CAC 60	MOTOR, (HEADER END VARI-SPEED), PSC, 3/4 HP, 1075 RPM, 460/60/1	205051-016
	MOTOR, (NON-HEADER END), PSC, 3/4 HP, 1075 RPM, 460/60/1	205051-002
CAC 62, CAC 67, CAC 72	MOTOR, (HEADER END VARI-SPEED), PSC, 3/4 HP, 1075 RPM, 208-230/60/1	205051-015
	MOTOR, (NON-HEADER END), 1 -1/2 HP, 1075 RPM, 208-230/460/60/3	110204-000
CAC 62, CAC 67, CAC 72	MOTOR, (HEADER END VARI-SPEED), PSC, 3/4 HP, 1075 RPM, 460/60/1	205051-016
CAC 5 THRU CAC 60	MOTOR MOUNT, 24"	205269000
CAC 62, CAC 67, CAC 72	MOTOR MOUNT, (HEADER END), 24"	205269000
	MOTOR MOUNT, (NON-HEADER END), 30"	210203-000
ALL CAC MODELS	MOTOR SPEED CONTROLLER, SINGLE INPUT, 208-230/460/1/60 (P66AAB-6)	204464044
ALL CAC MODELS	MOTOR SPEED CONTROLLER, DUAL INPUT, 208-230/460/1/60 (P66BAB-3)	204464-045

**MULTICON AIR COOLED CONDENSERS AND FLUID COOLERS - MODELS RAC, FRAC**

RAC 3/4 TO 1	FAN BLADES, 16" DIAM., 27" PITCH, CW ROTATION, 1/2" BORE	N/A
RAC 1-1/2 THRU 3	FAN BLADES, 20" DIAM., 30 <sup>S</sup> PITCH, CW ROTATION, 1/2" BORE	N/A
RAC 3/4, 1	FAN GUARD, WIRE, EPOXY COATED (BLUE), 16"	201006004
RAC 1-1/2 THRU 3	FAN GUARD, WIRE, EPOXY COATED (BLUE), 20"	201006-007
ALL MODELS	MOTOR, SHADED POLE, 1/6 HP, 1050 RPM, 115/208-230/1	102542-007

**MULTICON AIR COOLED CONDENSERS AND FLUID COOLERS - MODELS VAC, VEQ, FVAC**

VAC 5 THRU 19	CAPACITOR, 7.5 MFD, 208/1/60 MOTORS ONLY	202163-008
	CAPACITOR, 5 MFD, 230/460/1/60 MOTORS ONLY	202163007
VAC 5 THRU 19	FAN BLADES, 24" DIAM., 32" PITCH, CW ROTATION, 1/2" BORE	213455-000
VAC 22 THRU 216, & VEQ21 thru VEQ 189	FAN BLADES, 30" DIAM., 24 <sup>S</sup> PITCH, CW ROTATION, 5/8" BORE	210385-000
VAC 5 THRU 19	FAN GUARD, WIRE, EPOXY COATED (BLUE), 24"	202136-001
VAC 22 THRU 216, & VEQ 21 thru VEQ 189	FAN GUARD, WIRE, EPOXY COATED (BLUE), 30"	202136-006
VAC 5 THRU 19	MOTOR, PSC, 3/4 HP, 1075RPM, 208-230/60/1	205051-009
	MOTOR, PSC, 3/4 HP, 1075RPM, 460/1/60	205051-002
VEQ21 thru VEQ189	MOTOR, 1 HP, 850 RPM, 208-230/460/60/3	114105-000
VAC 22 THRU 216	MOTOR, 1-1/2HP,1140RPM,208-230/460/60/3	110204-000
VAC 5 THRU 19	MOTOR MOUNT, 24"	205269-000
VAC 22 THRU 216, & VEQ21 thru VEQ 189	MOTOR MOUNT, 30"	210203-000



**Russell**

221 S. Berry St., Brea, CA 92821 Tel (714) 529-1935 FAX (714) 529-7203