



R Series

Air Cooled Condensing Units

1/2 to 6 HP

Brochure 502.17

September 2011

1/2 to 3 HP



4 to 6 HP

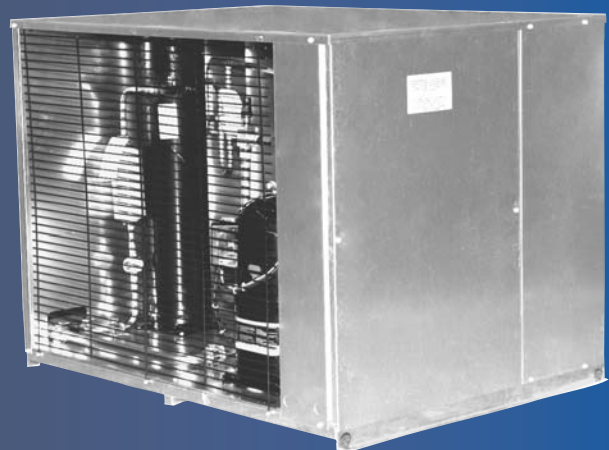

FEATURES AND OPTIONS

Description

Minicon R-series condensing units are ideally suited for use in a variety of commercial applications such as cafeterias, convenience stores, restaurants and fast food outlets. Minicon units offer a winning combination of quality, economy, and flexibility coupled with lower long term operating costs.

This low profile product line has been designed around environmentally safer refrigerants. Units are available with a choice of compressors: low cost hermetic, efficient and quiet scroll compressors or heavy duty semi-hermetic and discus compressors.

In addition to the basic Indoor and Outdoor models described in this bulletin, Russell can also provide pre-engineered system packages with matching evaporators and accessories.

The standard R-series condensing unit is designed for operation in ambient air temperatures up to 110°F. Oversized condensers are available for most models. Contact our Applications Engineering department for requirements exceeding 110°F ambient temperature.

Features

Indoor/Outdoor Models (REH/RES/RED/REO)

- Hermetic, Semi-hermetic or Scroll compressor.
- Generously sized condenser, Copper tubes/Aluminum fins
- Large electrical control panel for power and control circuits
- Compressor contactor or start kit
- Encapsulated high and low pressure controls (adjustable low pressure control on low temp models)
- Refrigerant receiver with shutoff valve and relief plug
- PSC motors are standard for all condenser fans
- All-weather housing
- UL and cUL listed for indoor or outdoor use

Optimized Packaged Units (RLH / RLS / RLD / RLO)

- Includes all Indoor model features - plus:
- Liquid line kit with filter/drier and sight glass with moisture indicator
- Suction line piping to exterior of cabinet
- Low Ambient - flooded head pressure control valve
- Crankcase heater
- Electric defrost timer with defrost contactor/relay on low temperature models (ED10-230/1)
- Air Defrost Timer (2-1/2 through 6 HP High and Medium temp models only, optional for other HP)

Options

- Factory installed air defrost timer
- Factory installed electric defrost timer with contactor
- Low ambient flooded control (STD on RL models)
- Mild ambient fan cycle control (for 2 fan units only)
- Suction line piping to exterior of cabinet (STD on RL models)
- Suction line kit with filter and piping
- Liquid line (piping only)
- Liquid line kit with piping, filter/ drier and sight glass (STD on RL models)
- Suction accumulator
- Oil separator (not available with mounted accumulator)
- Crankcase heater
- Copper fins, or coated condenser coil
- Tiered stacking
- Liquid line solenoid
- Fused disconnect
- High ambient oversized condenser coil - contact Applications
- Spring mounting for semi-hermetic compressors

FEATURES AND OPTIONS

	DESCRIPTION	STANDARD UNITS				PACKAGED UNITS			
		REH	RED	RES	REO	RLH	RLD	RLS	RLO
COMPRESSOR	Hermetic	STD	N/A	N/A	N/A	STD	N/A	N/A	N/A
	Discus	N/A	STD	N/A	N/A	N/A	STD	N/A	N/A
	Semi-Hermetic	N/A	N/A	STD	N/A	N/A	N/A	STD	N/A
	Scroll	N/A	N/A	N/A	STD	N/A	N/A	N/A	STD
ELECTRICAL CONTROLS	Oil failure control (as required)	N/R	STD	STD	N/R	N/R	STD	STD	N/R
	Encapsulated high and low pressure controls**	STANDARD				STANDARD			
	Compressor contactor (1Ø or 3Ø), start kit (1Ø)	STANDARD				STANDARD			
	Control transformer (460v to 230V) as required	STANDARD				STANDARD			
CONDENSER	Copper tubes, Aluminum fins	STANDARD				STANDARD			
	Fan motor(s) - overload protection	STANDARD				STANDARD			
	Fan blade(s) - individually balanced	STANDARD				STANDARD			
	Fan guard(s)	OPTIONAL				OPTIONAL			
PIPING COMPONENTS	Suction line (vibrasorber† and piping only)	OPTIONAL				STANDARD			
	Suction kit (vibrasorber†, piping and suction filter)	OPTIONAL				OPTIONAL			
	Suction line accumulator	OPTIONAL				OPTIONAL			
	*Liquid line kit	OPTIONAL				STANDARD			
	Discharge vibrasorber	N/R	STD††	STD††	N/R	N/R	STD††	STD††	N/R
RECEIVER	Shut-off valve(s)	STANDARD				STANDARD			
	Fusible plug	STANDARD				STANDARD			
HOUSING	Galvanized steel all weather housing	STANDARD				STANDARD			
	Control panel	STANDARD				STANDARD			
LOW AMBIENT CONTROLS	SIERRA	See publication No. 506				NOT AVAILABLE			
	HIGH SIERRA	See Publication No. 508				NOT AVAILABLE			
	Fan cycle control (2 Fan models only)	OPTIONAL				OPTIONAL			
	Flooded head pressure control	OPTIONAL				STANDARD			
DEFROST PROVISIONS	Air defrost time clock	OPTIONAL				STD on 3-6 HP			
	Electric defrost package	OPTIONAL				(1)	(1)	(1)	(1)
TESTING	UL and C-UL listed	STANDARD				STANDARD			
	Leak and dielectric tested before shipping	STANDARD				STANDARD			
	Dry Nitrogen shipping charge (25 to 35 PSI)	STANDARD				STANDARD			

STD = Standard Feature

N/R = Not Required

N/A = Not Available

OPT = Optional Feature

† Vibrasorber not required for Hermetic and Scroll compressors. Vibrasorber not included for 1/2 through 2HP models. Add kit SPR-VB if suction vibrasorber required.

†† Standard for 2-1/2 through 6HP Models. For 1/2 to 2HP models, add kit number SPR-VB to include vibrasorbers and compressor spring mounting.

*Liquid line kit includes: piping, filter drier, sight glass/moisture indicator.

** Adjustable low pressure control on low temp models in lieu of fixed control.

(1) Electric defrost kit is included on Low temperature models. ED-10-230/1 for 1/2 to 3 HP models, and ED11-230/3 for 4 to 6 HP models.

NOMENCLATURE

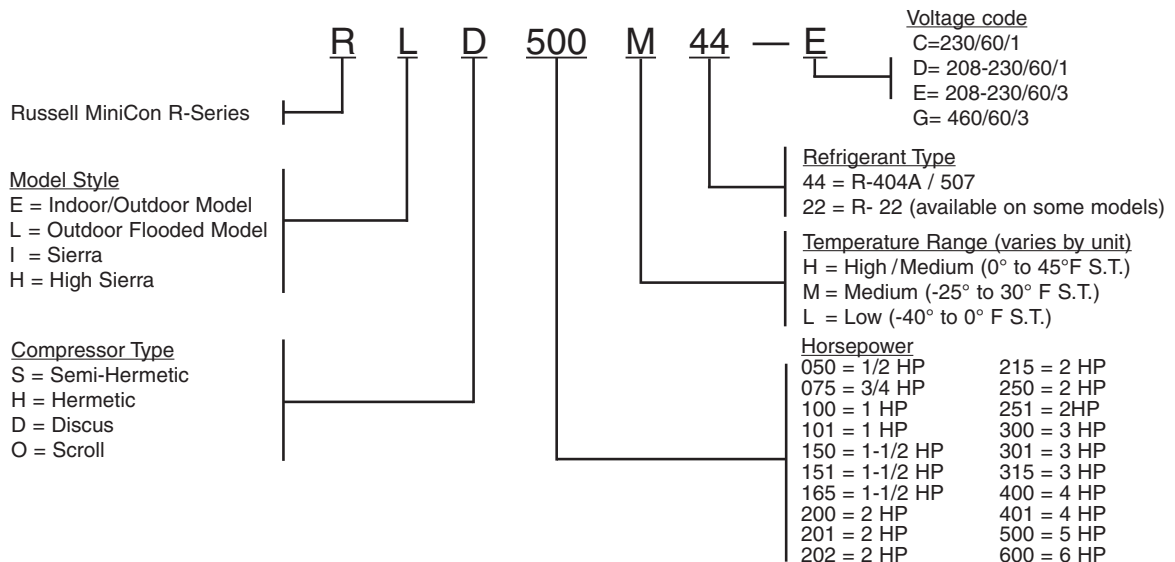

Performance Data - High / Medium Temp R-404A

HIGH TEMPERATURE - HERMETIC

MODEL	+40°F	+35°F
R*H055H44	9,250	8,340
R*H090H44	12,920	11,760
R*H100H44	14,140	12,760
R*H151H44	22,000	19,710
R*H251H44	27,160	24,500
R*H325H44	44,290	39,740
R*H400H44	54,970	49,440
R*H500H44	60,740	54,690

90°F
Ambient

EXTENDED MEDIUM TEMPERATURE - HERMETIC

MODEL	+30°F	+25°F	+20°F	+10°F	0°F	-10°F	-20°F	-25°F
R*H055M44	6,920	6,250	5,620	4,500	3,500	2,660	1,930	1,610
R*H080M44	8,280	7,490	6,760	5,440	4,310	3,370	2,600	2,270
R*H090M44	9,560	8,700	7,890	6,420	5,130	4,030	3,100	2,710
R*H100M44	10,340	9,240	8,230	6,440	4,950	3,700	2,610	2,100
R*H125M44	14,370	12,920	11,560	9,120	7,030	5,240	3,740	3,080
R*H151M44	17,920	15,900	14,000	10,630	7,820	5,510	3,620	2,820
R*H200M44	19,470	17,420	15,510	12,030	9,040	6,550	4,520	3,680
R*H251M44	21,560	19,290	17,190	13,420	10,220	7,550	5,380	4,450
R*H301M44	29,370	26,270	23,360	18,080	13,580	9,790	6,730	5,490
R*H325M44	32,160	28,800	25,620	19,910	15,090	11,060	7,710	6,260
R*H400M44	45,080	40,010	35,350	27,080	20,240	14,690	10,350	8,600
R*H500M44	51,320	45,680	40,490	31,380	23,840	17,680	12,700	10,600

MODEL	+40°F	+35°F
R*H055H44	8,790	7,930
R*H090H44	12,290	11,180
R*H100H44	13,370	12,040
R*H151H44	20,690	18,500
R*H251H44	25,640	23,110
R*H325H44	41,760	37,400
R*H400H44	51,980	46,670
R*H500H44	57,460	51,670

95°F
Ambient

MODEL	+30°F	+25°F	+20°F	+10°F	0°F	-10°F	-20°F	-25°F
R*H055M44	6,620	5,970	5,120	4,070	3,160	2,380	1,710	1,420
R*H080M44	7,840	7,080	6,090	4,890	3,870	3,010	2,320	2,030
R*H090M44	9,080	8,260	7,140	5,800	4,620	3,610	2,770	2,420
R*H100M44	9,730	8,690	7,380	5,760	4,410	3,260	2,240	1,750
R*H125M44	13,570	12,180	10,390	8,160	6,250	4,620	3,240	2,640
R*H151M44	16,830	14,860	13,050	9,840	7,170	4,980	3,180	2,420
R*H200M44	18,270	16,310	13,820	10,650	7,940	5,680	3,860	3,110
R*H251M44	20,290	18,130	15,390	11,960	9,060	6,640	4,670	3,840
R*H301M44	27,650	24,690	21,900	16,850	12,550	8,960	6,100	4,960
R*H325M44	30,190	26,960	23,920	18,520	13,940	10,110	6,910	5,500
R*H400M44	42,300	37,480	33,040	25,210	18,750	13,550	9,500	7,880
R*H500M44	48,440	43,050	36,380	28,110	21,270	15,700	11,190	9,270

MODEL	+40°F	+35°F
R*H055H44	8,330	7,510
R*H090H44	11,650	10,590
R*H100H44	12,590	11,330
R*H151H44	19,380	17,290
R*H251H44	24,130	21,720
R*H325H44	39,230	35,070
R*H400H44	48,960	43,880
R*H500H44	54,170	48,640

100°F
Ambient

MODEL	+30°F	+25°F	+20°F	+10°F	0°F	-10°F	-20°F	-25°F
R*H055M44	6,290	5,670	5,080	4,020	3,110	2,330	1,650	1,360
R*H080M44	7,390	6,670	6,010	4,810	3,790	2,940	2,260	1,980
R*H090M44	8,600	7,810	7,070	5,720	4,550	3,540	2,710	2,370
R*H100M44	9,120	8,140	7,240	5,640	4,290	3,130	2,080	1,550
R*H125M44	12,770	11,450	10,210	7,980	6,060	4,430	3,050	2,450
R*H151M44	15,710	13,840	12,120	9,070	6,540	4,460	2,750	2,030
R*H200M44	17,070	15,200	13,450	10,280	7,590	5,370	3,590	2,850
R*H251M44	19,030	16,970	15,060	11,650	8,770	6,380	4,430	3,600
R*H301M44	25,930	23,100	20,440	15,630	11,550	8,160	5,510	4,470
R*H325M44	28,200	25,120	22,260	17,130	12,800	9,160	6,110	4,740
R*H400M44	39,570	34,990	30,790	23,390	17,320	12,460	8,710	7,200
R*H500M44	45,580	40,460	35,760	27,540	20,760	15,240	10,750	8,840

MODEL	+40°F	+35°F
R*H055H44	7,410	6,660
R*H090H44	10,350	9,390
R*H100H44	11,050	9,920
R*H151H44	16,790	14,910
R*H251H44	21,130	18,930
R*H325H44	34,160	30,410
R*H400H44	42,860	38,280
R*H500H44	47,540	42,580

110°F
Ambient

MODEL	+30°F	+25°F	+20°F	+10°F	0°F	-10°F	-20°F	-25°F
R*H055M44	5,630	5,050	4,520	3,550	2,720	2,000	1,380	1,110
R*H080M44	6,490	5,850	5,250	4,170	3,260	2,520	1,930	1,700
R*H090M44	7,600	6,900	6,230	5,020	3,960	3,070	2,340	2,040
R*H100M44	7,930	7,060	6,270	4,850	3,630	2,540	1,490	950
R*H125M44	11,210	10,000	8,880	6,860	5,130	3,650	2,380	1,820
R*H151M44	13,510	11,830	10,290	7,560	5,310	3,450	1,940	1,270
R*H200M44	14,700	13,010	11,430	8,590	6,210	4,260	2,700	2,040
R*H251M44	16,510	14,680	12,970	9,930	7,360	5,240	3,520	2,790
R*H301M44	22,550	19,980	17,560	13,260	9,610	6,660	4,440	3,630
R*H325M44	24,350	21,560	19,010	14,440	10,570	7,310	4,490	3,210
R*H400M44	34,180	30,140	26,420	19,890	14,590	10,410	7,220	5,930
R*H500M44	39,960	35,370	31,180	23,840	17,820	12,900	8,860	7,110

Performance Data - High / Medium Temp R-404A

MEDIUM TEMPERATURE - SEMI HERMETIC - CAPACITY (BTUH)

	MODEL	+25°F	+20°F	+15°F	+10°F	+5°F	0°F	-5°F
90°F Ambient	R*S100M44	8,740	7,860	7,040	6,290	5,600	4,970	4,390
	R*S200M44	15,220	13,620	12,150	10,810	9,600	8,510	7,540
	R*S250M44	18,020	16,110	14,350	12,720	11,240	9,900	8,690
	R*S300M44	28,110	25,130	22,370	19,840	17,510	15,390	13,460
95°F Ambient	R*S100M44	8,260	7,420	6,640	5,920	5,260	4,660	4,120
	R*S200M44	14,400	12,870	11,470	10,210	9,060	8,030	7,120
	R*S250M44	16,980	15,160	13,480	11,940	10,530	9,260	8,120
	R*S300M44	26,700	23,820	21,170	18,740	16,510	14,470	12,630
100°F Ambient	R*S100M44	7,770	6,970	6,230	5,550	4,930	4,360	3,840
	R*S200M44	13,570	12,120	10,800	9,610	8,530	7,560	6,700
	R*S250M44	15,950	14,210	12,620	11,160	9,830	8,630	7,560
	R*S300M44	25,260	22,490	19,960	17,630	15,500	13,560	11,810
110°F Ambient	R*S100M44	6,800	6,080	5,420	4,810	4,250	3,750	3,290
	R*S200M44	11,940	10,650	9,480	8,420	7,470	6,630	5,870
	R*S250M44	13,880	12,330	10,910	9,620	8,450	7,400	6,470
	R*S300M44	22,330	19,810	17,510	15,400	13,480	11,740	10,170

HIGH TEMPERATURE - DISCUS - CAPACITY (BTUH)

	MODEL	+40°F	+30°F	+25°F	+20°F	+10°F	0°F	-10°F
90°F Ambient	R*D500M44	66,700	54,330	48,830	43,720	34,630	27,000	20,650
	R*D600M44	77,920	63,980	57,730	51,910	41,490	32,650	25,240
95°F Ambient	R*D500M44	63,420	51,560	46,300	41,430	32,750	25,480	19,430
	R*D600M44	74,080	60,760	54,790	49,220	39,280	30,860	23,820
100°F Ambient	R*D500M44	60,100	48,810	43,790	39,140	30,880	23,960	18,230
	R*D600M44	70,210	57,530	51,850	46,560	37,090	29,080	22,390
110°F Ambient	R*D500M44	53,450	43,300	38,780	34,610	27,180	20,980	15,870
	R*D600M44	----	51,030	45,950	41,210	32,720	25,560	19,580

MEDIUM TEMPERATURE - SCROLL CAPACITY (BTUH)

	MODEL	+35°	+30°	+25°	+20°	+15°	+10°	0°
90°F Ambient	R*O200M44	22,590	20,970	18,770	17,890	16,480	15,070	12,530
	R*O250M44	27,900	25,840	23,860	21,960	20,200	18,440	15,290
	R*O315M44	32,050	29,930	27,750	25,610	23,540	21,480	17,610
	R*O350M44	38,310	35,840	33,300	30,430	28,180	25,950	21,400
	R*O400M44	45,320	41,700	38,770	35,670	32,820	30,190	25,550
	R*O600M44	51,920	49,240	45,530	42,340	38,840	35,540	29,670
95°F Ambient	R*O650M44	63,020	59,090	55,220	51,210	47,120	43,820	36,250
	R*O200M44	21,930	20,350	18,820	17,360	16,000	14,630	12,160
	R*O250M44	27,080	25,050	23,160	21,320	19,610	17,900	14,840
	R*O315M44	31,110	29,050	26,940	24,860	22,860	20,850	17,090
	R*O350M44	37,190	34,790	32,330	29,540	27,370	25,190	20,770
	R*O400M44	44,000	40,480	37,640	34,630	31,970	29,310	24,800
100°F Ambient	R*O600M44	50,400	47,800	44,200	41,100	37,800	34,500	28,800
	R*O650M44	60,240	56,520	52,860	49,060	45,560	42,050	34,840
	R*O200M44	21,060	19,540	17,500	16,670	15,360	14,050	11,680
	R*O250M44	26,000	24,080	22,240	20,470	18,830	17,190	14,250
	R*O315M44	29,870	27,890	25,870	23,870	21,940	20,020	16,410
	R*O350M44	35,710	33,400	31,040	28,360	26,260	24,190	19,940
110°F Ambient	R*O400M44	42,240	38,870	36,140	33,250	30,590	28,140	23,810
	R*O600M44	48,390	45,890	42,440	39,460	36,200	33,120	27,650
	R*O650M44	57,410	53,900	50,450	46,860	43,190	40,230	33,390
	R*O200M44	20,040	18,320	16,950	16,150	14,880	13,030	11,310
	R*O250M44	24,750	22,580	21,540	19,830	18,240	15,940	13,810
	R*O315M44	28,450	26,150	25,060	23,120	21,260	18,560	15,900
110°F Ambient	R*O350M44	34,020	31,320	29,100	26,590	24,620	22,420	18,700
	R*O400M44	40,240	36,440	33,880	31,170	28,680	26,090	22,320
	R*O600M44	46,090	43,020	39,780	36,990	33,930	30,710	25,920
	R*O650M44	52,330	48,490	45,450	42,280	39,030	36,410	30,290

Performance Data - Low Temperature R-404A

LOW TEMPERATURE - HERMETIC - CAPACITY (BTUH)

	MODEL	0°F	-5°F	-10°F	-15°F	-20°F	-25°F	-30°F	-35°F	-40°F
90°F Ambient	R*H075L44	4,580	4,040	3,490	2,920	2,340	1,670	-----	-----	-----
	R*H100L44	5,930	5,200	4,480	3,780	3,070	2,340	-----	-----	-----
	R*H165L44	10,600	9,430	8,260	7,080	5,900	4,880	3,930	3,110	-----
	R*H215L44	17,080	15,270	13,450	11,340	9,230	7,660	-----	-----	-----
	R*H315L44	21,710	19,150	16,580	14,180	11,780	9,890	7,920	7,010	6,100
95°F Ambient	R*H075L44	4,400	3,880	3,350	2,800	2,250	1,600	-----	-----	-----
	R*H100L44	5,700	5,000	4,300	3,630	2,950	2,250	-----	-----	-----
	R*H165L44	10,190	9,070	7,940	6,810	5,670	4,690	3,770	2,840	-----
	R*H215L44	16,420	14,680	12,930	10,900	8,870	7,360	5,940	-----	-----
	R*H315L44	20,870	18,410	15,940	13,630	11,320	9,508	7,610	6,560	-----
100°F Ambient	R*H075L44	4,230	3,730	3,220	2,690	2,160	1,540	-----	-----	-----
	R*H100L44	5,480	4,800	4,130	3,490	2,840	2,160	-----	-----	-----
	R*H165L44	9,790	8,710	7,630	6,540	5,450	4,510	3,620	2,880	-----
	R*H215L44	15,770	14,090	12,420	10,470	8,520	7,070	-----	-----	-----
	R*H315L44	20,040	17,670	15,310	13,090	10,870	9,130	7,310	6,470	5,630
110°F Ambient	R*H075L44	3,950	3,490	3,010	2,520	2,020	1,440	-----	-----	-----
	R*H100L44	5,120	4,480	3,860	3,260	2,650	2,020	-----	-----	-----
	R*H165L44	9,200	8,190	7,170	6,150	5,130	4,240	3,410	2,710	-----
	R*H215L44	14,830	13,250	11,670	9,840	8,010	6,650	-----	-----	-----
	R*H315L44	18,830	16,610	14,390	12,300	10,220	8,590	6,870	6,090	5,290

LOW TEMPERATURE - SEMI HERMETIC - CAPACITY (BTUH)

	MODEL	0°F	-5°F	-10°F	-15°F	-20°F	-25°F	-30°F	-35°F	-40°F
90°F Ambient	R*S050L44	3,120	2,810	2,500	2,190	1,880	1,620	1,360	1,150	940
	R*S075L44	5,200	4,680	4,160	3,700	3,230	2,810	2,400	2,030	1,670
	R*S100L44	7,080	6,400	5,720	5,150	4,580	4,010	3,440	2,970	2,500
	R*S150L44	10,920	9,940	8,950	8,010	7,080	6,240	5,410	4,740	4,060
	R*S200L44	14,360	12,950	11,550	10,300	9,050	7,910	6,760	5,880	5,000
R*S300L44	21,740	19,560	17,370	15,340	13,320	11,500	9,680	8,120	6,560	
95°F Ambient	R*S050L44	3,000	2,700	2,400	2,100	1,800	1,550	1,300	1,060	900
	R*S075L44	5,000	4,500	4,000	3,550	3,100	2,700	2,300	1,880	1,600
	R*S100L44	6,800	6,150	5,500	4,950	4,400	3,850	3,300	2,760	2,400
	R*S150L44	10,500	9,550	8,600	7,700	6,800	6,000	5,200	4,420	3,900
	R*S200L44	13,800	12,450	11,100	9,900	8,700	7,600	6,500	5,480	4,300
R*S300L44	20,900	18,800	16,700	14,750	12,800	11,050	9,300	7,500	6,300	
100°F Ambient	R*S050L44	2,880	2,600	2,310	2,020	1,730	1,490	1,250	1,060	870
	R*S075L44	4,800	4,320	3,840	3,410	2,980	2,600	2,210	1,880	1,540
	R*S100L44	6,530	5,910	5,280	4,760	4,230	3,700	3,170	2,740	2,310
	R*S150L44	10,080	9,170	8,260	7,400	6,530	5,760	5,000	4,370	3,750
	R*S200L44	13,250	11,960	10,660	9,510	8,360	7,300	6,240	5,430	4,610
R*S300L44	20,070	18,050	16,040	14,160	12,290	10,610	9,330	7,490	6,050	
110°F Ambient	R*S050L44	2,690	2,430	2,160	1,890	1,620	1,400	1,170	990	820
	R*S075L44	4,480	4,030	3,580	3,190	2,790	2,430	2,070	1,760	1,440
	R*S100L44	6,090	5,510	4,920	4,440	3,950	3,460	2,960	2,570	2,160
	R*S150L44	9,390	8,550	7,700	6,900	6,090	5,370	4,660	4,080	3,500
	R*S200L44	12,340	11,150	9,940	8,860	7,790	6,800	5,820	5,070	4,300
R*S300L44	18,700	16,820	14,940	13,200	11,450	9,890	8,330	6,990	5,640	

Physical Dimensions - All Models. See specifications on page 15 for details.

Performance Data - Low Temperature R-404A

LOW TEMPERATURE - SCROLL - CAPACITY (BTUH)

	MODEL	0°F	-5°F	-10°F	-15°F	-20°F	-25°F	-30°F	-35°F	-40°F
90°F Ambient	R*O200L44	10,900	9,990	9,050	8,220	7,390	6,620	5,890	5,060	4,230
	R*O250L44	14,210	13,340	12,470	11,420	10,370	9,250	7,960	6,970	5,980
	R*O300L44	16,440	15,120	13,790	12,790	11,710	9,970	8,930	7,830	6,720
	R*O301L44	19,330	17,670	16,000	14,550	12,960	11,590	10,470	9,420	8,360
	R*O400L44	24,820	22,610	20,400	18,360	16,320	14,510	12,810	10,840	8,860
	R*O500L44	29,350	26,860	24,360	21,980	19,830	17,790	15,660	14,010	12,350
	R*O600L44	34,410	31,320	28,230	25,550	22,770	20,400	17,930	15,970	14,010
95°F Ambient	R*O200L44	11,330	10,370	9,400	8,540	7,670	6,870	6,110	4,700	4,390
	R*O250L44	13,800	12,950	12,100	11,080	10,060	8,980	7,720	6,760	5,800
	R*O300L44	15,960	14,670	13,380	12,410	11,360	9,680	8,670	7,600	6,520
	R*O301L44	18,760	17,150	15,530	14,120	12,580	11,250	10,160	9,140	8,110
	R*O400L44	24,090	21,950	19,800	17,820	15,940	14,080	12,430	10,520	8,600
	R*O500L44	28,490	26,070	23,650	21,340	19,250	17,270	13,200	13,600	11,990
	R*O600L44	33,400	30,400	27,400	24,800	22,100	19,800	17,600	15,500	13,600
100°F Ambient	R*O200L44	10,160	9,310	8,430	7,660	6,880	6,170	5,490	4,720	3,940
	R*O250L44	13,250	12,440	11,620	10,640	9,660	8,630	7,420	6,490	5,570
	R*O300L44	15,330	14,090	12,850	11,920	10,910	9,300	8,330	7,300	6,260
	R*O301L44	18,010	16,470	14,910	13,560	12,080	10,800	9,760	8,780	7,790
	R*O400L44	23,130	21,080	19,010	17,110	15,210	13,520	11,940	10,100	8,260
	R*O500L44	27,350	25,030	22,710	20,490	18,480	16,580	14,590	13,060	11,510
	R*O600L44	32,070	29,190	26,310	23,810	21,220	19,010	16,710	14,880	13,060
110°F Ambient	R*O200L44	9,530	8,730	7,910	7,180	6,450	5,780	5,140	4,420	3,690
	R*O250L44	12,420	11,660	10,890	9,980	9,060	8,090	6,950	6,090	5,220
	R*O300L44	14,370	13,210	12,050	11,170	10,230	8,720	7,810	6,840	5,870
	R*O301L44	16,890	15,440	13,980	12,710	11,330	10,130	9,150	8,230	7,300
	R*O400L44	21,690	19,760	17,820	16,040	14,260	12,680	11,190	9,470	7,740
	R*O500L44	25,650	23,470	21,290	19,210	17,330	15,550	13,680	12,240	10,800
	R*O600L44	30,060	27,360	24,660	22,320	19,890	17,820	15,660	13,950	12,240

LOW TEMPERATURE - DISCUS - CAPACITY (BTUH)

	MODEL	0°F	-5°F	-10°F	-15°F	-20°F	-25°F	-30°F	-35°F	-40°F
90°F Ambient	R*D300L44	30,890	27,820	24,760	21,900	19,040	16,640	14,250	12,120	9,990
	R*D400L44	35,470	31,670	27,880	25,280	22,680	20,130	17,580	15,550	13,520
	R*D500L44	41,080	37,240	33,390	29,850	26,320	23,350	20,390	18,000	15,600
95°F Ambient	R*D300L44	29,700	26,750	23,800	21,050	18,300	16,000	13,700	11,240	9,600
	R*D400L44	34,100	30,450	26,800	24,300	21,800	19,350	16,900	14,560	13,000
	R*D500L44	39,500	35,800	32,100	28,700	25,300	22,450	19,600	16,840	15,000
100°F Ambient	R*D300L44	28,520	25,680	22,850	20,210	17,570	15,360	13,160	11,190	9,220
	R*D400L44	32,740	29,240	25,730	23,330	20,930	18,580	16,230	14,360	12,480
	R*D500L44	37,920	34,370	30,820	27,560	24,290	21,560	18,820	16,610	14,400
110°F Ambient	R*D300L44	26,560	23,930	21,290	18,830	16,370	14,310	12,270	10,430	8,600
	R*D400L44	30,500	27,240	23,970	21,730	19,500	17,310	15,130	13,380	11,640
	R*D500L44	35,320	32,010	28,710	25,670	22,630	20,080	17,530	15,480	13,420

Physical Dimensions - All Models

See specifications on page 15 for details

Performance Data - High / Medium Temp R-22

EXTENDED MEDIUM TEMPERATURE - HERMETIC

	MODEL	+40°F	+35°F	+30°F	+25°F	+20°F	+15°F	+10°F	0°F
90°F AMBIENT	R*H051H22	7,780	7,130	6,470	5,990	5,280	4,700	4,110	3,020
	R*H075H22	9,310	8,460	7,600	6,820	6,040	5,340	4,630	3,330
	R*H100H22	13,520	12,280	11,030	9,940	8,840	7,840	6,820	4,940
	R*H151H22	16,790	15,940	15,080	13,340	11,910	10,550	9,190	5,850
	R*H201H22	23,540	21,960	20,380	16,890	14,960	13,200	11,440	8,230
	R*H251H22	30,740	28,010	25,270	22,970	20,860	18,140	15,410	11,000
	R*H301H22	38,190	34,960	31,730	28,670	25,300	22,220	19,140	13,600
R*H401H22	54,280	49,290	44,310	39,890	35,690	30,520	25,350	18,650	
R*H500H22	59,180	54,080	48,990	44,260	39,730	35,470	31,200	23,200	

	MODEL	+40°F	+35°F	+30°F	+25°F	+20°F	+15°F	+10°F	0°F
95°F AMBIENT	R*H051H22	7,550	6,920	6,280	5,810	5,120	4,560	3,990	2,930
	R*H075H22	8,950	8,130	7,300	6,550	5,800	5,130	4,450	3,200
	R*H100H22	13,000	11,800	10,600	9,550	8,500	7,530	6,550	4,750
	R*H151H22	16,300	15,470	14,640	12,950	11,560	10,240	8,920	5,675
	R*H201H22	22,850	21,320	19,780	16,390	14,520	12,810	11,100	7,990
	R*H251H22	29,840	27,190	24,530	22,300	20,250	17,610	14,960	10,670
	R*H301H22	37,070	33,940	30,800	27,830	24,560	21,570	18,580	13,200
R*H401H22	52,690	47,850	43,010	38,720	34,650	29,630	24,610	18,100	
R*H500H22	56,900	52,000	47,100	42,550	38,200	34,100	30,000	22,300	

	MODEL	+40°F	+35°F	+30°F	+25°F	+20°F	+15°F	+10°F	0°F
100°F AMBIENT	R*H051H22	7,330	6,720	6,100	5,640	4,970	4,430	3,880	2,850
	R*H075H22	8,600	7,810	7,010	6,290	5,570	4,930	4,280	3,080
	R*H100H22	12,480	11,330	10,180	9,170	8,160	7,230	6,290	4,560
	R*H151H22	15,820	15,010	14,210	12,570	11,220	9,940	8,660	5,510
	R*H201H22	22,170	20,690	19,190	15,900	14,090	12,430	10,770	7,760
	R*H251H22	28,950	26,380	23,800	21,640	19,650	17,090	14,520	10,350
	R*H301H22	35,960	32,930	29,880	27,000	23,830	20,930	18,030	12,810
R*H401H22	51,110	46,420	41,720	37,560	33,620	28,750	23,880	17,560	
R*H500H22	54,630	49,920	45,220	40,850	36,680	32,740	28,800	21,410	

	MODEL	+40°F	+35°F	+30°F	+25°F	+20°F	+15°F	+10°F	0°F
110°F AMBIENT	R*H051H22	6,890	6,320	5,740	5,310	4,680	4,170	3,650	2,680
	R*H075H22	8,020	7,270	6,530	5,860	5,190	4,590	3,990	2,880
	R*H100H22	11,640	10,560	9,490	8,550	7,610	6,750	5,860	4,250
	R*H151H22	14,890	14,130	13,380	11,840	10,570	9,370	8,160	5,190
	R*H201H22	20,870	19,470	18,070	14,970	13,260	11,700	10,140	7,310
	R*H251H22	27,250	24,830	22,400	20,370	18,500	16,090	13,670	9,740
	R*H301H22	33,850	31,000	28,130	25,410	22,430	19,710	16,970	12,060
R*H401H22	48,100	43,680	39,260	35,350	31,650	27,060	22,480	16,530	
R*H500H22	50,880	46,500	42,120	38,050	34,170	30,500	26,830	19,950	

HIGH TEMPERATURE - DISCUS - CAPACITY (BTUH)

Ambient	MODEL	+40°F	+35°F	+30°F	+25°F	+20°F	+15°F	+10°F	0°F
90°F	R*D500H22	66,700	61,050	55,400	50,200	45,350	40,770	36,200	----
95°F	R*D500H22	64,100	58,700	53,300	48,300	43,600	39,200	34,800	----
100°F	R*D500H22	61,500	49,920	51,200	46,400	41,900	37,640	33,400	----
110°F	R*D500H22	57,300	52,490	47,700	43,200	39,000	35,060	31,100	----

Performance Data - High / Medium Temp R-22

High Temperature - SEMI HERMETIC - (BTUH)

	MODEL	+40°F	+35°F	+30°F	+25°F	+20°F	+15°F	+10°F
90°F Ambient	R*S075H22	9390	8480	7580	6740	5960	5260	4550
	R*S100H22	12550	11460	10350	9340	8410	7570	6710
	R*S150H22	17270	15710	14150	12690	11240	10040	8840
	R*S200H22	23400	21270	19140	17270	15400	13680	11960
	R*S300H22	35880	32610	29330	26320	23510	21010	18520
95°F Ambient	R*S075H22	9020	8150	7280	6480	5730	5050	4370
	R*S100H22	12060	11010	9950	8980	8080	7270	6450
	R*S150H22	16600	15100	13600	12200	10800	9650	8500
	R*S200H22	22500	20450	18400	16600	14800	13150	11500
	R*S300H22	34500	31350	28200	25300	22600	20200	17800
100°F Ambient	R*S075H22	8660	7830	6990	6230	5510	4850	4200
	R*S100H22	11580	10570	9560	8630	7760	6980	6200
	R*S150H22	15940	14500	13060	11720	10370	9270	8160
	R*S200H22	21600	19640	17670	15940	14210	12630	11040
	R*S300H22	33120	30100	27080	24290	21700	19400	17090
110°F Ambient	R*S075H22	8080	7300	6520	5820	5140	4530	3920
	R*S100H22	10790	9850	8910	8050	7230	6510	5790
	R*S150H22	14860	13510	12170	10930	9670	8640	7610
	R*S200H22	20120	18300	16470	14860	13250	11770	10290
	R*S300H22	30850	28040	25220	22630	20220	18080	15920

MEDIUM TEMPERATURE - SCROLL - CAPACITY (BTUH)

	MODEL	+35°F	+30°F	+25°F	+20°F	+15°F	+10°F	0°F
90°F Ambient	R*O200M22	21,660	20,490	18,820	17,410	15,900	14,380	11,940
	R*O250M22	26,110	24,110	21,950	20,540	18,700	16,870	14,000
	R*O300M22	31,360	29,020	26,620	24,180	22,050	19,910	16,540
	R*O301M22	29,030	35,770	32,850	29,160	26,810	24,450	20,300
	R*O400M22	44,620	41,110	38,590	34,700	31,640	28,590	23,740
	R*O600M22	53,970	49,830	45,250	42,250	38,640	35,040	29,080
	R*O650M22	59,570	56,490	53,410	49,730	46,050	42,370	35,830
95°F Ambient	R*O200M22	21,020	19,890	18,270	16,900	15,430	13,960	11,590
	R*O250M22	25,340	23,400	21,310	19,940	18,155	16,370	13,590
	R*O300M22	30,440	28,170	25,840	23,470	21,400	19,330	16,050
	R*O301M22	28,180	34,720	31,890	28,310	26,020	23,730	19,700
	R*O400M22	43,320	39,910	37,460	33,680	30,715	27,750	23,040
	R*O600M22	52,390	48,370	43,930	41,010	37,510	34,010	28,230
	R*O650M22	57,830	54,840	51,850	48,280	44,705	41,130	34,780
100°F Ambient	R*O200M22	20,390	19,300	17,730	16,400	14,970	13,550	10,300
	R*O250M22	24,580	22,700	20,680	19,350	17,620	15,880	12,070
	R*O300M22	29,530	27,330	25,070	22,770	20,760	18,760	14,250
	R*O301M22	27,340	33,680	30,940	27,470	25,240	23,020	17,490
	R*O400M22	42,030	38,720	36,340	32,670	29,800	26,920	20,460
	R*O600M22	50,820	46,920	42,620	39,780	36,390	32,990	25,060
	R*O650M22	56,100	53,200	50,300	46,840	43,370	39,900	30,870
110°F Ambient	R*O200M22	19,190	18,170	16,690	15,440	14,100	12,760	10,600
	R*O250M22	23,140	21,360	19,460	18,210	16,590	14,950	12,420
	R*O300M22	27,800	25,730	23,600	21,430	19,540	17,660	14,660
	R*O301M22	25,730	31,690	29,120	25,860	23,760	21,670	17,990
	R*O400M22	39,550	36,440	34,200	30,740	28,050	25,340	21,030
	R*O600M22	47,830	44,160	40,110	37,440	34,250	31,050	25,780
	R*O650M22	50,900	48,260	45,630	42,490	39,350	36,200	31,270

Performance Data - Low Temperature - R-22

LOW TEMPERATURE R-22 - SEMI HERMETIC - CAPACITY (BTUH)

	MODEL	0°F	-5°F	-10°F	-15°F	-20°F	-25°F	-30°F	-35°F	-40°F
90°F Ambient	R*S050L22	3,440	3,020	2,600	2,220	1,820	1,510	1,200	970	730
	R*S075L22	5,670	5,030	4,370	3,830	3,280	2,810	2,340	1,960	1,560
	R*S100L22	7,490	6,660	5,830	5,100	4,370	3,780	3,180	2,710	2,240
	R*S200L22	8,840	7,780	6,710	5,880	5,050	4,370	3,700	3,120	2,550
	R*S201L22	11,810	10,490	9,160	7,990	6,820	5,830	4,840	3,990	3,120
	R*S300L22	14,360	12,740	11,130	9,680	8,220	7,020	5,830	5,050	4,270
	R*S300L22	21,430	19,090	16,750	14,560	12,380	10,460	8,530	7,210	5,880

95°F Ambient	R*S050L22	3,300	2,900	2,500	2,130	1,750	1,450	1,150	930	700
	R*S075L22	5,450	4,830	4,200	3,680	3,150	2,700	2,250	1,880	1,500
	R*S100L22	7,200	6,400	5,600	4,900	4,200	3,630	3,050	2,600	2,150
	R*S200L22	8,500	7,480	6,450	5,650	4,850	4,200	3,550	3,000	2,450
	R*S201L22	11,350	10,080	8,800	7,680	6,550	5,600	4,650	3,830	3,000
	R*S300L22	13,800	12,250	10,700	9,300	7,900	6,750	5,600	4,850	4,100
	R*S300L22	20,600	18,350	16,100	14,000	11,900	10,050	8,200	6,930	5,650

100°F Ambient	R*S050L22	3,170	2,790	2,400	2,050	1,680	1,400	1,110	900	680
	R*S075L22	5,240	4,640	4,040	3,540	3,030	2,600	2,160	1,810	1,440
	R*S100L22	6,920	6,150	5,380	4,710	4,040	3,490	2,930	2,500	2,070
	R*S200L22	8,160	7,190	6,200	5,430	4,660	4,040	3,410	2,880	2,360
	R*S201L22	10,900	9,680	8,450	7,380	6,290	5,380	4,470	3,680	2,880
	R*S300L22	13,250	11,760	10,280	8,930	7,590	6,480	5,380	4,660	3,940
	R*S300L22	19,780	17,620	15,460	13,440	11,430	9,650	7,880	6,660	5,430

110°F Ambient	R*S050L22	2,970	2,610	2,250	1,917	1,575	1,305	1,035	837	630
	R*S075L22	4,905	4,347	3,780	3,312	2,835	2,430	2,025	1,692	1,350
	R*S100L22	6,480	5,760	5,040	4,410	3,780	3,267	2,745	2,340	1,935
	R*S200L22	7,650	6,732	5,805	5,085	4,365	3,780	3,195	2,700	2,205
	R*S201L22	10,215	9,072	7,920	6,912	5,895	5,040	4,185	3,447	2,700
	R*S300L22	12,420	11,025	9,630	8,370	7,110	6,075	5,040	4,365	3,690
	R*S300L22	18,540	16,515	14,490	12,600	10,710	9,045	7,380	6,237	5,085

LOW TEMPERATURE R-22 - DISCUS - CAPACITY (BTUH)

	MODEL	0°F	-5°F	-10°F	-15°F	-20°F	-25°F	-30°F	-35°F	-40°F
90°F Ambient	R*D300L22	27,770	24,600	21,430	18,830	16,230	14,100	11,960	10,090	8,220
	R*D400L22	32,040	28,550	25,070	21,950	18,830	16,180	13,520	11,340	9,160
	R*D500L22	38,800	34,580	30,370	26,680	22,990	19,820	16,640	14,040	11,440

95°F Ambient	R*D300L22	26,700	23,650	20,600	18,100	15,600	13,550	11,500	9,700	7,900
	R*D400L22	30,800	27,450	24,100	21,100	18,100	15,550	13,000	10,900	8,800
	R*D500L22	37,300	33,250	29,200	25,650	22,100	19,050	16,000	13,500	11,000

100°F Ambient	R*D300L22	25,640	22,710	19,780	17,380	14,980	13,010	11,040	9,320	7,590
	R*D400L22	29,570	26,360	23,140	20,260	17,380	14,930	12,480	10,470	8,450
	R*D500L22	35,810	31,920	28,040	24,630	21,220	18,290	15,360	12,960	10,560

110°F Ambient	R*D300L22	24,000	21,300	18,500	16,300	14,000	12,200	10,400	8,730	7,110
	R*D400L22	27,720	24,705	21,690	18,990	16,290	13,995	11,700	9,810	7,920
	R*D500L22	33,570	29,925	26,280	23,085	19,890	17,145	14,400	12,150	9,900

Electrical Data / R-22

MODEL NUMBER	COMP. MODEL NUMBER	AMPS @ 208/230/1/60					AMPS @ 208/230/3/60					AMPS @ 460/3/60				
		COMPRESSOR		COND	TOTAL	MCA	COMPRESSOR		COND	TOTAL	MCA	COMPRESSOR		COND	TOTAL	MCA
		RLA	LRA	FLA	UNIT†	‡	RLA	LRA	FLA	UNIT†	‡	RLA	LRA	FLA	UNIT†	‡
HERMETIC																
R*H051H22	ART82C1	5.9	30.0	0.5	7.4	15.0	-----	-----	-----	-----	-----	-----	-----	-----	-----	-----
R*H075H22	RSE-0075	7.1	35.5	0.5	8.6	15.0	-----	-----	-----	-----	-----	-----	-----	-----	-----	-----
R*H100H22	RS70C1	7.0	34.2	0.5	8.5	15.0	4.7	31.0	0.5	6.2	15.0	-----	-----	-----	-----	-----
R*H151H22	CR18KQ	9.0	41.0	1.0	11.0	15.0	6.0	44.2	1.0	8.0	15.0	-----	-----	-----	-----	-----
R*H201H22	CR24KQ	13.5	70.5	1.0	15.5	20.0	7.5	40.0	1.0	9.5	15.0	-----	-----	-----	-----	-----
R*H251H22	CR33KQ	16.0	75.0	1.0	18.0	23.0	10.6	69.0	1.0	12.6	17.0	4.7	31.6	0.4	5.6	15.0
R*H301H22	CR41KQ	19.4	110.0	1.0	21.4	28.0	13.1	80.0	1.0	15.1	20.0	5.9	42.0	0.4	6.8	15.0
R*H401H22	CR53KQ	29.0	140.0	3.2	33.2	41.0	18.0	107.0	3.2	22.2	27.0	9.1	55.0	2.1	11.7	15.0
R*H500H22	CRN-0500	34.3	142.0	3.2	38.5	48.0	21.4	130.0	3.2	25.6	31.0	9.6	65.0	2.1	12.2	15.0

SCROLL

R*O200M22	ZS15K4E	13.6	55.0	1.0	15.6	20.0	9.3	55.0	1.0	11.3	15.0	4.3	27.0	0.4	5.2	15.0
R*O250M22	ZS19K4E	16.4	73.0	1.0	18.4	25.0	9.7	63.0	1.0	11.7	15.0	5.0	31.0	0.4	5.9	15.0
R*O300M22	ZS21K4E	16.4	88.0	1.0	18.4	25.0	11.1	77.0	1.0	13.1	17.0	5.7	39.0	0.4	6.6	15.0
R*O301M22	ZS26K4E	20.7	109.0	1.0	22.7	30.0	13.6	88.0	1.0	15.6	20.0	7.1	44.0	0.4	8.0	15.0
R*O400M22	ZS30K4E	26.8	129.0	3.2	31.0	38.0	15.0	99.0	3.2	19.2	23.0	8.2	49.5	2.1	10.8	15.0
R*O600M22	ZS38K4E	31.8	169.0	3.2	36.0	44.0	21.4	123.0	3.2	25.6	31.0	9.6	62.0	2.1	12.2	15.0
R*O650M22	ZS45K4E	-----	-----	-----	-----	-----	23.9	156.0	3.2	28.1	34.0	9.3	70.0	2.1	11.9	15.0

DISCUS

R*D500H22	2DD-R63KE	-----	-----	-----	-----	-----	22.3	120.0	3.2	26.5	33	10.5	60.0	2.1	13.1	16
R*D300L22	2DF-F16KE	-----	-----	-----	-----	-----	16.8	102.0	3.2	21.0	26	8.1	52.0	2.1	10.7	17
R*D400L22	2DL-F20KE	-----	-----	-----	-----	-----	26.3	161.0	3.2	30.5	38	10.2	60.0	2.1	12.8	22
R*D500L22	2DA-F23KE	-----	-----	-----	-----	-----	28.8	161.0	3.2	33.0	41	10.2	60.0	2.1	12.8	24

SEMI-HERMETIC

R*S075H22	KAN-0075	6.1	36.0	0.5	7.6	15	3.5	19.9	0.5	5.0	15	-----	-----	-----	-----	-----
R*S100H22	KAR-010E	7.4	40.0	0.5	8.9	15	4.3	27.0	0.5	5.8	15	-----	-----	-----	-----	-----
R*S150H22	KAG-0150	9.6	55.0	1.0	11.6	15	5.5	35.5	1.0	7.5	15	-----	-----	-----	-----	-----
R*S200H22	KAK-020E	10.6	55.0	1.0	12.6	17	6.8	50.0	1.0	8.8	15	-----	-----	-----	-----	-----
R*S300H22	ERF-0310	**17.0	86.0	1.0	20.0	25	11.7	82.0	1.0	13.7	18	6.4	41.0	0.4	7.3	15
R*S050L22	KAN-005E	3.6	24.0	0.5	5.1	15	-----	-----	-----	-----	-----	-----	-----	-----	-----	-----
R*S075L22	KAM-007E	5.6	36.0	0.5	7.1	15	3.2	19.9	0.5	4.7	15	-----	-----	-----	-----	-----
R*S100L22	KAJ-010E	6.9	40.0	0.5	8.4	15	4.5	27.0	0.5	6.0	15	-----	-----	-----	-----	-----
R*S200L22	KAK-021E	10.6	55.0	1.0	12.6	17	6.8	50.0	1.0	8.8	15	-----	-----	-----	-----	-----
R*S201L22	EAD-0200	**8.4	58.0	1.0	10.4	15	6.8	46.0	1.0	8.8	15	-----	-----	-----	-----	-----
R*S202L22	EAV-021E	14.7	102.0	1.0	16.7	22	7.4	50.0	1.0	9.4	15	-----	-----	-----	-----	-----
R*S300L22	LAH-032E	**16.6	93.0	1.0	18.6	24	10.7	82.0	1.0	12.7	17	6.0	56.0	0.4	6.9	15

** This compressor is rated for 230/1/60 application only. Use Buck Boost transformer for 208/1 V.

† Total Unit Amps includes approximate allowance for control circuit as follows: 1A - 208/230V; 0.5A - 460V.

‡ MCA Minimum Circuit Ampacity does not include evaporator(s) electrical requirements. (Evaporator fan motor amps, defrost heater amps)

ELECTRICAL DATA / R-404A

MODEL NUMBER	COMP. MODEL NUMBER	AMPS @ 208/230/1/60					AMPS @ 208/230/3/60					AMPS @ 460/3/60				
		COMPRESSOR		COND	TOTAL	MCA	COMPRESSOR		COND	TOTAL	MCA	COMPRESSOR		COND	TOTAL	MCA
		RLA	LRA	FLA	UNIT†	‡	RLA	LRA	FLA	UNIT†	‡	RLA	LRA	FLA	UNIT†	‡
R*H055M44	RST45C1E	4.6	26.5	0.5	6.1	15	---	---	---	---	---	---	---	---	---	---
R*H080M44	RST55C1E	6.1	33.7	0.5	7.6	15	---	---	---	---	---	---	---	---	---	---
R*H090M44	RST64C1E	8.0	43.0	0.5	9.5	15	---	---	---	---	---	---	---	---	---	---
R*H100M44	RS70C1E	6.3	34.2	0.5	7.8	15	4.2	31.0	0.5	5.7	15	2.4	15.0	0.4	3.3	15
R*H125M44	RS97C1E	9.9	51.0	1.0	11.9	15	6.3	35.0	1.0	8.3	15	---	---	---	---	---
R*H151M44	CS10K6E	9.8	56.0	1.0	11.8	15	6.7	51.0	1.0	8.7	15	3.2	25.0	0.8	4.5	15
R*H200M44	CS12K6E	9.8	56.0	1.0	11.8	15	6.7	51.0	1.0	8.7	15	---	---	---	---	---
R*H251M44	CS14K6E	11.2	61.0	1.0	13.2	16	8.2	55.0	1.0	10.2	15	4.2	28.0	0.8	5.5	15
R*H301M44	CS18K6E	14.4	82.0	1.0	16.4	20	7.9	65.5	1.0	9.9	15	4.2	33.0	0.8	5.5	15
R*H325M44	CS20K6E	16.7	96.0	1.0	18.7	23	10.2	75.0	1.0	12.2	15	4.6	40.0	0.8	5.9	15
R*H400M44	CS27K6E	21.5	121.0	3.1	25.6	31	12.1	105.0	3.1	16.2	20	7.6	52.0	1.1	9.2	15
R*H500M44	CS33K6E	27.6	125.0	3.1	31.7	39	16.8	102.0	3.1	20.9	26	8.8	48.0	1.1	10.4	15
R*H055H44	RST45C1E	4.6	26.5	0.5	6.1	15	---	---	---	---	---	---	---	---	---	---
R*H090H44	RST64C1E	8.0	43.0	0.5	9.5	15	---	---	---	---	---	---	---	---	---	---
R*H100H44	RS70C1E	6.9	34.2	0.5	8.4	15	4.7	31.0	0.5	6.2	15	---	---	---	---	---
R*H151H44	CS10K6E	11.1	56.0	1.0	13.1	16	7.2	51.0	1.0	9.2	15	---	---	---	---	---
R*H251H44	CS14K6E	12.4	61.0	1.0	14.4	18	8.5	55.0	1.0	10.5	15	---	---	---	---	---
R*H325H44	CS20K6E	17.9	96.0	3.1	22	27	13.3	75.0	3.1	17.4	21	---	---	---	---	---
R*H400H44	CS27K6E	23.7	121.0	3.1	27.8	34	14.1	105.0	3.1	18.2	22	---	---	---	---	---
R*H500H44	CS33K6E	30.1	125.0	3.1	34.2	42	16.5	102.0	3.1	20.6	25	---	---	---	---	---
R*H075L44	RS70C1E	7.0	34.2	0.5	8.5	15	4.7	31.0	0.5	6.2	15	----	----	----	----	----
R*H100L44	RS97C1E	11.0	51.0	0.5	12.5	16	7.0	35.0	0.5	8.5	15	----	----	----	----	----
R*H165L44	CF06K6E	11.4	59.2	1.0	13.4	18	7.0	52.0	1.0	9.0	15	----	----	----	----	----
R*H215L44	CF09K6E	16.7	87.0	1.0	18.7	24	10.2	72.0	1.0	12.2	16	----	----	----	----	----
R*H315L44	CF12K6E	20.5	105.0	1.0	22.5	28	12.3	85.0	1.0	14.3	18	6.6	42.0	0.4	7.5	15
R*S100M44	KAR-010E	6.4	40.0	0.5	7.9	15	3.8	27.0	0.5	5.3	15	1.8	15.0	0.4	2.7	15
R*S200M44	KAK-020E	9.1	55.0	1.0	11.1	15	5.8	50.0	1.0	7.8	15	----	----	----	----	----
R*S250M44	ERC-021E	-----	-----	-----	-----	-----	7.9	46.0	1.0	9.9	15	3.1	23.0	0.8	4.4	15
R*S300M44	ERF-031E	15.3	86.0	1.0	17.3	22	11.2	82.0	1.0	13.2	16	5.2	41.0	0.8	6.5	15
R*S050L44	KAN-005E	3.6	24.0	0.5	5.1	15	2.2	13.2	0.5	3.7	15	----	----	----	----	----
R*S075L44	KAM-007E	5.6	35.0	0.5	7.1	15	3.2	19.9	0.5	4.7	15	----	----	----	----	----
R*S100L44	KAJ-010E	6.9	40.0	0.5	8.4	15	4.5	27.0	0.5	6.0	15	----	----	----	----	----
R*S150L44	KAL-016E	9.9	55.0	1.0	11.9	16	6.6	50.0	1.0	8.6	15	----	----	----	----	----
R*S200L44	EAV-021E	14.7	102.0	1.0	16.7	22	7.4	50.0	1.0	9.4	15	----	----	----	----	----
R*S300L44**	LAH-032E	16.7	105.0	1.0	19.7	24	12.8	112.0	1.0	14.8	19	6.0	56.0	0.4	6.9	15
R*O200M44	ZS15K4E	13.6	55.0	1.0	15.6	20.0	9.3	55.0	1.0	11.3	15.0	4.3	27.0	0.4	5.2	15.0
R*O250M44	ZS19K4E	16.4	73.0	1.0	18.4	25.0	9.7	63.0	1.0	11.7	15.0	5.0	31.0	0.4	5.9	15.0
R*O315M44	ZS21K4E	16.4	88.0	3.2	20.6	25.0	11.1	77.0	3.2	15.3	17.0	5.7	39.0	2.1	8.3	15.0
R*O350M44	ZS26K4E	20.7	109.0	3.2	24.9	30.0	13.6	88.0	3.2	17.8	20.0	7.1	44.0	2.1	9.7	15.0
R*O400M44	ZS30K4E	26.8	129.0	3.2	31.0	38.0	15.0	99.0	3.2	19.2	23.0	8.2	49.5	2.1	10.8	15.0
R*O600M44	ZS38K4E	31.8	169.0	3.2	36.0	44.0	21.4	123.0	3.2	25.6	31.0	9.6	62.0	2.1	12.2	15.0
R*O650M44	ZS45K4E	-----	-----	-----	-----	-----	23.9	156.0	3.2	28.1	34.0	9.3	70.0	2.1	11.9	15.0
R*O200L44	ZF06K4E	13.6	55.0	1.0	15.6	20.0	9.3	55.0	1.0	11.3	16.0	4.3	27.0	0.4	5.2	15.0
R*O250L44	ZF08K4E	16.4	73.0	1.0	18.4	25.0	9.7	63.0	1.0	11.7	16.0	5.0	31.0	0.4	5.9	15.0
R*O300L44	ZF09K4E	16.4	88.0	1.0	18.4	25.0	11.1	77.0	1.0	13.1	17.0	5.7	39.0	0.4	6.6	15.0
R*O301L44	ZF11K4E	20.7	109.0	1.0	22.7	30.0	13.6	88.0	1.0	15.6	20.0	7.1	44.0	0.4	8.0	15.0
R*O400L44	ZF13K4E	26.8	129.0	3.2	31.0	38.0	15.0	99.0	3.2	19.2	23.0	8.2	57.0	2.1	10.8	19.0
R*O500L44	ZF15K4E	31.5	169.0	3.2	35.7	44.0	21.4	123.0	3.2	25.6	31.0	9.6	62.0	2.1	12.2	23.0
R*O600L44	ZF18K4E	-----	-----	-----	-----	-----	23.9	156.0	3.2	28.1	34.0	9.3	70.0	2.1	11.9	23.0
R*D500M44	2DD-R63KE	-----	-----	-----	-----	-----	22.3	120.0	3.2	26.5	33	10.5	60.0	1.1	12.1	16
R*D600M44	2DL-R78KE	-----	-----	-----	-----	-----	31.6	169.0	3.2	35.8	44	13.8	85.0	1.1	15.4	20
R*D300L44	2DF-F16KE	-----	-----	-----	-----	-----	16.8	102.0	3.1	20.9	26	8.1	52.0	1.1	9.7	17
R*D400L44	2DL-F20KE	-----	-----	-----	-----	-----	26.3	161.0	3.1	30.4	38	10.2	60.0	1.1	11.8	22
R*D500L44	2DA-F23KE	-----	-----	-----	-----	-----	28.8	161.0	3.1	32.9	41	10.2	60.0	1.1	11.8	24

** This compressor is rated for **230/1/60 application only**. Use Buck Boost transformer for 208/1 V.
† Total Unit Amps includes approximate allowance for control circuit as follows: 1A - 208/230V; 0.5A - 460V.
‡ MCA Minimum Circuit Ampacity does not include evaporator(s) electrical requirements. (Evaporator fan motor amps, defrost heater amps)

SPECIFICATIONS / R-404A

MODEL NUMBER	COMPRESSOR	NOM. HP	REC'R @ 90% R-404a (LBS)	CONN. (ODS, IN.)		FIG	Dimensions (in.)			APPROX. SHIP WT. (lbs.)	Sound Data dbA†
				LIQ.	SUC.		L	W	H		
R*H055M44	RST45C1E	0.50	5.1	3/8	5/8	A	28-1/4	27-3/4	17-1/4	152	68
R*H080M44	RST55C1E	0.75	5.1	3/8	5/8	A	28-1/4	27-3/4	17-1/4	152	68
R*H090M44	RST64C1E	0.75	5.1	3/8	5/8	A	28-1/4	27-3/4	17-1/4	160	68
R*H100M44	RS70C1E	1.00	5.1	3/8	5/8	A	28-1/4	27-3/4	17-1/4	167	68
R*H125M44	RS97C1E	1.25	8.6	3/8	5/8	B	28-1/4	38-1/4	17-1/4	195	72
R*H151M44	CS10K6E	1.50	8.6	3/8	7/8	B	28-1/4	38-1/4	17-1/4	205	72
R*H200M44	CS12K6E	2.00	8.6	3/8	7/8	B	28-1/4	38-1/4	17-1/4	228	72
R*H251M44	CS14K6E	2.50	8.6	3/8	7/8	B	28-1/4	38-1/4	17-1/4	235	72
R*H301M44	CS18K6E	3.00	8.6	3/8	7/8	C	28-1/4	38-1/4	20-1/4	253	75
R*H325M44	CS20K6E	3.00	13.7	1/2	1-1/8	C	28-1/4	38-1/4	20-1/4	273	75
R*H400M44	CS27K6E	4.00	24.3	1/2	1-1/8	D	33	42-1/4	32-1/4	390	73
R*H500M44	CS33K6E	5.00	24.3	1/2	1-1/8	D	33	42-1/4	32-1/4	405	73
R*H055H44	RST45C1E	0.50	5.1	3/8	5/8	A	28-1/4	27-3/4	17-1/4	165	68
R*H090H44	RST64C1E	0.75	5.1	3/8	5/8	A	28-1/4	27-3/4	17-1/4	173	68
R*H100H44	RS70C1E	1.00	5.1	3/8	5/8	A	28-1/4	27-3/4	17-1/4	180	68
R*H151H44	CS10K6E	1.50	8.6	3/8	7/8	B	28-1/4	38-1/4	17-1/4	221	72
R*H251H44	CS14K6E	2.50	8.6	3/8	7/8	B	28-1/4	38-1/4	17-1/4	253	72
R*H325H44	CS20K6E	3.00	13.7	1/2	1-1/8	D	33	42-1/4	32-1/4	297	75
R*H400H44	CS27K6E	4.00	24.3	1/2	1-1/8	D	33	42-1/4	32-1/4	416	73
R*H500H44	CS33K6E	5.00	24.3	1/2	1-1/8	D	33	42-1/4	32-1/4	433	73
R*H075L44	RS70C1E	0.75	5.1	3/8	5/8	A	28-1/4	27-3/4	17-1/4	157	68
R*H100L44	RS97C1E	1.00	5.1	3/8	5/8	A	28-1/4	27-3/4	17-1/4	180	68
R*H165L44	CF06K6E	1.50	8.6	3/8	7/8	B	28-1/4	27-3/4	17-1/4	195	74
R*H215L44	CF09K6E	2.00	8.6	3/8	7/8	B	28-1/4	27-3/4	17-1/4	243	75
R*H315L44	CF12K6E	3.00	13.7	1/2	1-1/8	C	28-1/4	38-1/4	20-1/4	255	77
R*S100M44	KAR-010E	1.00	5.1	3/8	5/8	A	28-1/4	27-3/4	17-1/4	205	65
R*S200M44	KAK-020E	2.00	8.6	3/8	7/8	B	28-1/4	38-1/4	17-1/4	270	70
R*S250M44	ERC-021E	2.50	8.6	1/2	1-1/8	B	28-1/4	38-1/4	17-1/4	360	70
R*S300M44	ERF-031E	3.00	24.3	1/2	1-1/8	D	33	42-1/4	32-1/4	415	70
R*S050L44	KAN-005E	0.50	5.1	3/8	5/8	A	28-1/4	27-3/4	17-1/4	189	67
R*S075L44	KAM-007E	0.75	5.1	3/8	5/8	A	28-1/4	27-3/4	17-1/4	205	67
R*S100L44	KAJ-010E	1.00	5.1	3/8	5/8	A	28-1/4	27-3/4	17-1/4	220	67
R*S150L44	KAL-016E	1.50	8.6	3/8	7/8	B	28-1/4	38-1/4	17-1/4	248	70
R*S200L44	EAV-021E	2.00	8.6	3/8	7/8	B	28-1/4	38-1/4	17-1/4	290	70
R*S300L44	LAH-032E	3.00	13.7	1/2	1-1/8	C	28-1/4	38-1/4	20-1/4	383	70
R*O200M44	ZS15K4E	2.00	13.7	1/2	7/8	C	28-1/4	38-1/4	20-1/4	215	71
R*O250M44	ZS19K4E	2.50	13.7	1/2	1-1/8	C	28-1/4	38-1/4	20-1/4	230	72
R*O315M44	ZS21K4E	3.00	13.7	1/2	1-1/8	D	33	42-1/4	32-1/4	315	74
R*O350M44	ZS26K4E	3.50	13.7	1/2	1-1/8	D	33	42-1/4	32-1/4	335	74
R*O400M44	ZS30K4E	4.00	24.3	1/2	1-1/8	D	33	42-1/4	32-1/4	352	74
R*O600M44	ZS38K4E	6.00	24.3	1/2	1-1/8	D	33	42-1/4	32-1/4	383	74
R*O650M44	ZS45K4E	6.50	24.3	5/8	1-1/8	D	33	42-1/4	32-1/4	405	76
R*O200L44	ZF06K4E	2.00	13.7	1/2	7/8	C	28-1/4	38-1/4	20-1/4	230	71
R*O250L44	ZF08K4E	2.50	13.7	1/2	7/8	C	28-1/4	38-1/4	20-1/4	240	73
R*O300L44	ZF09K4E	3.00	13.7	1/2	1-1/8	C	28-1/4	38-1/4	20-1/4	245	73
R*O301L44	ZF11K4E	3.00	13.7	1/2	1-1/8	C	28-1/4	38-1/4	20-1/4	255	73
R*O400L44	ZF13K4E	4.00	24.3	1/2	1-1/8	D	33	42-1/4	32-1/4	352	74
R*O500L44	ZF15K4E	5.00	24.3	1/2	1-1/8	D	33	42-1/4	32-1/4	367	74
R*O600L44	ZF18K4E	6.00	24.3	1/2	1-1/8	D	33	42-1/4	32-1/4	383	76
R*D500M44	2DD-R63KE	5.00	24.3	1/2	1-1/8	D	33	42-1/4	32-1/4	630	78
R*D600M44	2DL-R78KE	6.00	24.3	5/8	1-1/8	D	33	42-1/4	32-1/4	630	78
R*D300L44	2DF-F16KE	3.00	24.3	1/2	1-1/8	D	33	42-1/4	32-1/4	575	78
R*D400L44	2DL-F20KE	4.00	24.3	1/2	1-1/8	D	33	42-1/4	32-1/4	600	78
R*D500L44	2DA-F23KE	5.00	24.3	1/2	1-1/8	D	33	42-1/4	32-1/4	620	78

† Estimated dbA values at 10 feet from the unit. Correction factors: Deduct 6 dbA. for 20 to 40 feet, 12 dbA @ 40 to 60 feet. Ratings at the outlet of the discharge air. The actual measurements may vary depending upon installation variables. Environmental factors may have a significant influence on this data.

See page 15 for dimensional drawings.

SPECIFICATIONS R-22

MODEL NUMBER	COMPRESSOR	NOM. HP	REC'R @ 90% R-22 (LBS)	CONN. (ODS, IN.)		FIG	Dimensions (in.)			APPROX. SHIP WT. (lbs.)	Sound Data dbA†
				LIQ.	SUC.		L	W	H		
R*H051H22	ART82C1	1/2	6.0	3/8	5/8	A	28-1/4	26-1/4	17-1/4	170	68
R*H075H22	RSE-0075	3/4	6.0	3/8	5/8	A	28-1/4	26-1/4	17-1/4	175	68
R*H100H22	RS70CE	3/4	6.0	3/8	5/8	A	28-1/4	26-1/4	17-1/4	180	68
R*H151H22	CR18KQ	1.5	10.0	3/8	7/8	B	28-1/4	38-1/4	17-1/4	210	72
R*H201H22	CR24KQ	2.0	10.0	3/8	7/8	C	28-1/4	38-1/4	20-1/4	223	72
R*H251H22	CR33KQ	2.5	16.0	1/2	7/8	C	28-1/4	38-1/4	20-1/4	245	72
R*H301H22	CR41KQ	3.0	16.0	1/2	7/8	C	28-1/4	38-1/4	20-1/4	260	72
R*H401H22	CR53KQ	4.0	28.2	1/2	7/8	D	33	42-1/4	32-1/4	348	73
R*H500H22	CRN-0500	5.0	28.2	1/2	7/8	D	33	42-1/4	32-1/4	380	75
R*S075H22	KAN-0075	3/4	6.0	3/8	5/8	A	28-1/4	26-1/4	17-1/4	215	66
R*S100H22	KAR-010E	1.5	6.0	3/8	5/8	A	28-1/4	26-1/4	17-1/4	220	66
R*S150H22	KAG-0150	2.0	10.0	3/8	7/8	B	28-1/4	38-1/4	17-1/4	247	70
R*S200H22	KAK-020E	2.5	10.0	3/8	7/8	B	28-1/4	38-1/4	17-1/4	260	70
R*S300H22	ERF-0310	3.0	16.0	1/2	1-1/8	C	28-1/4	38-1/4	20-1/4	420	70
R*S050L22	KAN-005E	1/2	6.0	3/8	5/8	A	28-1/4	26-1/4	17-1/4	192	65
R*S075L22	KAM-007E	3/4	6.0	3/8	5/8	A	28-1/4	26-1/4	17-1/4	197	65
R*S100L22	KAJ-010E	1.0	6.0	3/8	5/8	A	28-1/4	26-1/4	17-1/4	205	66
R*S200L22	KAK-021E	2.0	10.0	3/8	7/8	B	28-1/4	38-1/4	17-1/4	290	70
R*S201L22	EAD-0200	2.0	10.0	3/8	7/8	B	28-1/4	38-1/4	17-1/4	320	70
R*S202L22	EAV-021E	2.0	10.0	3/8	7/8	B	28-1/4	38-1/4	17-1/4	330	70
R*S300L22	LAH-032E	3.0	16.0	1/2	1-1/8	C	28-1/4	38-1/4	20-1/4	412	71
R*O200M22	ZS15K4E	2.0	16.0	1/2	7/8	C	28-1/4	38-1/4	20-1/4	215	71
R*O250M22	ZS19K4E	2.5	16.0	1/2	1-1/8	C	28-1/4	38-1/4	20-1/4	230	72
R*O300M22	ZS21K4E	3.0	16.0	1/2	1-1/8	C	28-1/4	38-1/4	20-1/4	305	72
R*O301M22	ZS26K4E	3.0	16.0	1/2	1-1/8	C	28-1/4	38-1/4	20-1/4	325	72
R*O400M22	ZS30K4E	4.0	28.2	1/2	1-1/8	D	33	42-1/4	32-1/4	352	74
R*O600M22	ZS38K4E	6.0	28.2	1/2	1-1/8	D	33	42-1/4	32-1/4	383	74
R*O650M22	ZS45K4E	6.5	28.2	5/8	1-1/8	D	33	42-1/4	32-1/4	405	76
R*D500H22	2DD-R63KE	5.0	28.2	1/2	1-1/8	D	33	42-1/4	32-1/4	630	78
R*D300L22	2DF-F16KE	3.0	28.2	1/2	1-1/8	D	33	42-1/4	32-1/4	575	78
R*D400L22	2DL-F20KE	4.0	28.2	1/2	1-1/8	D	33	42-1/4	32-1/4	600	78
R*D500L22	2DA-F23KE	5.0	28.2	1/2	1-1/8	D	33	42-1/4	32-1/4	620	78

† Estimated dbA values at 10 feet from the unit. Correction factors: Deduct 6 dbA. for 20 to 40 feet, 12 dbA @ 40 to 60 feet.
Ratings at the outlet of the discharge air. The actual measurements may vary depending upon installation variables.
Environmental factors may have a significant influence on this data.

Physical Dimensions - All Models

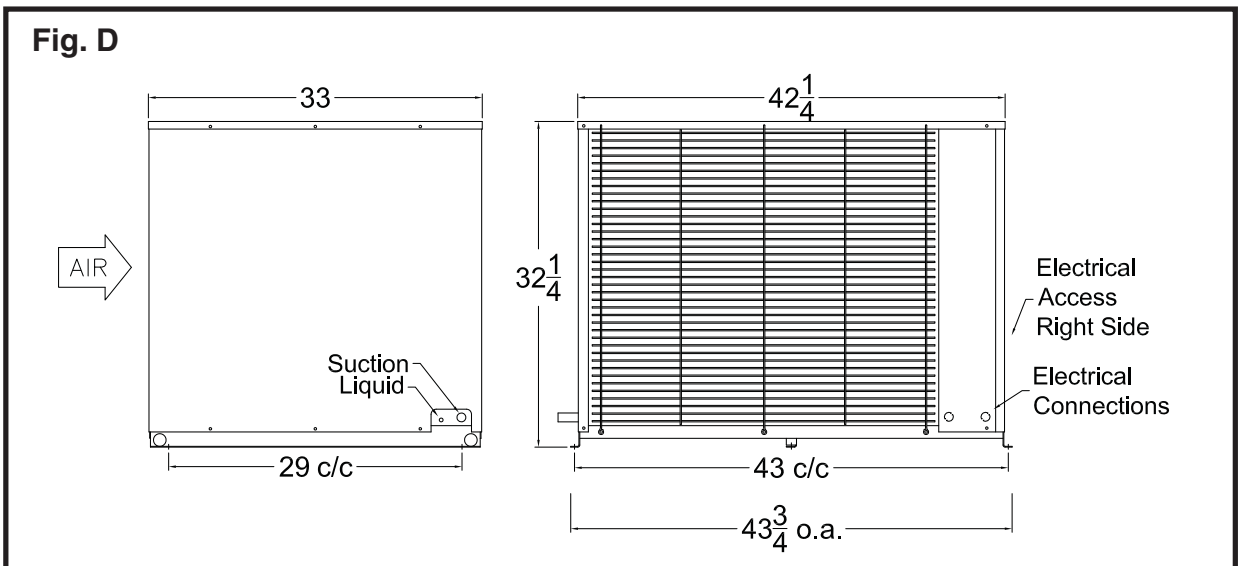
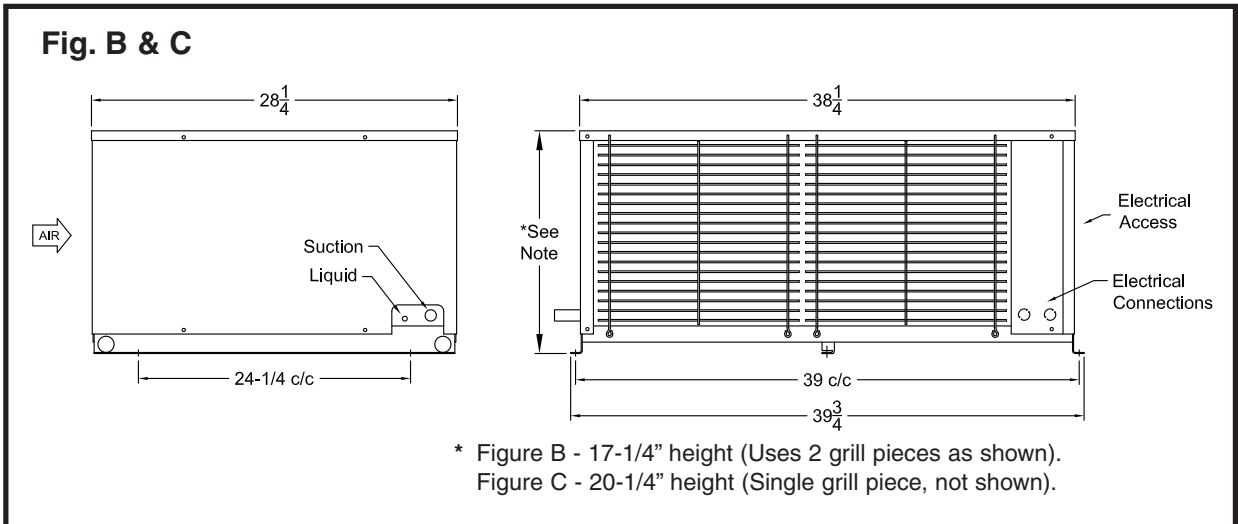
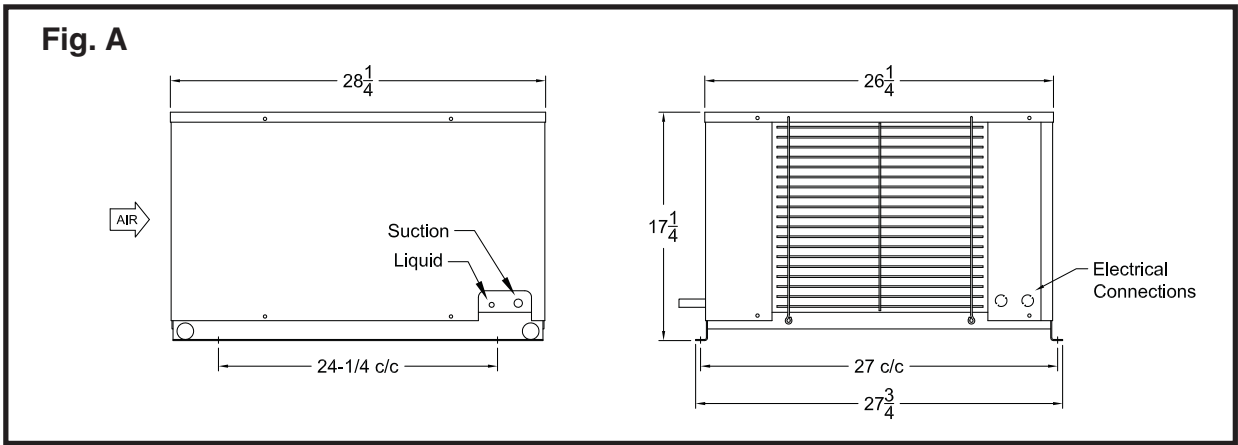

Contact your Russell Sales Representative or visit our website to learn about other quality products that are available to meet your refrigeration needs.

9 styles of Reach-in / Under counter units



3 HP to 80 HP condensing units



Walk-in / Warehouse evaporators

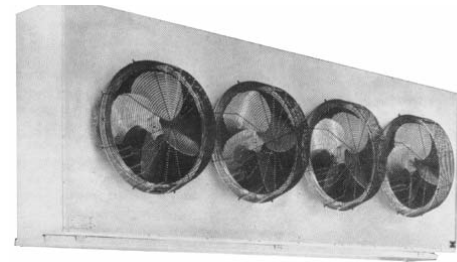
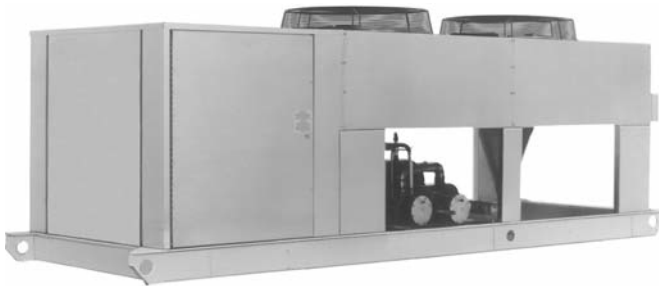

Remote Compressor Units and Air Cooled Condensers

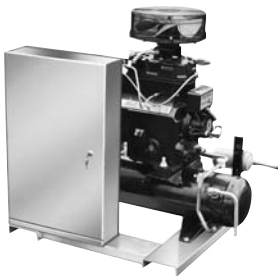

Due to ongoing product development, specifications are subject to change without notice.