

RUSSELL

COIL COMPANY

AIR COOLED CONDENSERS

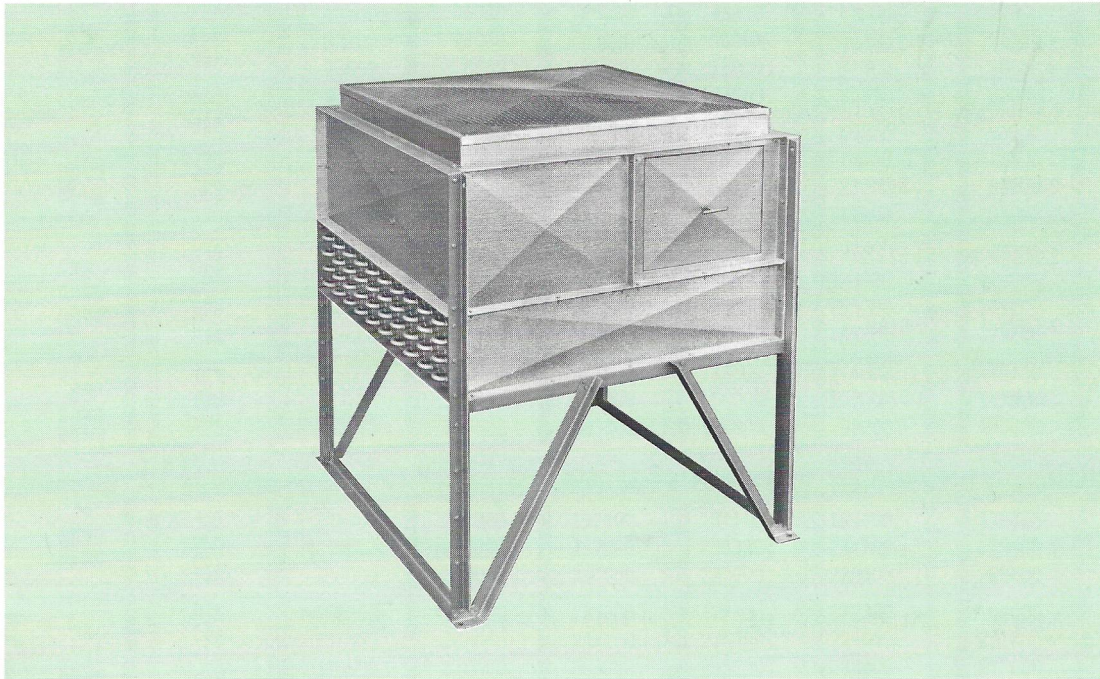

MODEL BDVD (Belt driven vertical discharge)

RUSSELL BD MODELS

in either the Model BDVD (belt driven vertical air discharge as show in photo) or in the Model BDHD (belt driven horizontal discharge). Capacities range from 5 HP through 70 HP with provision for multi-circuiting at no additional cost. Models 40 through 70 are twin units, interconnected at the job site.

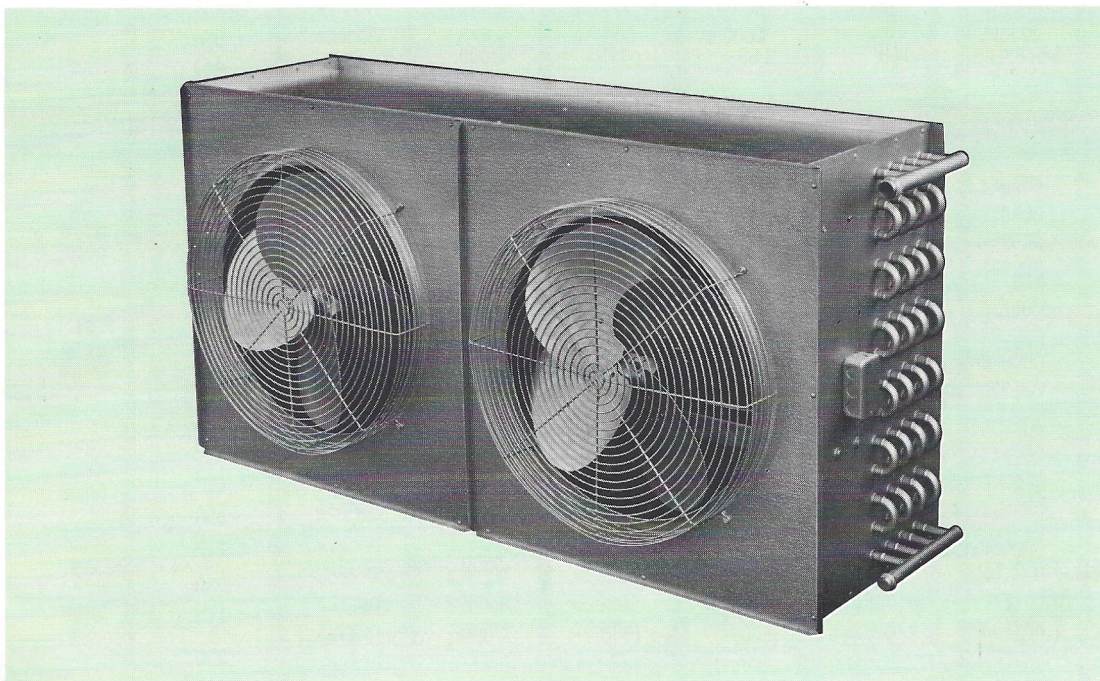

MODEL RAC (Direct drive)

RUSSELL MODEL RAC

available with horizontal or vertical discharge. Capacities range from $\frac{3}{4}$ HP through 10 HP. Multi-circuiting available at no additional cost on RAC-5 through RAC-10.

GENERAL DATA FOR BELT DRIVEN AND DIRECT DRIVE UNITS

BELT-DRIVEN FAN UNITS

MODELS	TONS 40° SUCT. 30° TD	INLET OD INS.	OUTLET OD INS.	FAN DIA. INS.	FAN RPM	CFM	FAN MOTOR		
							HP	VOLT	Ø
5 BDVD BDHD	5.25	1-1/8"	7/8"	30	575	5700	1/3	115 230	1
7-1/2 BDVD BDHD	7.66	1-3/8"	1-1/8"	36	570	7700	1/2	115 230	1
10 BDVD BDHD	10.0	1-5/8"	1-3/8"	36	630	9000	1	220 440	3
16 BDVD BDHD	16.65	2-1/8"	1-3/8"	48	450	15000	1-1/2	220 440	3
20 BDVD BDHD	20.60	2-1/8"	1-5/8"	48	460	16000	1-1/2	220 440	3
25 BDVD BDHD	25.20	2-1/8"	1-5/8"	60	420	23000	2	220 440	3
30 BDVD BDHD	31.00	2-5/8"	1-5/8"	60	450	25000	3	220 440	3
35 BDVD BDHD	35.00	2-5/8"	1-5/8"	60	495	30000	3	220 440	3

*BELT-DRIVEN TWIN UNITS — [Two smaller units interconnected at job-site]

32 BDVD BDHD	33.30	3-1/8"	2-1/8"	2-48	450	30000	2—1-1/2	220 440	3
40 BDVD BDHD	41.2	3-1/8"	2-1/8"	2-48	460	32000	2—1-1/2	220 440	3
50 BDVD BDHD	50.40	3-1/8"	2-1/8"	2-60	420	46000	2-2	220 440	3
60 BDVD BDHD	62.00	3-5/8"	2-1/8"	2-60	450	50000	2-3	220 440	3
70 BDVD BDHD	70.00	3-5/8"	2-1/8"	2-60	495	60000	2-3	220 440	3

DIRECT-DRIVE UNITS [Horizontal or vertical discharge 5 HP thru 10 HP]

3/4 RAC H-ONLY	0.87	5/8	1/2	14	1050	760	1/12	115 or 230	1
1 RAC H-ONLY	1.12	5/8	1/2	16	1050	1210	1/12	115 or 230	1
1-1/2 RAC H-ONLY	1.63	5/8	1/2	20	1050	1850	1/6	115 or 230	1
2 RAC H-ONLY	2.08	5/8	1/2	20	1050	2500	1/6	115 or 230	1
3 RAC H-ONLY	3.04	3/4	5/8	20	1050	2800	1/6	115 or 230	1
5 RACV RACH	5.17	1-1/8	7/8	2-20	1050	5500	2-1/6	115 or 230	1
7-1/2 RACV RACH	7.55	1-1/8	7/8	2-20	1050	7000	2-1/6	115 or 230	1
10 RACV RACH	10.00	1-1/8	7/8	3-20	1050	9050	3-1/6	115 or 230	1

*Manifold assembly included in price of unit.

Specifications subject to change without notice.

GENERAL DATA FOR BELT DRIVEN AND DIRECT DRIVE UNITS

BELT-DRIVEN FAN UNITS

MODELS	TONS 40° SUCT. 30° TD	INLET OD INS.	OUTLET OD INS.	FAN DIA. INS.	FAN RPM	CFM	FAN MOTOR		
							HP	VOLT	Ø
5 BDVD BDHD	5.25	1-1/8"	7/8"	30	575	5700	1/3	115 230	1
7-1/2 BDVD BDHD	7.66	1-3/8"	1-1/8"	36	570	7700	1/2	115 230	1
10 BDVD BDHD	10.0	1-5/8"	1-3/8"	36	630	9000	1	220 440	3
16 BDVD BDHD	16.65	2-1/8"	1-3/8"	48	450	15000	1-1/2	220 440	3
20 BDVD BDHD	20.60	2-1/8"	1-5/8"	48	460	16000	1-1/2	220 440	3
25 BDVD BDHD	25.20	2-1/8"	1-5/8"	60	420	23000	2	220 440	3
30 BDVD BDHD	31.00	2-5/8"	1-5/8"	60	450	25000	3	220 440	3
35 BDVD BDHD	35.00	2-5/8"	1-5/8"	60	495	30000	3	220 440	3

*BELT-DRIVEN TWIN UNITS — [Two smaller units interconnected at job-site]

32 BDVD BDHD	33.30	3-1/8"	2-1/8"	2-48	450	30000	2—1-1/2	220 440	3
40 BDVD BDHD	41.2	3-1/8"	2-1/8"	2-48	460	32000	2—1-1/2	220 440	3
50 BDVD BDHD	50.40	3-1/8"	2-1/8"	2-60	420	46000	2-2	220 440	3
60 BDVD BDHD	62.00	3-5/8"	2-1/8"	2-60	450	50000	2-3	220 440	3
70 BDVD BDHD	70.00	3-5/8"	2-1/8"	2-60	495	60000	2-3	220 440	3

DIRECT-DRIVE UNITS [Horizontal or vertical discharge 5 HP thru 10 HP]

3/4 RAC H-ONLY	0.87	5/8	1/2	14	1050	760	1/12	115 or 230	1
1 RAC H-ONLY	1.12	5/8	1/2	16	1050	1210	1/12	115 or 230	1
1-1/2 RAC H-ONLY	1.63	5/8	1/2	20	1050	1850	1/6	115 or 230	1
2 RAC H-ONLY	2.08	5/8	1/2	20	1050	2500	1/6	115 or 230	1
3 RAC H-ONLY	3.04	3/4	5/8	20	1050	2800	1/6	115 or 230	1
5 RACV RACH	5.17	1-1/8	7/8	2-20	1050	5500	2-1/6	115 or 230	1
7-1/2 RACV RACH	7.55	1-1/8	7/8	2-20	1050	7000	2-1/6	115 or 230	1
10 RACV RACH	10.00	1-1/8	7/8	3-20	1050	9050	3-1/6	115 or 230	1

*Manifold assembly included in price of unit.

Specifications subject to change without notice.

CAPACITIES IN BTU/HR AT THE EVAPORATOR

BELT DRIVEN FAN UNITS

MODEL	T.D.	SUCTION TEMPERATURE								
		45°	40°	30°	20°	10°	0°	-10°	-20°	-30°
5 BDVD BDHD	15	31800	31500	30900	30000	29200	28100	26800	25500	24000
	20	42600	42000	41200	40000	38900	37500	35800	34000	32000
	25	53400	52500	51600	50000	48800	47000	45000	42500	40000
	30	63600	63000	61800	60000	58400	56200	53400	51000	48000
7½ BDVD BDHD	15	46500	46000	45000	43800	42600	41000	39000	37400	35100
	20	62200	61300	60100	58200	56800	54700	52300	49700	46700
	25	78000	76600	75400	73000	71300	68600	65700	62000	58600
	30	93000	92000	90200	87600	85200	82000	78000	74800	70200
10 BDVD BDHD	15	60600	60000	58800	57100	55500	53500	51000	48800	45800
	20	81000	80000	78400	75900	74000	71400	68200	64800	60900
	25	101700	100000	98400	95200	93000	89500	85700	81000	76400
	30	121200	120000	117600	114200	111000	107000	102000	97600	91600
16 BDVD BDHD	15	101000	100000	98000	95200	92600	89300	85000	81300	76300
	20	135000	133300	130700	126600	123500	119000	113600	108000	101500
	25	169500	167000	163900	158700	155000	149200	142800	135000	127400
	30	202000	200000	196000	190400	185200	178600	170000	162600	152600
20 BDVD BDHD	15	125000	124000	121500	118100	114800	110700	105000	100800	94600
	20	167500	165300	162100	156900	153000	147600	141000	134000	125900
	25	210200	206500	203300	196800	192200	185000	177000	167500	157900
	30	250500	248000	243100	236200	229600	221400	210000	201600	189200
25 BDVD BDHD	15	152500	151000	148000	143800	139800	134800	128000	122800	115300
	20	204000	201300	197400	191100	186400	179600	171600	163200	153300
	25	256000	251700	247500	239700	234100	225400	215700	204000	192300
	30	305000	302000	296000	287600	279600	269600	256000	245600	230600
30 BDVD BDHD	15	188000	186000	182300	177100	172200	166000	157500	151200	142000
	20	251300	248000	243100	235400	229600	221400	211300	201000	189000
	25	315500	310000	304900	295200	288400	277600	265700	251300	237000
	30	376000	372000	364500	354200	344400	332000	315000	302400	284000
35 BDVD BDHD	15	212000	210000	206000	200000	194000	187000	179000	171000	160000
	20	284000	280000	274000	266000	259000	250000	239000	227000	213000
	25	356000	350000	344000	333000	325000	313000	300000	284000	268000
	30	424000	420000	412000	400000	389000	375000	356000	342000	320000

BELT-DRIVEN TWIN UNITS

32 BDVD BDHD	15	202000	200000	196000	190400	185200	179600	170000	162600	152600
	20	270000	266600	261400	253200	247000	238000	227200	216000	203000
	25	339000	334000	327800	317400	310000	298400	285600	270000	254800
	30	404000	400000	392000	380800	370400	357200	340000	325200	305200
40 BDVD BDHD	15	250000	248000	243000	236200	229600	221400	210000	201600	189200
	20	335000	330600	324200	313800	306000	295200	282000	268000	251800
	25	420400	413000	406600	393600	384400	370000	354000	335000	315800
	30	501000	496000	486200	472400	459200	442800	420000	403200	378400
50 BDVD BDHD	15	305000	302000	296000	287600	279600	269600	256000	245600	230600
	20	408000	402600	394800	382200	372800	359200	343200	326400	306600
	25	512000	503400	495000	479400	468200	450800	431400	408000	384600
	30	610000	604000	592000	575200	558200	539200	512000	491200	461200
60 BDVD BDHD	15	376000	372000	364600	354200	344400	332000	315000	302400	284000
	20	502600	496000	486200	470800	458200	442800	422600	402000	378000
	25	631000	620000	609800	590400	576800	555200	531400	502600	474000
	30	752000	744000	729000	708400	688800	664000	630000	604800	568000
70 BDVD BDHD	15	424000	420000	412000	400000	388000	374000	358000	342000	320000
	20	568000	560000	548000	532000	518000	500000	478000	454000	426000
	25	712000	700000	688000	666000	650000	626000	600000	568000	536000
	30	848000	840000	824000	800000	778000	750000	712000	684000	640000

DIRECT-DRIVE UNITS CAPACITIES IN BTU/HR AT THE EVAPORATOR

MODEL	T.D.	SUCTION TEMPERATURE								
		45°	40°	30°	20°	10°	0°	-10°	-20°	-30°
RAC - 3/4	15	5300	5250	5150	5000	4900	4700	4500	4300	4000
	20	7100	7000	6900	6650	6500	6300	6000	5700	5300
	25	8900	8750	8600	8300	8100	7800	7500	7100	6700
	30	10600	10500	10300	10000	9700	9400	8900	8500	8100
RAC - 1	15	6820	6750	6620	6400	6250	6000	5750	5500	5150
	20	9100	9000	8800	8500	8300	8000	7700	7300	6850
	25	11450	11250	11100	10700	10500	10100	9650	9100	8600
	30	13650	13500	13200	12850	12500	12100	11400	10800	10600
RAC - 1 1/2	15	9900	9800	9600	9300	9100	8800	8300	8000	7500
	20	13250	13100	12800	12400	12100	11700	11100	10600	9950
	25	16600	16350	16700	15580	15200	14600	14000	13300	12500
	30	19800	19600	19200	18700	18150	17500	16600	16000	15000
RAC - 2	15	12650	12500	12250	11900	11600	11200	10600	10100	9550
	20	16900	16700	16350	15800	15450	14900	14200	13500	12700
	25	21200	20800	20500	19850	19400	18700	17900	16900	15900
	30	25250	25000	24600	23800	23150	22300	21200	20300	19100
RAC - 3	15	18450	18250	17900	17400	16900	16300	15500	14800	13900
	20	24700	24400	23850	23100	22500	21800	20700	19700	18500
	25	30900	30400	29900	29000	28300	27100	26100	24600	23200
	30	36900	36500	35800	34750	33800	32600	30900	29700	27800
RAC - 5	15	31300	31000	30400	29500	28700	27700	26400	25200	23650
	20	41900	41300	40500	39200	38300	36900	35200	33500	31500
	25	52500	51700	50800	49200	48100	47300	44300	41900	39500
	30	62700	62000	60800	59000	57400	55300	52500	50400	47300
RAC - 7 1/2	15	45700	45250	44400	43100	41900	40400	38500	36800	34600
	20	61100	60300	59200	57300	55900	53900	51500	48900	45900
	25	76700	75500	74200	71800	70100	67600	64600	61100	57700
	30	91500	90500	88700	86200	83800	80800	76700	73500	69000
RAC - 10	15	60600	60000	58800	57100	55500	53600	51000	48800	45800
	20	81000	80000	78400	76000	74000	71500	68200	64900	61000
	25	101700	100000	98200	95200	93000	89500	85700	81000	76500
	30	121300	120000	117700	114200	111000	107100	101700	97500	91500

N.B.: Ratings include allowance of 25% for heat of compression.

Specifications subject to change without notice.

R-12 OPERATING CHARGE—RUSSELL AIR-COOLED CONDENSERS

CONDENSER MODEL NUMBER	AMBIENT ABOVE 60° F.		AMBIENT BETWEEN 60° F. & 30° F.		AMBIENT BELOW 30° F.		MULTI-CIRCUITS AVAILABLE
	UNIT CHARGE	CHARGE PER AVAIL. MULTI-CIRC.	UNIT CHARGE	CHARGE PER AVAIL. MULTI-CIRC.	UNIT CHARGE	CHARGE PER AVAIL. MULTI-CIRC.	
RAC - 3/4	0.55	NOT AVAILABLE	2.42	NOT AVAILABLE	3.2	NOT AVAILABLE	NONE
RAC - 1	0.75	NOT AVAILABLE	3.40	NOT AVAILABLE	4.5	NOT AVAILABLE	NONE
RAC - 1 1/2	1.00	NOT AVAILABLE	4.50	NOT AVAILABLE	6.0	NOT AVAILABLE	NONE
RAC - 2	1.40	NOT AVAILABLE	6.20	NOT AVAILABLE	8.2	NOT AVAILABLE	NONE
RAC - 3	2.25	0.75	10.00	3.33	13.2	4.40	3
RAC - 5	4.22	0.70	19.50	3.26	26.0	4.33	6
RAC - 7 1/2	7.10	1.01	31.60	4.51	41.8	5.97	7
RAC - 10	9.40	1.34	42.0	6.00	55.5	7.94	7
5 BDVD - BDHD	4.60	0.77	20.4	3.40	27.0	4.50	6
7 1/2 BDVD - BDHD	7.40	0.74	33.0	3.30	43.5	4.35	10
10 BDVD - BDHD	9.85	1.40	44.0	6.30	58.0	8.30	7
16 BDVD - BDHD	14.30	0.96	63.5	4.23	84.0	5.60	15
20 BDVD - BDHD	18.95	1.26	84.0	5.60	111.5	7.44	15
25 BDVD - BDHD	21.60	1.20	96.5	5.35	128.0	7.12	18
30 BDVD - BDHD	28.40	1.58	126.0	7.00	167.0	9.28	18
35 BDVD - BDHD	32.00	1.78	142.0	7.90	188.0	10.45	18

NOTE: (1) Charges shown below 60° ambient presuppose use of a CPC valve in condenser discharge line.

(2) For R-22, multiply above values by 0.90; R-500 by 0.88; R-502 by 0.93.

(3) Operating charge of twin units is double that of the single unit. E.G. BDVD or BDHD 32 = 2 BD 16 units, etc.

DATA FOR MULTI-CIRCUITING BELT-DRIVEN CONDENSERS

CAPACITIES SHOWN ARE BTU/HR AT EVAPORATOR PER CIRCUIT AVAILABLE

MODEL	NUMBER MULTI-CIRCUITS AVAILABLE	T.D.	SUCTION TEMPERATURE								
			45°	40°	30°	20°	10°	0°	-10°	-20°	-30°
5 BDVD BDHD	6	15	5300	5250	5150	5000	4866	4683	4466	4250	4000
		20	7100	7000	6866	6666	6483	6250	5966	5666	5333
		25	8900	8750	8600	8333	8133	7833	7500	7083	6666
		30	10600	10500	10300	10000	9733	9367	8900	8500	8000
7½ BDVD BDHD	10	15	4650	4600	4500	4380	4260	4100	3900	3740	3510
		20	6220	6130	6010	5820	5680	5470	5230	4970	4670
		25	7800	7660	7540	7300	7130	6860	6570	6200	5860
		30	9300	9200	9020	8760	8520	8200	7800	7480	7020
10 BDVD BDHD	7	15	8657	8571	8400	8157	7929	7643	7283	6971	6543
		20	11571	11429	11200	10843	10571	10200	9743	9257	8700
		25	14528	14286	14057	13600	13286	12786	12243	11571	10914
		30	17314	17143	16800	16314	15857	15286	14571	13943	13086
16 BDVD BDHD	15	15	6733	6667	6533	6347	6173	5953	5667	5420	5087
		20	9000	8887	8713	8440	8233	7933	7573	7200	6767
		25	11300	11133	10927	10580	10333	9946	9520	9000	8493
		30	13466	13333	13067	12693	12347	11907	11333	10840	10173
20 BDVD BDHD	15	15	8333	8267	8100	7873	7653	7380	7000	6720	6307
		20	11167	11020	10807	10460	10200	9840	9400	8933	8393
		25	14013	13766	13553	13120	12813	12333	11800	11167	10527
		30	16700	16533	16207	15747	15307	14760	14000	13440	12613
25 BDVD BDHD	18	15	8472	8389	8222	7989	7767	7489	7111	6822	6406
		20	11333	11183	10967	10616	10356	9978	9533	9066	8517
		25	14222	13983	13750	13317	13006	12522	11983	11333	10683
		30	16944	16777	16444	15978	15533	14978	14222	13644	12811
30 BDVD BDHD	18	15	10444	10333	10128	9838	9567	9222	8750	8400	7889
		20	13961	13778	13506	13078	12755	12300	11739	11167	10500
		25	17528	17222	16939	16400	16022	15422	14761	13961	13167
		30	20889	20667	20250	19678	19133	18444	17500	16800	15778
35 BDVD BDHD	18	15	11778	11667	11444	11111	10778	10389	9944	9500	8889
		20	15778	15556	15222	14778	14389	13889	13278	12611	11833
		25	19778	19444	19111	18500	18056	17389	16667	15778	14889
		30	23556	23333	22889	22222	21611	20833	19778	19000	17778

DATA FOR MULTI-CIRCUITING RAC DIRECT-DRIVE CONDENSERS

CAPACITIES SHOWN ARE BTU/HR AT EVAPORATOR, PER CIRCUIT AVAILABLE

MODEL	NUMBER MULTI-CIRCUITS AVAILABLE	T.D.	45°	40°	30°	20°	10°	0°	-10°	-20°	-30°
RAC - 3	3	15	6150	6083	5967	5800	5633	5433	5166	4933	4633
		20	8233	8133	7950	7700	7500	7267	6900	6566	6166
		25	10300	10133	9967	9667	9433	9033	8700	8200	7733
		30	12300	12200	11900	11600	11300	10900	10300	9900	9300
RAC - 5	6	15	5200	5767	5067	4917	4783	4617	4400	4200	3942
		20	6983	6883	6750	6533	6383	6150	5867	5583	5250
		25	8750	8617	8467	8200	8017	7883	7383	6983	6583
		30	10450	10333	10133	9833	9567	9217	8750	8400	7883
RAC - 7½	7	15	6529	6464	6343	6157	5986	5771	5500	5257	4943
		20	8729	8614	8457	8186	7986	7700	7357	6986	6557
		25	10957	10786	10600	10257	10014	9657	9229	8729	8243
		30	13071	12929	12671	12314	11971	11523	10957	10500	9857
RAC - 10	7	15	8657	8571	8400	8157	7929	7657	7286	6971	6543
		20	11571	11429	11200	10857	10571	10214	9743	9271	8714
		25	14529	14286	14029	13600	13286	12786	12243	11571	10929
		30	17329	17143	16814	16314	15857	15300	14529	13929	13071

DIMENSION DIAGRAM

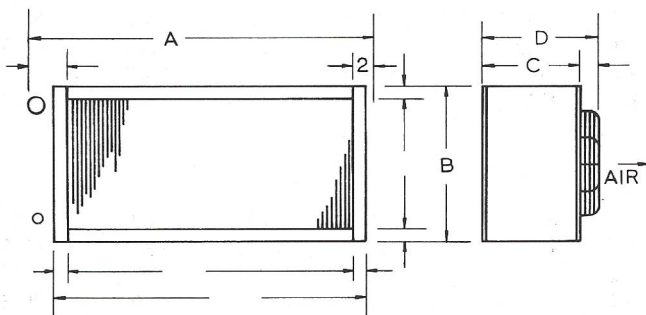

DIMENSIONS

(Inches)

MODEL NO.	A	B	C	D	CONN. IN—OD	CONN. OUT—OD
RAC - ¾	18"	18¼"	11⅝"	14"	⅝"	½"
RAC - 1	22"	20¼"	11⅝"	14"	⅝"	½"
RAC - 1½	24"	24¼"	11⅝"	14"	⅝"	½"
RAC - 2	26"	26¼"	11⅝"	14"	⅝"	½"
RAC - 3	32"	32¼"	11⅝"	14"	¾"	⅝"
RAC - 5	58"	26¼"	16⅞"	21"	1⅞"	⅞"
RAC - 7½	58"	30¼"	16⅞"	21"	1⅞"	⅞"
RAC - 10	72"	30¼"	16⅞"	21"	1⅞"	⅞"

COLD WEATHER CONTROL

In areas where the outside temperature drops to a point where there is insufficient pressure-drop across the TX valve to properly operate the valve, some type of control for maintaining adequate head-pressure in remote air-cooled condensers becomes necessary. There are several methods of control available, the selection of which should be governed by the lowest outside air temperature to be encountered where the air-cooled condenser is located.

The most common method, applicable only for single-circuit condensers, involves simple installation of pressure controls connected to the fan or fans, which can be set to cut out the fan or fans, at one time or in sequence, when the head pressure drops below the control setting. This method, in general, will maintain satisfactory head pressures where the outside air tem-

perature does not go below 40°F. Automatically controlled face dampers also can be utilized under the same general conditions, but their cost runs very high in proportion to the slightly additional control factor gained.

Other methods involve special circuits using high-side liquid pressure regulating valves, some of which circuits are patented.

Russell Coil Company does not sell valves of this type, nor do we suggest any particular type of cold weather control involving their use. For these reasons, we recommend you to your Refrigeration Parts Wholesaler who, in addition to stocking all types of controls for governing air cooled condenser head pressures, is qualified to advise you on various systems best suited to your specific application.

DIMENSIONAL DATA

BELT-DRIVEN HORIZONTAL DISCHARGE

MODEL	A	C	D	H	J	K	L	M	W
5 BDHD	21	3	24	47¼	39¼	42½	—	43	43½
7½ BDHD	24	3	27	51¼	43¼	44½	—	46	45½
10 BDHD	25	3	28	53¼	45¼	54½	—	47	55½
16 BDHD	24	4	28	71¼	63¼	76½	38¼	46	78½
20 BDHD	26	4	30	71¼	63¼	76½	38¼	48	78½
25 BDHD	24	6	30	83¼	75¼	95½	47¾	46	97½
30 BDHD	26	6	32	83¼	75¼	95½	47¾	48	97½
35 BDHD	26	6	32	83¼	75¼	109½	54¾	48	111½

SINGLE

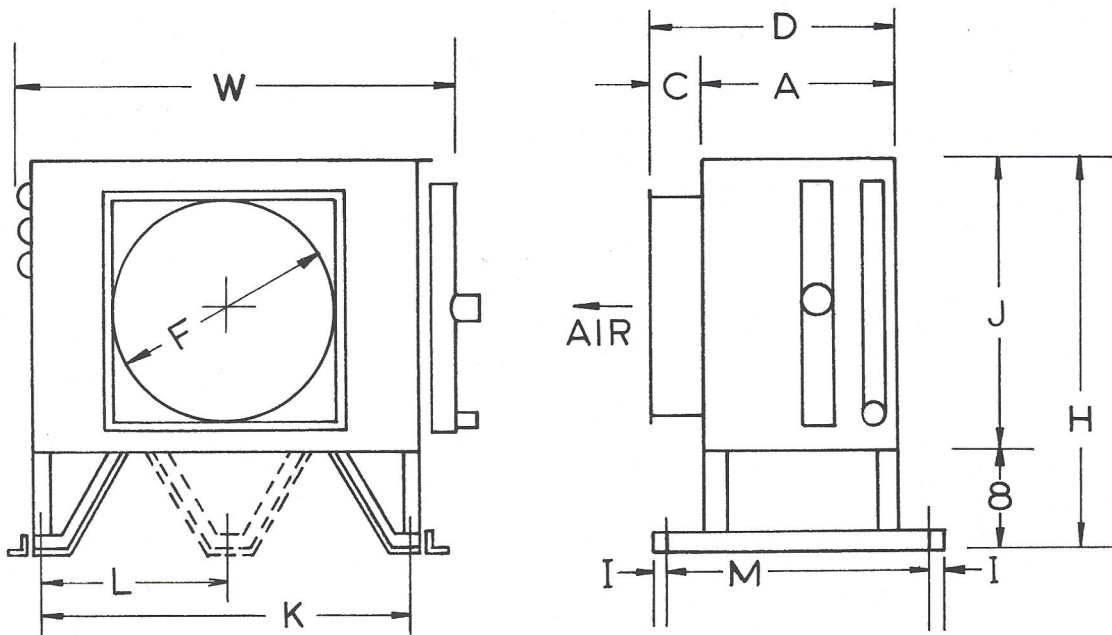

TWIN

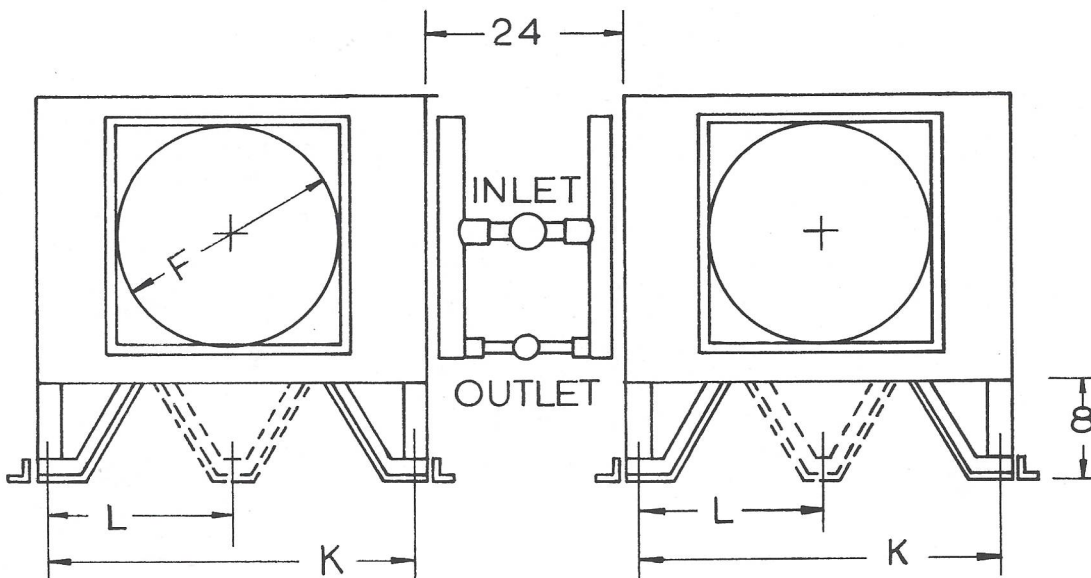

DIMENSIONAL DATA

BELT-DRIVEN VERTICAL DISCHARGE

MODEL	A	C	D	F	H	K	L	M	N	W
5 BDVD	21	3	39¼	30	48	39½	—	41	20½	43½
7½ BDVD	24	3	43¼	36	51	41½	—	45	22½	45¾
10 BDVD	25	3	45¼	36	52	51½	—	47	23½	55%
16 BDVD	24	4	63¼	48	52	73½	36¾	65	32½	78½
20 BDVD	26	4	63¼	48	54	73½	36¾	65	32½	78½
25 BDVD	24	6	75¼	60	54	92½	46¼	77	38½	97½
30 BDVD	26	6	75¼	60	56	92½	46¼	77	38½	97%
35 BDVD	26	6	75¼	60	56	106½	53¼	77	38½	111%

SINGLE

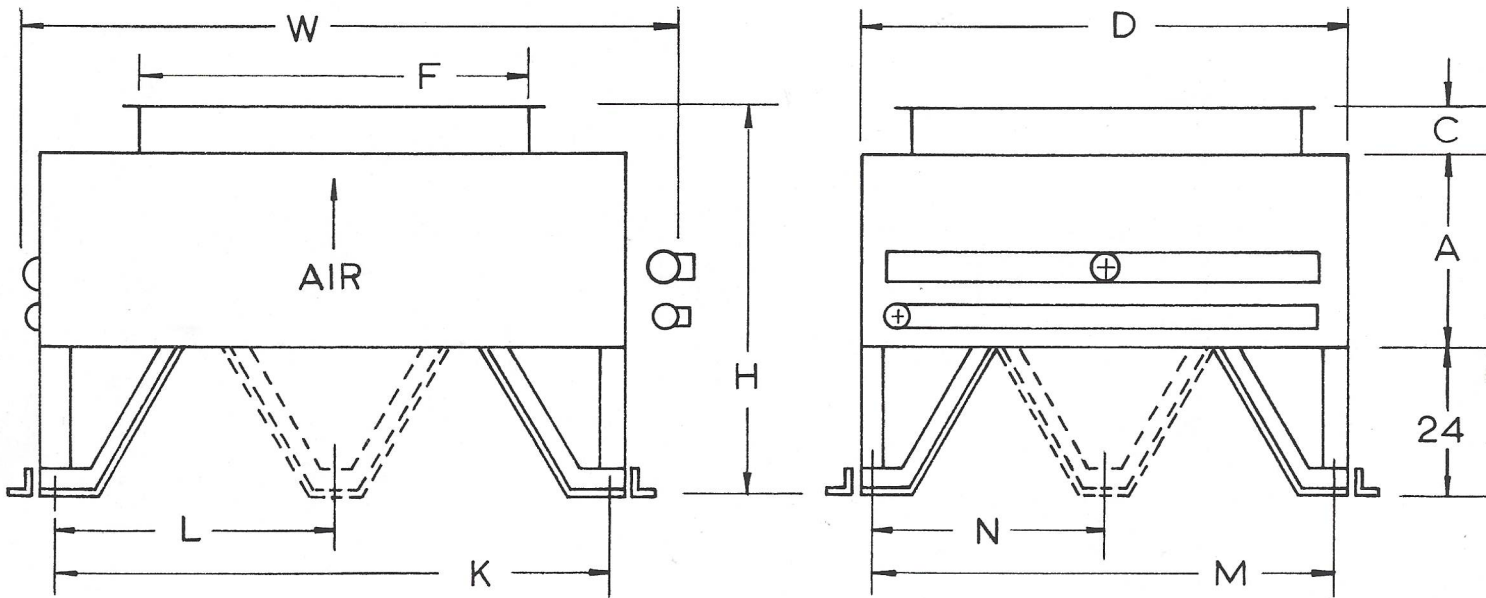

TWIN

