

RUSSELL

COIL COMPANY

RUSSELL
CORNER
COOLERS

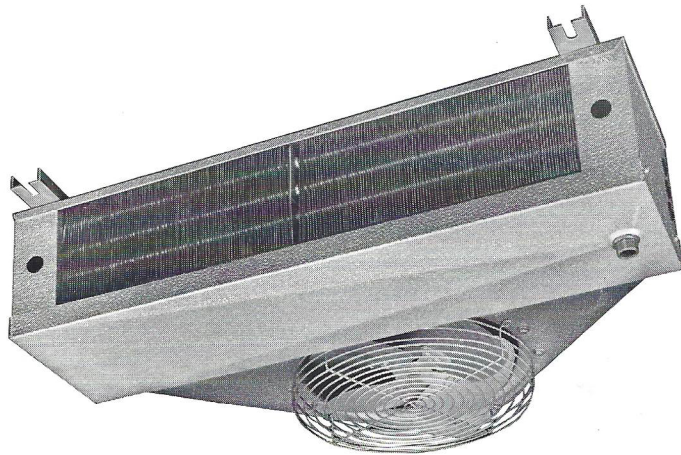

For beverage boxes, reach-ins and other installations where limited space requires a ceiling corner mounted coil of minimum height.

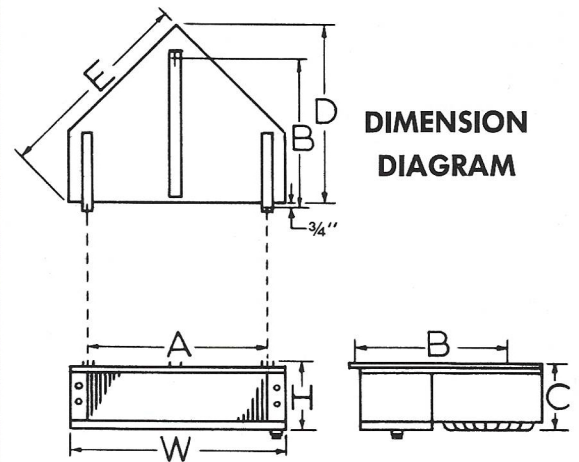

SPECIFICATIONS

MODEL	BTU/HR. RATING F-12		TOTAL SURFACE FT. ²	TUBE O.D.	FAN AND MOTOR			
	10°T.D.	15°T.D.			FAN DIA.	MOTOR H.P.	RPM	CFM
C-12	1200	1800	38.8	1/2"	8"	1/80	1500	210
C-15	1500	2250	51.8	1/2"	8"	1/80	1500	290
C-25	2500	3750	68.3	1/2"	10"	1/80	1500	450
C-35	3500	5250	96.3	5/8"	10"	1/30	1500	525
C-45	4500	6750	107.6	5/8"	12"	1/30	1500	600
C-65	6500	9750	148.0	5/8"	12"	1/30	1500	810
C-85	8500	12750	242.0	5/8"	16"	1/12	1050	1300
C-120	12000	18000	290.6	5/8"	16"	1/12	1050	1500

DIMENSIONS

MODEL	A	B	C	D	E	H	W
C-12	21"	17"	6"	19-3/4"	22-5/8"	6"	24-1/2"
C-15	21"	17"	6"	19-3/4"	22-5/8"	6"	24-1/2"
C-25	21"	17"	8"	20-3/4"	23-3/8"	7-1/2"	24-1/2"
C-35	29"	22-1/4"	8-1/4"	25-1/2"	29-5/8"	8"	33"
C-45	29"	22-1/4"	8-3/4"	25-1/2"	29-5/8"	8"	33"
C-65	29"	22-1/4"	10"	25-1/2"	29-5/8"	9-1/4"	33"
C-85	39"	27-3/4"	10"	31"	37-7/8"	9-1/4"	44"
C-120	39"	27-3/4"	12"	31"	37-7/8"	11-1/4"	44"

CONNECTION SIZES

Model	Liquid Conn.	Suct. Conn.	Drain Outlet
C-12	1/2" ODS	1/2" ODS	1/2" FP
C-15	1/2" ODS	1/2" ODS	1/2" FP
C-25	1/2" ODS	1/2" ODS	1/2" FP
C-35	1/2" ODS	5/8" ODS	1/2" FP
C-45	1/2" ODS	5/8" ODS	1/2" FP
C-65	1/2" ODS	5/8" ODS	1/2" FP
C-85	1/2" ODS	5/8" ODS	1/2" FP
C-120	1/2" ODS	7/8" ODS	1/2" FP