



R-Series Next-Gen MiniCon

1/2 TO 6 HP MULTI-REFRIGERANT AIR COOLED CONDENSING UNITS



R-SERIES

The Next Generation of MiniCons are Here!

Russell's Next-Gen MiniCon R-Series ½ through 6 HP condensing units are engineered with an exciting new design that provides increased efficiency, more standard features, easier serviceability, and more catalogued options.

Next-Gen MiniCons are ideally suited for use in a variety of commercial applications such as cafeterias, convenience stores, restaurants and fast food outlets while providing the versatility to excel in a full array of other applications. These new R-Series units provide a winning combination of high quality, increased flexibility and greatly improved efficiency for even lower long-term operating costs.

The small profile product line is designed to utilize R404A or other low GWP refrigerants R407A, R407C and R448/R449A. Units are available with low-cost hermetic or efficient and quiet scroll compressors. The standard Next-Gen R-Series is rated for operation in ambient air temperatures up to 110°F.

Integral Subcooling Circuit

All Next-Gen MiniCon units feature an integral subcooling circuit that allows saturated liquid to flow from the receiver to the condenser where the refrigerant is subcooled by ambient air. This provides an average of 3 to 5°F of subcooling for higher efficiency while assuring optimal expansion device operation.

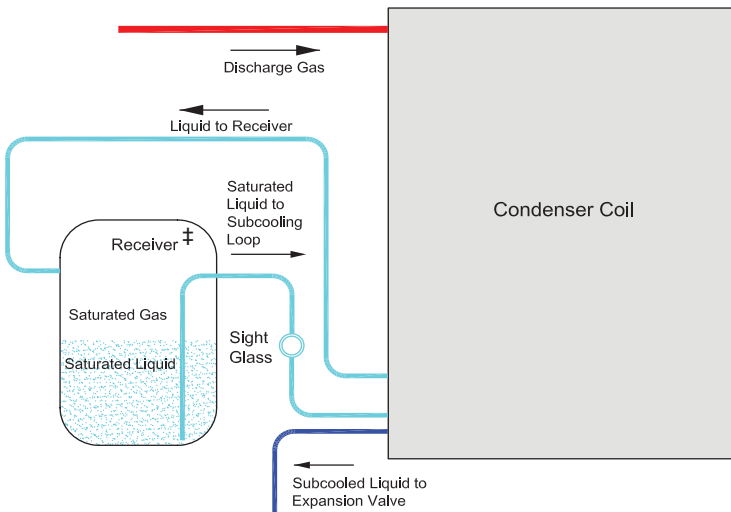

‡ Sierra models include a receiver section within the condenser and do not have a separate receiver tank.

Table of Contents

Page(s)

Features and Options Chart	4
Model Nomenclature	4
Capacity Data (BTUH) - Extended Medium Temperature - Hermetic R404A	5
Capacity Data (BTUH) - Extended Medium Temperature - Hermetic R407C	6
Capacity Data (BTUH) - Extended Medium Temperature - Hermetic R448A/R449A	7
Capacity Data (BTUH) - Extended Medium Temperature - Scroll R404A	8
Capacity Data (BTUH) - Extended Medium Temperature - Scroll R407A	9
Capacity Data (BTUH) - Extended Medium Temperature - Scroll R407C	10
Capacity Data (BTUH) - Extended Medium Temperature - Scroll R448A/R449A	11
Capacity Data (BTUH) - Low Temperature - Hermetic R404A	12
Capacity Data (BTUH) - Low Temperature - Scroll R404A	13
Capacity Data (BTUH) - Low Temperature - Scroll R407A	14
Capacity Data (BTUH) - Low Temperature - Scroll R407C	15
Capacity Data (BTUH) - Low Temperature - Scroll R448A/R449A	16
Electrical Data - Hermetic	17
Electrical Data - Scroll	18-19
Specifications - All Models	20-21
Physical Dimensions and Drawings - All Models	22-23

NEXT-GEN MINICON CONDENSING UNITS

Standard Features

- Low-cost Hermetic or quiet and efficient Scroll compressor
 - All-weather - Galvanized steel painted housing
 - Generously sized high efficiency condenser, enhanced copper tubes/aluminum fins
 - Integral Liquid Subcooling Circuit provides subcooled liquid to the expansion device
 - Base mounted shut-off valves placed external to cabinet for easy access
 - Liquid line kit with filter/drier and sight glass with moisture indicator
 - Suction line piping
 - Larger electrical panel with hinged/removable door
 - Color coded point-to-point wiring
 - Crankcase heater
 - Refrigerant receiver with isolation valve and pressure relief plug (not Sierra)
 - PSC condenser fan motor(s) with EC motor option
 - Encapsulated high pressure (auto reset) and low pressure (auto reset) controls (adjustable low pressure control is standard on low temperature models)
 - Electronic defrost timer with defrost contactor/relay on low temperature models (2 evaps. maximum)
 - Electronic air defrost timer (Medium temperature models only)
 - UL and cUL listed for indoor or outdoor use
- RFH/RFO** models include flooded head pressure control as a standard feature
- RVH/RVO** models feature the **Sierra™** refrigeration system and no refrigerant receiver

Sierra™ Refrigeration Condensing Units

The unique design provides built-in refrigerant storage capacity in the condenser section of the condensing unit. They require up to 20% less refrigerant to operate while maintaining continuous peak performance.

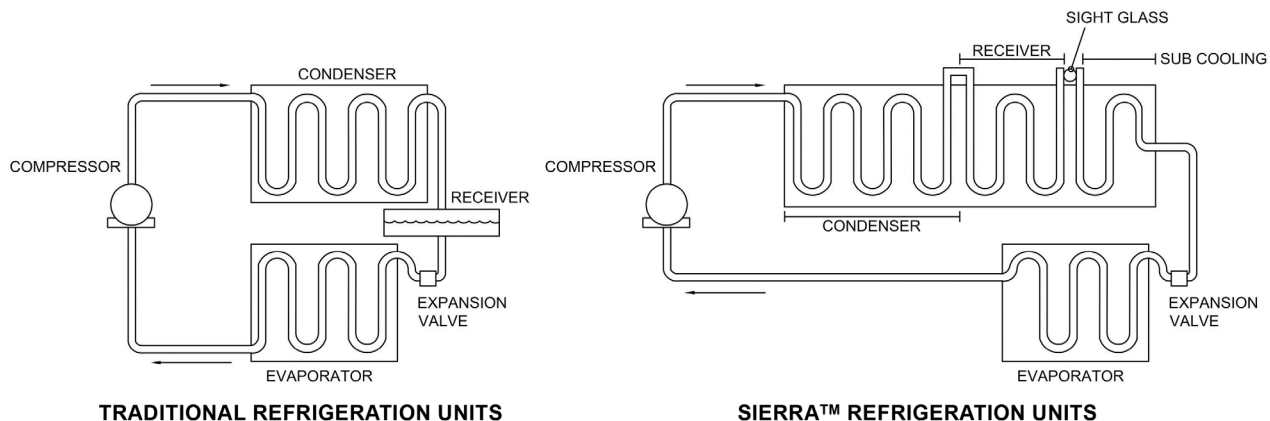

Options

- Suction accumulator
- Oil separator (may not be available with mounted accumulator)
- Thru-the-door fused disconnect for cabinet sizes FM2 through FM4
- External fused or non-fused disconnect - loose or mounted
- Heated and insulated receiver
- Oversized receiver
- Adjustable high/low pressure control
- Hose option for adjustable pressure control
- EC condenser motor
- Pump down toggle switch
- Liquid line solenoid (loose or mounted)
- Phase loss monitor
- Hail / Snow Guard - loose or mounted
- Paragon mechanical timer in lieu of electronic timer
- Timer shipped loose in enclosure
- CPC timer
- 316 Stainless steel housing
- 50 Hz timer and/or defrost kit

R-SERIES

Features and Options

	DESCRIPTION	FLOODED MODELS		NON-FLOODED MODELS		SIERRA MODELS	
		RFH	RFO	RBH	RBO	RVH	RVO
CABINET	All weather housing - Pre-painted grey	STANDARD		STANDARD		STANDARD	
	316 Stainless Steel	OPTIONAL		OPTIONAL		OPTIONAL	
	Hail / Snow Guards - Loose or Mounted	OPTIONAL		OPTIONAL		OPTIONAL	
	Large Control panel for power and control circuits	STANDARD		STANDARD		STANDARD	
	Hinged / removable control panel door	STANDARD		STANDARD		STANDARD	
COMPRESSOR	Hermetic	STD	N/A	STD	N/A	STD	N/A
	Scroll	N/A	STD	N/A	STD	N/A	STD
ELECTRICAL	Crankcase heater	STANDARD		STANDARD		STANDARD	
	Compressor contactor (1Ø or 3Ø), start kit (1Ø)	STANDARD		STANDARD		STANDARD	
	Control transformer (460V to 230V) as required	STANDARD		STANDARD		STANDARD	
	**Encapsulated high and low pressure controls	STANDARD		STANDARD		STANDARD	
	Color coded wiring for maximum serviceability	STANDARD		STANDARD		STANDARD	
HIGH EFFICIENCY CONDENSER	Enhanced Copper tubes, Aluminum fins	STANDARD		STANDARD		STANDARD	
	High ambient coil	STANDARD		STANDARD		STANDARD	
	Integral Subcooling Circuit	STANDARD		STANDARD		STANDARD	
	PSC Fan motor(s) - overload protection	STANDARD		STANDARD		STANDARD	
	EC Fan motor(s) - overload protection	OPTIONAL		OPTIONAL		OPTIONAL	
	Copper, polyester coated fins or Electro Fin coated coil	OPTIONAL		OPTIONAL		OPTIONAL	
	Integral receiver section	N/A		N/A		STANDARD	
PIPING COMPONENTS	Base mounted liquid and suction shut-off valves	STANDARD		STANDARD		STANDARD	
	Suction line (piping only)	STANDARD		STANDARD		STANDARD	
	Suction kit (piping and suction filter)	OPTIONAL		OPTIONAL		STANDARD	
	Suction line accumulator	OPTIONAL		OPTIONAL		STANDARD	
	*Liquid line kit	STANDARD		STANDARD		STANDARD	
RECEIVER⁺	Receiver Isolation valve	STANDARD		STANDARD		STANDARD ⁺	
	Pressure relief plug	STANDARD		STANDARD		N/A	
	Oversized receiver	OPTIONAL		OPTIONAL		N/A	
LOW AMBIENT CONTROLS	Flooded head pressure control	STANDARD		N/A		N/A	
	Fan cycle control (2 Fan models only)	N/A		STANDARD		STANDARD	
DEFROST PROVISIONS	^Electronic Air defrost time clock for medium temps.	STANDARD		STANDARD		STANDARD	
	Mechanical defrost timer	OPTIONAL		OPTIONAL		OPTIONAL	
	50 Hz defrost timers with or without contactors	OPTIONAL		OPTIONAL		OPTIONAL	
	Surveillant family of electronic system controllers	OPTIONAL		OPTIONAL		OPTIONAL	
	Electric defrost	(1)	(1)	(1)	(1)	(1)	(1)
TESTING	UL and cUL listed	STANDARD		STANDARD		STANDARD	
	Hydrogen leak and dielectric tested before shipping	STANDARD		STANDARD		STANDARD	
	Dry Nitrogen shipping charge (25 to 35 PSI)	STANDARD		STANDARD		STANDARD	

MODEL NUMBER NOMENCLATURE

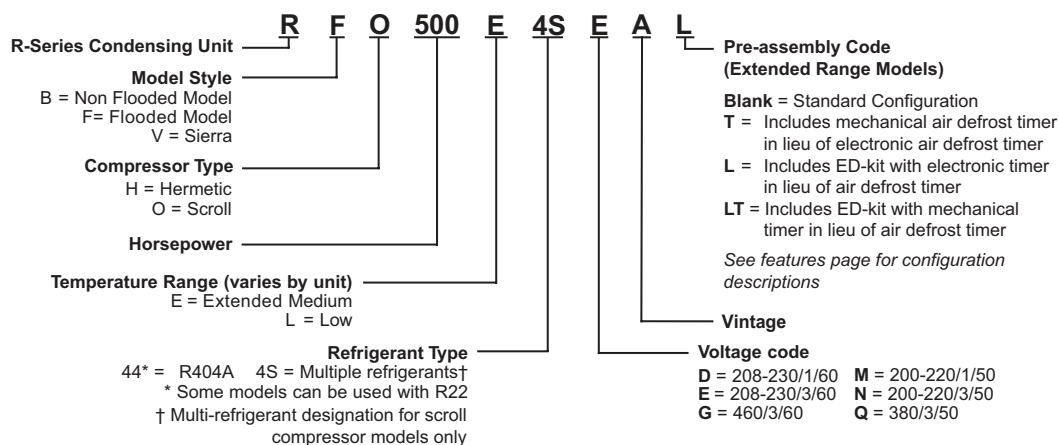

STD = Standard Feature
 N/A = Not Available

*Liquid line kit includes: Piping, filter drier, sight glass/moisture indicator.

**Adjustable low pressure control on low temp. models in lieu of fixed control.

+ Sierra units do not include a receiver tank.

^ Standard on extended medium temp. models only.

(1) Electric defrost kit is included on low temp. models and optional for medium temp. models - see pages 17-19.

(2) Sierra models are critical charge units - see pages 3 and 20.

See specification pages 20-21 for compressor horsepower.

NEXT-GEN MINICON CONDENSING UNITS

Capacity Data (BTUH) - Extended Medium Temperature R404A Hermetic - 60 Hz[‡]

SUCTION TEMPERATURE

MODEL	30°F	25°F	20°F	10°F	5°F	0°F	-5°F	-10°F	-20°F	-25°F
-------	------	------	------	------	-----	-----	------	-------	-------	-------

90°F Ambient

R*H055E44**	6,660	6,020	5,420	4,350	3,850	3,390	2,940	2,520	1,700	1,310
R*H080E44**	8,270	7,410	6,610	5,180	4,540	3,960	3,420	2,930	2,070	1,690
R*H090E44**	9,930	9,080	8,260	6,690	5,950	5,250	4,590	3,980	2,870	2,370
R*H100E44**	10,590	9,570	8,610	6,820	6,010	5,250	4,560	3,920	2,830	2,360
R*H125E44**	14,260	13,080	11,910	9,690	8,640	7,640	6,690	5,820	4,300	3,680
R*H150E44**	16,270	14,720	13,190	10,260	8,870	7,530	6,270	5,110	3,130	2,340
R*H200E44**	18,960	16,960	15,070	11,650	10,100	8,640	7,270	5,970	3,580	2,470
R*H250E44**	22,170	20,230	18,300	14,510	12,700	10,980	9,350	7,840	5,230	4,150
R*H300E44**	27,060	24,730	22,400	17,760	15,500	13,300	11,240	9,330	6,120	4,890
R*H325E44**	35,720	31,530	27,770	21,320	18,560	16,050	13,740	11,600	7,610	5,670

95°F Ambient

R*H055E44**	6,350	5,740	5,170	4,130	3,660	3,210	2,780	2,370	1,580	1,200
R*H080E44**	7,860	7,040	6,270	4,890	4,280	3,720	3,200	2,730	1,900	1,540
R*H090E44**	9,470	8,650	7,860	6,360	5,650	4,970	4,340	3,740	2,670	2,200
R*H100E44**	10,090	9,110	8,190	6,480	5,700	4,970	4,310	3,690	2,640	2,190
R*H125E44**	13,620	12,470	11,350	9,200	8,190	7,230	6,320	5,470	4,020	3,420
R*H150E44**	15,280	13,810	12,340	9,530	8,200	6,920	5,720	4,610	2,740	1,990
R*H200E44**	17,870	15,950	14,140	10,850	9,360	7,970	6,650	5,410	3,130	2,070
R*H250E44**	20,940	19,070	17,230	13,620	11,890	10,240	8,690	7,250	4,760	3,740
R*H300E44**	25,490	23,260	21,020	16,560	14,400	12,310	10,340	8,530	5,520	4,370
R*H325E44**	33,580	29,590	25,970	19,800	17,170	14,770	12,570	10,530	6,720	4,870

100°F Ambient

R*H055E44**	6,030	5,450	4,900	3,910	3,460	3,030	2,620	2,220	1,460	1,090
R*H080E44**	7,460	6,670	5,930	4,610	4,020	3,490	2,990	2,540	1,740	1,400
R*H090E44**	9,010	8,220	7,460	6,020	5,340	4,700	4,090	3,510	2,480	2,030
R*H100E44**	9,580	8,650	7,770	6,130	5,380	4,690	4,050	3,460	2,450	2,020
R*H125E44**	12,960	11,860	10,780	8,710	7,740	6,810	5,930	5,120	3,730	3,150
R*H150E44**	14,320	12,910	11,490	8,810	7,540	6,320	5,170	4,120	2,350	1,640
R*H200E44**	16,800	14,950	13,210	10,050	8,630	7,300	6,040	4,860	2,700	1,690
R*H250E44**	19,700	17,920	16,160	12,730	11,080	9,510	8,040	6,670	4,300	3,320
R*H300E44**	24,000	21,820	19,650	15,390	13,320	11,330	9,470	7,760	4,940	3,890
R*H325E44**	31,510	27,670	24,210	18,310	15,790	13,510	11,410	9,460	5,840	4,080

110°F Ambient

R*H055E44**	5,380	4,860	4,360	3,460	3,050	2,660	2,280	1,920	1,220	880
R*H080E44**	6,660	5,950	5,270	4,070	3,530	3,040	2,590	2,180	1,470	1,150
R*H090E44**	8,060	7,350	6,660	5,360	4,740	4,150	3,590	3,070	2,130	1,710
R*H100E44**	8,550	7,700	6,900	5,420	4,730	4,100	3,520	2,980	2,060	1,660
R*H125E44**	11,630	10,610	9,610	7,710	6,810	5,960	5,160	4,420	3,140	2,620
R*H150E44**	12,380	11,090	9,820	7,380	6,230	5,120	4,090	3,140	1,570	940
R*H200E44**	14,610	12,940	11,360	8,490	7,200	6,000	4,870	3,810	1,900	1,030
R*H250E44**	17,200	15,600	14,030	10,940	9,460	8,050	6,730	5,500	3,390	2,520
R*H300E44**	20,890	18,940	16,990	13,110	11,240	9,460	7,800	6,290	3,870	3,000
R*H325E44**	27,470	23,920	20,780	15,410	13,130	11,050	9,150	7,380	4,110	2,510

* Each asterisk represents a variable character based upon model, voltage, and vintage ordered. See page 4 for nomenclature.

‡ Multiply capacity by .83 when used with 50 Hz power.

R-SERIES

Capacity Data (BTUH) - Extended Medium Temperature R407C Hermetic - 60 Hz[‡]

SUCTION TEMPERATURE

MODEL	30°F	25°F	20°F	10°F	15°F	5°F	0°F
-------	------	------	------	------	------	-----	-----

90°F Ambient

R*H055E4S**	6,650	5,870	5,150	4,500	3,920	3,390	2,950
R*H080E4S**	7,820	6,850	5,980	5,210	4,500	3,870	3,290
R*H090E4S**	9,930	8,830	7,810	6,870	6,000	5,200	4,470
R*H100E4S**	10,150	8,990	7,950	6,980	6,090	5,280	4,520
R*H125E4S**	13,850	12,350	10,970	9,710	8,550	7,470	6,450

95°F Ambient

R*H055E4S**	6,400	5,650	4,950	4,320	3,750	3,250	–
R*H080E4S**	7,550	6,620	5,780	5,020	4,340	3,720	–
R*H090E4S**	9,540	8,470	7,490	6,590	5,760	4,990	–
R*H100E4S**	9,780	8,660	7,650	6,710	5,860	5,070	–
R*H125E4S**	13,350	11,890	10,560	9,340	8,210	7,160	–

100°F Ambient

R*H055E4S**	6,150	5,430	4,750	4,140	3,590	–	–
R*H080E4S**	7,290	6,390	5,570	4,840	4,180	–	–
R*H090E4S**	9,170	8,130	7,190	6,330	5,510	–	–
R*H100E4S**	9,410	8,330	7,360	6,460	5,620	–	–
R*H125E4S**	12,860	11,460	10,170	8,990	7,890	–	–

110°F Ambient

R*H055E4S**	5,690	5,010	4,370	3,800	3,270	–	–
R*H080E4S**	6,770	5,940	5,180	4,490	3,870	–	–
R*H090E4S**	8,420	7,470	6,600	5,790	5,050	–	–
R*H100E4S**	8,690	7,680	6,770	5,930	5,160	–	–
R*H125E4S**	11,300	10,420	9,410	8,290	7,260	–	–

* Each asterisk represents a variable character based upon model, voltage, and vintage ordered. See page 4 for nomenclature.

‡ Multiply capacity by .83 when used with 50 Hz power.

Hermetic compressors are not available for use with R407A.



Easy access / removable control panel door

Color-coded and numbered point-to-point wiring for easy maintenance



Quick access to shut-off valves from cabinet exterior



Replaceable core liquid and suction filters available as an option for 4 to 6 HP models

NEXT-GEN MINICON CONDENSING UNITS

Capacity Data (BTUH) - Extended Medium Temperature R448A/449A Hermetic - 60 Hz[‡]

SUCTION TEMPERATURE

MODEL	30°F	25°F	20°F	10°F	15°F	5°F	0°F
-------	------	------	------	------	------	-----	-----

90°F Ambient

R*H055E4S**	6,890	6,060	5,310	4,640	4,030	3,480	3,000
R*H080E4S**	8,550	7,460	6,480	5,590	4,800	4,100	3,490
R*H090E4S**	9,300	8,260	7,320	6,470	5,690	4,990	4,370
R*H100E4S**	9,970	8,940	7,990	7,080	6,240	5,450	4,720
R*H125E4S**	13,460	12,240	11,060	9,930	8,860	7,840	6,870

95°F Ambient

R*H055E4S**	6,600	5,800	5,080	4,420	3,840	3,320	2,850
R*H080E4S**	8,160	7,120	6,160	5,300	4,540	3,870	3,290
R*H090E4S**	8,930	7,920	7,020	6,200	5,460	4,790	4,180
R*H100E4S**	9,600	8,600	7,680	6,810	5,990	5,230	4,520
R*H125E4S**	12,990	11,790	10,650	9,550	8,500	7,510	6,570

100°F Ambient

R*H055E4S**	6,300	5,540	4,840	4,220	3,650	3,150	2,700
R*H080E4S**	7,800	6,780	5,860	5,030	4,300	3,650	3,100
R*H090E4S**	8,570	7,600	6,730	5,950	5,230	4,580	4,010
R*H100E4S**	9,230	8,280	7,380	6,540	5,740	5,000	4,310
R*H125E4S**	12,520	11,360	10,250	9,180	8,150	7,180	6,260

110°F Ambient

R*H055E4S**	5,740	5,040	4,390	3,810	3,290	—	—
R*H080E4S**	7,100	6,170	5,310	4,550	3,860	—	—
R*H090E4S**	7,880	6,980	6,170	5,450	4,790	—	—
R*H100E4S**	8,520	7,620	6,790	5,990	5,250	—	—
R*H125E4S**	11,620	10,510	9,450	8,430	7,460	—	—

* Each asterisk represents a variable character based upon model, voltage, and vintage ordered. See page 4 for nomenclature.

‡ Multiply capacity by .83 when used with 50 Hz power.



Next-Gen MiniCon Condensing Units provide a complete refrigeration solution for small to medium walk-ins when combined with Russell's low profile unit coolers.

R-SERIES

Capacity Data (BTUH) - Extended Medium Temperature R404A Scroll - 60 Hz[‡]

SUCTION TEMPERATURE

MODEL	45°F	40°F	35°F	25°F	20°F	10°F	0°F	-10°F	-20°F	-25°F
-------	------	------	------	------	------	------	-----	-------	-------	-------

90°F Ambient

R*O130E4S**	15,160	14,840	13,430	11,130	10,110	8,280	6,690	5,330	4,210	3,720
R*O150E4S**	20,650	18,880	17,210	14,270	12,910	10,480	8,410	6,670	5,230	4,620
R*O180E4S**	22,860	20,880	19,050	15,990	14,490	11,790	9,500	7,560	5,950	5,250
R*O200E4S**	29,910	27,310	24,810	20,050	18,100	14,600	11,660	9,230	7,240	6,380
R*O250E4S**	33,590	30,670	27,960	21,960	19,880	16,150	12,930	10,250	8,050	7,100
R*O300E4S**	43,440	39,690	36,150	30,480	27,480	22,160	17,700	13,980	10,940	9,640
R*O350E4S**	48,350	44,180	40,330	33,600	30,320	24,490	19,590	15,520	12,150	10,710
R*O400E4S**	54,010	49,420	45,140	37,710	34,070	27,600	22,120	17,560	13,790	12,170
R*O450E4S**	60,720	55,510	50,610	42,490	38,310	30,890	24,660	19,460	15,220	13,410
R*O500E4S**	68,320	62,580	56,840	46,660	42,420	34,800	28,260	22,680	17,950	15,880
R*O600E4S**	80,860	73,560	67,300	55,630	50,700	41,850	34,240	27,730	22,150	19,660

95°F Ambient

R*O130E4S**	14,500	14,200	12,850	10,640	9,670	7,920	6,400	5,110	4,040	3,570
R*O150E4S**	19,800	18,100	16,500	13,690	12,380	10,050	8,060	6,400	5,030	4,440
R*O180E4S**	21,900	20,000	18,250	15,320	13,880	11,290	9,100	7,250	5,710	5,050
R*O200E4S**	28,700	26,200	23,800	19,230	17,350	14,010	11,190	8,860	6,950	6,140
R*O250E4S**	32,200	29,400	26,800	21,060	19,060	15,480	12,400	9,830	7,730	6,830
R*O300E4S**	41,700	38,100	34,700	29,260	26,370	21,260	16,970	13,410	10,500	9,270
R*O350E4S**	46,400	42,400	38,700	32,240	29,080	23,490	18,790	14,890	11,670	10,300
R*O400E4S**	51,800	47,400	43,300	36,160	32,670	26,450	21,210	16,840	13,240	11,700
R*O450E4S**	58,300	53,300	48,600	40,790	36,760	29,630	23,650	18,670	14,620	12,890
R*O500E4S**	65,500	60,000	54,500	44,710	40,630	33,310	27,030	21,700	17,190	15,230
R*O600E4S**	77,500	70,500	64,500	53,280	48,530	40,030	32,730	26,520	21,230	18,880

100°F Ambient

R*O130E4S**	13,830	13,540	12,260	10,150	9,220	7,550	6,110	4,880	3,860	3,420
R*O150E4S**	18,930	17,310	15,780	13,080	11,830	9,600	7,710	6,120	4,810	4,260
R*O180E4S**	20,910	19,100	17,430	14,640	13,260	10,780	8,690	6,930	5,470	4,840
R*O200E4S**	27,440	25,050	22,760	18,400	16,600	13,400	10,700	8,480	6,660	5,890
R*O250E4S**	30,800	28,120	25,630	20,130	18,220	14,790	11,860	9,410	7,400	6,550
R*O300E4S**	39,920	36,480	33,220	28,000	25,240	20,340	16,230	12,830	10,060	8,890
R*O350E4S**	44,420	40,590	37,050	30,850	27,830	22,470	17,970	14,240	11,180	9,870
R*O400E4S**	49,560	45,350	41,420	34,580	31,240	25,290	20,270	16,110	12,680	11,210
R*O450E4S**	55,830	51,040	46,540	39,050	35,190	28,350	22,630	17,870	14,010	12,370
R*O500E4S**	62,640	57,380	52,120	42,740	38,820	31,800	25,790	20,700	16,410	14,540
R*O600E4S**	74,070	67,380	61,650	50,900	46,350	38,200	31,220	25,300	20,290	18,070

110°F Ambient

R*O130E4S**	-	-	-	9,120	8,290	6,790	5,500	4,390	3,480	3,090
R*O150E4S**	-	14,980	13,660	11,840	10,700	8,670	6,960	5,540	4,370	3,870
R*O180E4S**	-	16,470	15,030	13,220	11,970	9,730	7,840	6,260	4,950	4,390
R*O200E4S**	-	21,730	19,740	16,680	15,040	12,140	9,700	7,680	6,050	5,350
R*O250E4S**	-	24,350	22,200	18,220	16,480	13,380	10,720	8,510	6,710	5,950
R*O300E4S**	-	31,720	28,890	25,420	22,890	18,430	14,700	11,630	9,140	8,090
R*O350E4S**	-	35,260	32,190	27,990	25,220	20,340	16,260	12,890	10,140	8,970
R*O400E4S**	-	39,310	35,910	31,330	28,280	22,870	18,330	14,560	11,500	10,180
R*O450E4S**	-	44,420	40,500	35,450	31,930	25,700	20,490	16,200	12,720	11,250
R*O500E4S**	-	49,800	45,230	38,740	35,140	28,710	23,240	18,630	14,770	13,100
R*O600E4S**	-	58,380	53,410	46,090	41,930	34,480	28,140	22,810	18,340	16,390

* Each asterisk represents a variable character based upon model, voltage, and vintage ordered. See page 4 for nomenclature.

‡ Multiply capacity by .83 when used with 50 Hz power.

NEXT-GEN MINICON CONDENSING UNITS

Capacity Data (BTUH) - Extended Medium Temperature R407A Scroll - 60 Hz[‡]

SUCTION TEMPERATURE

MODEL	45°F	40°F	35°F	30°F	25°F	20°F	10°F	0°F	-5°F	-10°F
-------	------	------	------	------	------	------	------	-----	------	-------

90°F Ambient

R*O130E4S**	16,150	14,530	13,120	11,650	10,590	9,610	7,870	6,380	5,700	5,070
R*O150E4S**	19,970	17,990	16,220	14,570	13,210	11,960	9,740	7,850	7,000	6,210
R*O180E4S**	22,440	20,250	18,270	16,420	14,900	13,510	11,040	8,920	7,960	7,070
R*O200E4S**	27,410	24,700	22,310	20,240	18,320	16,560	13,470	10,850	9,680	8,580
R*O250E4S**	30,560	27,540	24,830	22,610	20,490	18,540	15,100	12,180	10,870	9,640
R*O300E4S**	41,460	37,400	33,750	30,570	27,640	24,960	20,250	16,290	14,520	12,860
R*O350E4S**	46,680	42,100	37,930	33,770	30,560	27,620	22,440	18,060	16,110	14,270
R*O400E4S**	51,300	46,190	41,700	37,530	33,990	30,740	25,030	20,160	17,990	15,950
R*O450E4S**	59,050	53,220	48,010	43,300	39,160	35,350	28,690	23,070	20,560	18,220
R*O500E4S**	62,790	57,570	52,670	48,900	44,200	39,700	31,220	25,620	22,960	20,430
R*O600E4S**	71,990	65,630	59,580	51,310	47,590	43,900	36,680	29,890	26,730	23,770

95°F Ambient

R*O130E4S**	15,450	13,900	12,550	11,230	10,220	9,270	7,590	6,140	5,490	4,880
R*O150E4S**	19,150	17,250	15,550	14,070	12,750	11,540	9,390	7,560	6,740	5,970
R*O180E4S**	21,500	19,400	17,500	15,850	14,390	13,040	10,650	8,590	7,670	6,800
R*O200E4S**	26,300	23,700	21,400	19,560	17,700	15,990	13,000	10,460	9,330	8,260
R*O250E4S**	29,300	26,400	23,800	21,850	19,800	17,900	14,570	11,740	10,470	9,280
R*O300E4S**	39,800	35,900	32,400	29,550	26,710	24,110	19,540	15,700	13,990	12,380
R*O350E4S**	44,800	40,400	36,400	32,640	29,520	26,670	21,660	17,410	15,510	13,740
R*O400E4S**	49,200	44,300	40,000	36,260	32,840	29,680	24,150	19,430	17,330	15,360
R*O450E4S**	56,700	51,100	46,100	41,850	37,840	34,150	27,680	22,240	19,810	17,540
R*O500E4S**	60,200	55,200	50,500	47,200	42,600	38,200	30,360	24,900	22,300	19,830
R*O600E4S**	69,000	62,900	57,100	50,080	46,430	42,810	35,750	29,100	26,010	23,120

100°F Ambient

R*O130E4S**	14,740	13,260	11,970	10,820	9,850	8,930	7,300	5,910	5,280	4,680
R*O150E4S**	18,310	16,500	14,870	13,560	12,290	11,120	9,040	7,270	6,480	5,740
R*O180E4S**	20,530	18,530	16,710	15,280	13,860	12,560	10,250	8,270	7,370	6,530
R*O200E4S**	25,150	22,660	20,460	18,880	17,080	15,420	12,520	10,070	8,970	7,940
R*O250E4S**	28,020	25,250	22,760	21,080	19,100	17,260	14,040	11,300	10,080	8,920
R*O300E4S**	38,100	34,370	31,020	28,510	25,760	23,250	18,830	15,110	13,460	11,900
R*O350E4S**	42,890	38,680	34,850	31,490	28,470	25,720	20,870	16,750	14,920	13,200
R*O400E4S**	47,070	42,380	38,270	34,970	31,660	28,610	23,260	18,710	16,670	14,760
R*O450E4S**	54,300	48,940	44,150	40,390	36,500	32,940	26,670	21,400	19,050	16,860
R*O500E4S**	57,580	52,790	48,300	45,600	41,100	36,800	29,490	24,150	21,620	19,220
R*O600E4S**	65,950	60,120	54,580	48,840	45,270	41,720	34,810	28,310	25,280	22,450

110°F Ambient

R*O130E4S**	-	-	-	9,990	9,090	8,250	6,740	5,440	-	-
R*O150E4S**	-	-	12,870	12,540	11,360	10,270	8,340	6,700	-	-
R*O180E4S**	-	-	14,410	14,120	12,810	11,600	9,460	7,620	-	-
R*O200E4S**	-	-	17,750	17,490	15,810	14,270	11,570	9,280	-	-
R*O250E4S**	-	-	19,710	19,530	17,690	15,980	12,980	10,430	-	-
R*O300E4S**	-	-	26,980	26,420	23,850	21,510	17,400	13,930	-	-
R*O350E4S**	-	-	30,270	29,160	26,350	23,780	19,270	15,440	-	-
R*O400E4S**	-	-	33,180	32,370	29,290	26,460	21,470	17,250	-	-
R*O450E4S**	-	-	38,420	37,420	33,790	30,480	24,640	19,730	-	-
R*O500E4S**	-	-	44,190	43,900	39,500	35,300	27,700	22,640	-	-
R*O600E4S**	-	-	47,280	46,310	42,880	39,480	32,880	26,670	-	-

* Each asterisk represents a variable character based upon model, voltage, and vintage ordered. See page 4 for nomenclature.

‡ Multiply capacity by .83 when used with 50 Hz power.

20°F Superheat Maximum

R-SERIES

Capacity Data (BTUH) - Extended Medium Temperature R407C Scroll - 60 Hz[‡]

SUCTION TEMPERATURE

MODEL	45°F	40°F	35°F	30°F	25°F	20°F	10°F	0°F	-5°F	-10°F
-------	------	------	------	------	------	------	------	-----	------	-------

90°F Ambient

R*O130E4S**	15,350	13,950	12,700	11,150	10,120	9,130	7,260	5,520	4,690	3,890
R*O150E4S**	18,980	17,280	15,700	13,950	12,630	11,360	8,980	6,790	5,760	4,760
R*O180E4S**	21,330	19,450	17,680	15,720	14,240	12,840	10,180	7,720	6,550	5,420
R*O200E4S**	26,050	23,720	21,590	19,380	17,510	15,740	12,420	9,390	7,960	6,580
R*O250E4S**	29,050	26,450	24,030	21,650	19,590	17,620	13,930	10,540	8,940	7,390
R*O300E4S**	40,110	36,560	33,250	29,790	26,900	24,140	19,010	14,350	12,150	10,030
R*O350E4S**	44,680	40,610	36,840	32,550	29,520	26,660	21,360	16,460	14,090	11,720
R*O400E4S**	49,540	45,070	41,010	36,510	33,020	29,680	23,460	17,730	15,030	12,420
R*O450E4S**	55,630	50,660	46,060	41,100	37,110	33,300	26,230	19,790	16,760	13,840
R*O500E4S**	62,630	57,430	52,540	48,780	44,090	39,600	31,140	25,560	22,900	20,380
R*O600E4S**	71,810	65,460	59,430	51,180	47,470	43,790	36,590	29,820	26,660	23,710

95°F Ambient

R*O130E4S**	14,770	13,440	12,240	10,830	9,850	8,880	7,050	5,330	4,500	3,700
R*O150E4S**	18,300	16,680	15,170	13,560	12,280	11,060	8,730	6,560	5,530	4,530
R*O180E4S**	20,550	18,760	17,070	15,280	13,860	12,490	9,900	7,450	6,290	5,150
R*O200E4S**	25,140	22,920	20,880	18,860	17,050	15,320	12,080	9,080	7,650	6,260
R*O250E4S**	28,010	25,530	23,220	21,060	19,080	17,150	13,540	10,190	8,590	7,030
R*O300E4S**	38,720	35,340	32,180	29,000	26,190	23,510	18,480	13,870	11,680	9,550
R*O350E4S**	43,110	39,220	35,610	31,650	28,700	25,920	20,730	15,880	13,510	11,150
R*O400E4S**	47,790	43,540	39,660	35,520	32,150	28,900	22,800	17,130	14,440	11,830
R*O450E4S**	53,730	48,990	44,590	40,000	36,140	32,430	25,500	19,130	16,110	13,180
R*O500E4S**	60,050	55,060	50,370	47,080	42,490	38,110	30,280	24,840	22,240	19,780
R*O600E4S**	68,830	62,740	56,960	49,960	46,310	42,700	35,660	29,030	25,950	23,060

100°F Ambient

R*O130E4S**	14,080	12,820	11,680	10,520	9,570	8,630	6,830	5,130	4,300	3,490
R*O150E4S**	17,500	15,950	14,510	13,180	11,940	10,750	8,460	6,310	5,280	4,280
R*O180E4S**	19,630	17,920	16,300	14,850	13,470	12,140	9,590	7,180	6,010	4,860
R*O200E4S**	24,040	21,920	19,970	18,350	16,600	14,900	11,710	8,740	7,310	5,910
R*O250E4S**	26,790	24,420	22,210	20,490	18,560	16,680	13,140	9,810	8,210	6,640
R*O300E4S**	37,070	33,830	30,800	28,200	25,480	22,870	17,930	13,350	11,170	9,020
R*O350E4S**	41,270	37,550	34,090	30,740	27,880	25,170	20,090	15,270	12,900	10,520
R*O400E4S**	45,720	41,650	37,940	34,540	31,260	28,100	22,120	16,500	13,810	11,170
R*O450E4S**	51,450	46,920	42,700	38,910	35,160	31,560	24,740	18,410	15,390	12,450
R*O500E4S**	57,430	52,660	48,180	45,490	41,000	36,710	29,420	24,090	21,570	19,170
R*O600E4S**	65,790	59,970	54,440	48,720	45,160	41,620	34,720	28,240	25,220	22,390

110°F Ambient

R*O130E4S**	-	-	-	9,890	9,000	8,120	6,370	4,670	-	-
R*O150E4S**	-	-	12,110	12,410	11,250	10,110	7,890	5,760	-	-
R*O180E4S**	-	-	13,550	13,980	12,690	11,420	8,950	6,550	-	-
R*O200E4S**	-	-	16,690	17,320	15,660	14,040	10,940	7,970	-	-
R*O250E4S**	-	-	18,460	19,330	17,520	15,730	12,270	8,960	-	-
R*O300E4S**	-	-	28,560	26,620	24,040	21,550	16,750	12,180	-	-
R*O350E4S**	-	-	29,720	28,950	26,240	23,650	18,730	13,960	-	-
R*O400E4S**	-	-	35,720	32,560	29,480	26,460	20,630	15,060	-	-
R*O450E4S**	-	-	39,180	36,720	33,170	29,730	23,100	16,810	-	-
R*O500E4S**	-	-	44,180	43,790	39,400	35,210	27,630	22,580	-	-
R*O600E4S**	-	-	46,430	46,200	42,770	39,380	32,800	26,600	-	-

* Each asterisk represents a variable character based upon model, voltage, and vintage ordered. See page 4 for nomenclature.

‡ Multiply capacity by .83 when used with 50 Hz power.

20°F Superheat Maximum

NEXT-GEN MINICON CONDENSING UNITS

Capacity Data (BTUH) - Extended Medium Temperature R448A/449A Scroll - 60 Hz[‡]

SUCTION TEMPERATURE

MODEL	45°F	40°F	35°F	30°F	25°F	20°F	10°F	0°F	-5°F	-10°F
-------	------	------	------	------	------	------	------	-----	------	-------

90°F Ambient

R*O130E4S**	15,870	14,100	12,600	11,100	10,030	9,070	7,410	6,000	5,340	4,710
R*O150E4S**	19,740	17,570	15,670	13,960	12,580	11,350	9,220	7,420	6,600	5,800
R*O180E4S**	22,150	19,740	17,630	15,710	14,180	12,810	10,440	8,430	7,490	6,600
R*O200E4S**	27,060	24,100	21,530	19,370	17,440	15,700	12,740	10,250	9,120	8,010
R*O250E4S**	30,050	26,760	23,870	21,560	19,430	17,510	14,230	11,470	10,200	8,970
R*O300E4S**	42,610	38,750	35,180	31,920	28,900	26,060	20,890	16,400	14,380	12,500
R*O350E4S**	47,490	42,790	38,490	34,140	30,840	27,810	22,470	18,070	16,200	14,140
R*O400E4S**	53,710	48,750	44,280	39,920	36,200	32,690	26,310	20,680	18,150	15,800
R*O450E4S**	60,040	54,540	49,500	44,720	40,500	36,510	29,280	22,980	20,150	17,520
R*O500E4S**	64,350	58,760	53,630	49,760	45,040	40,590	32,460	27,180	24,660	22,230
R*O600E4S**	73,700	66,920	60,600	52,450	48,680	45,020	38,040	31,600	28,610	25,790

95°F Ambient

R*O130E4S**	15,210	13,500	12,050	10,700	9,680	8,750	7,160	5,820	5,210	4,630
R*O150E4S**	18,960	16,860	15,020	13,480	12,140	10,950	8,910	7,210	6,440	5,690
R*O180E4S**	21,260	18,930	16,880	15,170	13,690	12,360	10,090	8,180	7,320	6,480
R*O200E4S**	26,020	23,140	20,650	18,730	16,840	15,160	12,320	9,960	8,910	7,870
R*O250E4S**	28,880	25,670	22,880	20,840	18,770	16,900	13,750	11,140	9,950	8,810
R*O300E4S**	40,980	37,270	33,840	30,910	27,960	25,190	20,120	15,690	13,700	11,830
R*O350E4S**	45,770	41,160	36,940	33,020	29,760	26,770	21,550	17,270	15,460	13,370
R*O400E4S**	51,620	46,860	42,560	38,640	35,030	31,590	25,330	19,790	17,290	14,950
R*O450E4S**	57,760	52,480	47,620	43,310	39,190	35,290	28,190	21,990	19,190	16,580
R*O500E4S**	61,270	55,970	51,090	47,730	43,160	38,850	31,460	26,370	23,930	21,570
R*O600E4S**	70,140	63,700	57,700	50,910	47,250	43,700	36,940	30,710	27,810	25,080

100°F Ambient

R*O130E4S**	14,520	12,860	11,460	10,290	9,310	8,400	6,880	5,630	5,070	4,520
R*O150E4S**	18,150	16,100	14,320	12,970	11,680	10,530	8,570	6,970	6,250	5,570
R*O180E4S**	20,320	18,060	16,080	14,600	13,150	11,870	9,700	7,920	7,110	6,330
R*O200E4S**	24,900	22,100	19,690	18,050	16,220	14,580	11,860	9,640	8,650	7,700
R*O250E4S**	27,640	24,530	21,820	20,070	18,060	16,260	13,240	10,780	9,680	8,620
R*O300E4S**	39,310	35,750	32,440	29,870	26,990	24,280	19,310	14,940	12,960	11,100
R*O350E4S**	43,900	39,370	35,230	31,790	28,560	25,620	20,500	16,350	14,620	12,550
R*O400E4S**	49,470	44,910	40,770	37,330	33,800	30,440	24,300	18,840	16,360	14,030
R*O450E4S**	55,410	50,350	45,680	41,860	37,840	34,030	27,050	20,920	18,150	15,560
R*O500E4S**	58,150	53,110	48,490	45,780	41,340	37,180	30,430	25,500	23,140	20,870
R*O600E4S**	66,520	60,420	54,730	49,330	45,790	42,350	35,820	29,790	26,980	24,330

110°F Ambient

R*O130E4S**	-	-	-	9,390	8,460	7,640	6,250	5,160	-	-
R*O150E4S**	-	-	12,180	11,850	10,630	9,560	7,780	6,390	-	-
R*O180E4S**	-	-	13,630	13,330	11,980	10,790	8,820	7,250	-	-
R*O200E4S**	-	-	16,790	16,510	14,790	13,270	10,790	8,840	-	-
R*O250E4S**	-	-	18,570	18,370	16,480	14,800	12,050	9,890	-	-
R*O300E4S**	-	-	28,220	27,700	24,950	22,340	17,530	13,250	-	-
R*O350E4S**	-	-	29,840	28,860	25,710	22,850	17,940	14,040	-	-
R*O400E4S**	-	-	35,360	34,570	31,210	28,000	22,040	16,710	-	-
R*O450E4S**	-	-	39,760	38,810	34,960	31,320	24,560	18,560	-	-
R*O500E4S**	-	-	42,350	41,920	36,460	34,000	28,210	23,650	-	-
R*O600E4S**	-	-	46,550	46,050	42,720	39,510	33,430	27,820	-	-

* Each asterisk represents a variable character based upon model, voltage, and vintage ordered. See page 4 for nomenclature.

‡ Multiply capacity by .83 when used with 50 Hz power.

20°F Superheat Maximum

R-SERIES

Capacity Data (BTUH) - Low Temperature R404A Hermetic - 60 Hz[‡]

SUCTION TEMPERATURE

MODEL	0°F	-5°F	-10°F	-15°F	-20°F	-25°F	-30°F
90°F Ambient							
R*H100L44**	6,450	5,490	4,640	3,880	3,170	2,500	1,850
R*H150L44**	10,120	8,920	7,750	6,600	5,480	4,440	3,480
R*H200L44**	15,650	13,810	11,990	10,250	8,580	7,000	5,530
R*H300L44**	20,270	18,020	15,830	13,690	11,620	9,600	7,630
R*H055E44** [^]	3,390	2,940	2,520	2,100	1,700	1,310	—
R*H080E44** [^]	3,960	3,420	2,930	2,480	2,070	1,690	—
R*H090E44** [^]	5,250	4,590	3,980	3,400	2,870	2,370	—
R*H100E44** [^]	5,250	4,560	3,920	3,350	2,830	2,360	—
R*H125E44** [^]	7,640	6,690	5,820	5,020	4,300	3,680	—
R*H150E44** [^]	7,530	6,270	5,110	4,050	3,130	2,340	—
R*H200E44** [^]	8,640	7,270	5,970	4,750	3,580	2,470	—
R*H250E44** [^]	10,980	9,350	7,840	6,460	5,230	4,150	—
R*H300E44** [^]	13,300	11,240	9,330	7,610	6,120	4,890	—
R*H325E44** [^]	16,050	13,740	11,600	9,580	7,610	5,670	—
95°F Ambient							
R*H100L44**	5,920	5,000	4,210	3,490	2,830	2,200	1,580
R*H150L44**	9,470	8,320	7,200	6,090	5,030	4,030	3,130
R*H200L44**	14,690	12,910	11,180	9,510	7,920	6,420	5,030
R*H300L44**	19,040	16,890	14,800	12,760	10,780	8,840	6,950
R*H055E44** [^]	3,210	2,780	2,370	1,970	1,580	1,200	—
R*H080E44** [^]	3,720	3,200	2,730	2,300	1,900	1,540	—
R*H090E44** [^]	4,970	4,340	3,740	3,190	2,670	2,200	—
R*H100E44** [^]	4,970	4,310	3,690	3,140	2,640	2,190	—
R*H125E44** [^]	7,230	6,320	5,470	4,710	4,020	3,420	—
R*H150E44** [^]	6,920	5,720	4,610	3,610	2,740	1,990	—
R*H200E44** [^]	7,970	6,650	5,410	4,240	3,130	2,070	—
R*H250E44** [^]	10,240	8,690	7,250	5,940	4,760	3,740	—
R*H300E44** [^]	12,310	10,340	8,530	6,910	5,520	4,370	—
R*H325E44** [^]	14,770	12,570	10,530	8,590	6,720	4,870	—
100°F Ambient							
R*H100L44**	5,360	4,500	3,770	3,100	2,480	1,900	1,320
R*H150L44**	8,820	7,710	6,650	5,600	4,580	3,640	2,790
R*H200L44**	13,740	12,030	10,380	8,790	7,280	5,860	4,540
R*H300L44**	17,810	15,770	13,790	11,840	9,950	8,100	6,280
R*H055E44** [^]	3,030	2,620	2,220	1,830	1,460	1,090	—
R*H080E44** [^]	3,490	2,990	2,540	2,120	1,740	1,400	—
R*H090E44** [^]	4,700	4,090	3,510	2,980	2,480	2,030	—
R*H100E44** [^]	4,690	4,050	3,460	2,930	2,450	2,020	—
R*H125E44** [^]	6,810	5,930	5,120	4,390	3,730	3,150	—
R*H150E44** [^]	6,320	5,170	4,120	3,170	2,350	1,640	—
R*H200E44** [^]	7,300	6,040	4,860	3,750	2,700	1,690	—
R*H250E44** [^]	9,510	8,040	6,670	5,420	4,300	3,320	—
R*H300E44** [^]	11,330	9,470	7,760	6,240	4,940	3,890	—
R*H325E44** [^]	13,510	11,410	9,460	7,620	5,840	4,080	—
110°F Ambient							
R*H100L44**	4,240	3,500	2,880	2,320	1,810	1,320	850
R*H150L44**	7,510	6,520	5,570	4,630	3,730	2,900	2,160
R*H200L44**	11,850	10,300	8,810	7,370	6,020	4,760	3,610
R*H300L44**	15,390	13,560	11,780	10,040	8,330	6,660	5,010
R*H055E44** [^]	2,660	2,280	1,920	1,560	1,220	880	—
R*H080E44** [^]	3,040	2,590	2,180	1,810	1,470	1,150	—
R*H090E44** [^]	4,150	3,590	3,070	2,580	2,130	1,710	—
R*H100E44** [^]	4,100	3,520	2,980	2,490	2,060	1,660	—
R*H125E44** [^]	5,960	5,160	4,420	3,740	3,140	2,620	—
R*H150E44** [^]	5,120	4,090	3,140	2,300	1,570	940	—
R*H200E44** [^]	6,000	4,870	3,810	2,830	1,900	1,030	—
R*H250E44** [^]	8,050	6,730	5,500	4,390	3,390	2,520	—
R*H300E44** [^]	9,460	7,800	6,290	4,970	3,870	3,000	—
R*H325E44** [^]	11,050	9,150	7,380	5,710	4,110	2,510	—

* Each asterisk represents a variable character based upon model, voltage, and vintage ordered. See page 4 for nomenclature.

‡ Multiply capacity by .83 when used with 50 Hz power.

[^] An optional Electric Defrost kit must be ordered in lieu of the standard Air Defrost Timer when extended range medium temperature models are used for low temperature applications.

NEXT-GEN MINICON CONDENSING UNITS

Capacity Data (BTUH) - Low Temperature R404A Scroll - 60 Hz[‡]

SUCTION TEMPERATURE

MODEL	0°F	-5°F	-10°F	-15°F	-20°F	-25°F	-30°F	-35°F	-40°F
-------	-----	------	-------	-------	-------	-------	-------	-------	-------

90°F Ambient

R*O200L4S**	11,290	10,200	9,180	8,220	7,320	6,480	5,700	4,990	4,320
R*O250L4S**	14,770	13,290	11,910	10,640	9,470	8,390	7,400	6,500	5,670
R*O300L4S**	16,190	14,610	13,130	11,760	10,500	9,320	8,240	7,230	6,290
R*O350L4S**	19,400	17,560	15,830	14,190	12,670	11,260	9,950	8,750	7,630
R*O400L4S**	23,970	21,490	19,190	17,060	15,080	13,260	11,590	10,090	8,720
R*O500L4S**	28,630	25,820	23,200	20,770	18,520	16,450	14,530	12,760	11,150
R*O600L4S**	32,720	29,530	26,560	23,790	21,220	18,850	16,660	14,630	12,760

95°F Ambient

R*O200L4S**	10,810	9,770	8,790	7,870	7,020	6,210	5,460	4,770	4,130
R*O250L4S**	14,130	12,720	11,410	10,190	9,070	8,040	7,090	6,210	5,420
R*O300L4S**	15,480	13,980	12,570	11,260	10,050	8,930	7,890	6,920	6,020
R*O350L4S**	18,530	16,780	15,130	13,580	12,120	10,780	9,530	8,380	7,310
R*O400L4S**	22,930	20,550	18,340	16,300	14,390	12,640	11,040	9,580	8,270
R*O500L4S**	27,350	24,660	22,160	19,840	17,690	15,710	13,880	12,200	10,650
R*O600L4S**	31,310	28,270	25,440	22,800	20,350	18,080	15,980	14,040	12,240

100°F Ambient

R*O200L4S**	10,320	9,330	8,400	7,530	6,710	5,940	5,220	4,550	3,930
R*O250L4S**	13,490	12,140	10,890	9,730	8,660	7,670	6,760	5,920	5,160
R*O300L4S**	14,760	13,340	11,990	10,750	9,590	8,520	7,530	6,600	5,740
R*O350L4S**	17,650	15,980	14,410	12,940	11,560	10,280	9,090	8,000	6,980
R*O400L4S**	21,860	19,590	17,480	15,520	13,700	12,020	10,480	9,090	7,830
R*O500L4S**	26,040	23,480	21,100	18,890	16,850	14,960	13,220	11,620	10,150
R*O600L4S**	29,890	27,000	24,300	21,790	19,450	17,290	15,280	13,430	11,710

105°F Ambient

R*O200L4S**	9,830	8,890	8,010	7,180	6,400	5,670	4,980	4,340	3,740
R*O250L4S**	12,830	11,550	10,350	9,250	8,230	7,290	6,420	5,620	4,890
R*O300L4S**	14,040	12,680	11,410	10,220	9,120	8,100	7,160	6,280	5,450
R*O350L4S**	16,740	15,160	13,670	12,290	10,980	9,760	8,640	7,600	6,640
R*O400L4S**	20,770	18,610	16,600	14,730	13,010	11,410	9,940	8,610	7,400
R*O500L4S**	24,710	22,280	20,020	17,920	15,990	14,200	12,550	11,020	9,620
R*O600L4S**	28,450	25,700	23,140	20,760	18,540	16,480	14,580	12,810	11,180

110°F Ambient

R*O200L4S**	9,340	8,450	7,610	6,830	6,090	5,390	4,740	4,130	3,550
R*O250L4S**	12,150	10,940	9,810	8,760	7,790	6,900	6,070	5,320	4,620
R*O300L4S**	13,300	12,010	10,810	9,690	8,650	7,680	6,780	5,940	5,160
R*O350L4S**	15,820	14,320	12,920	11,610	10,380	9,230	8,170	7,190	6,280
R*O400L4S**	19,670	17,630	15,720	13,950	12,310	10,800	9,410	8,150	7,000
R*O500L4S**	23,360	21,060	18,920	16,940	15,100	13,410	11,850	10,410	9,090
R*O600L4S**	26,990	24,390	21,960	19,700	17,610	15,660	13,850	12,180	10,630

* Each asterisk represents a variable character based upon model, voltage, and vintage ordered. See page 4 for nomenclature.

‡ Multiply capacity by .83 when used with 50 Hz power.

R-SERIES

Capacity Data (BTUH) - Low Temperature R407A Scroll - 60 Hz[‡]

SUCTION TEMPERATURE

MODEL	0°F	-5°F	-10°F	-15°F	-20°F	-25°F	-30°F	-35°F	-40°F
-------	-----	------	-------	-------	-------	-------	-------	-------	-------

90°F Ambient

R*O200L4S**	9,620	8,470	7,440	6,510	5,690	4,950	4,280	3,690	3,160
R*O250L4S**	12,820	11,450	10,170	8,990	7,900	6,910	6,000	5,190	4,470
R*O300L4S**	14,170	12,830	11,470	10,140	8,870	7,710	6,690	5,840	5,190
R*O350L4S**	17,510	15,880	14,210	12,560	10,990	9,530	8,260	7,200	6,410
R*O400L4S**	20,980	18,640	16,440	14,390	12,520	10,860	9,440	8,300	7,450
R*O500L4S**	25,620	22,750	20,070	17,620	15,420	13,480	11,830	10,490	9,490
R*O600L4S**	30,490	27,200	24,110	21,220	18,600	16,270	14,260	12,600	11,320

95°F Ambient

R*O200L4S**	9,380	8,250	7,240	6,340	5,530	4,800	4,160	3,570	3,050
R*O250L4S**	12,390	11,060	9,830	8,690	7,630	6,670	5,790	5,000	4,300
R*O300L4S**	13,700	12,410	11,110	9,820	8,590	7,460	6,460	5,630	4,990
R*O350L4S**	16,920	15,360	13,750	12,160	10,630	9,220	7,980	6,950	6,170
R*O400L4S**	20,300	18,000	15,830	13,830	12,020	10,420	9,070	7,990	7,210
R*O500L4S**	24,790	21,990	19,370	16,980	14,830	12,960	11,370	10,080	9,130
R*O600L4S**	29,540	26,330	23,310	20,500	17,950	15,690	13,750	12,160	10,930

100°F Ambient

R*O200L4S**	9,130	8,030	7,040	6,160	5,370	4,660	4,030	3,460	2,950
R*O250L4S**	11,940	10,660	9,470	8,370	7,350	6,420	5,570	4,810	4,130
R*O300L4S**	13,240	12,000	10,740	9,500	8,310	7,220	6,240	5,430	4,800
R*O350L4S**	16,330	14,830	13,290	11,750	10,280	8,920	7,710	6,700	5,930
R*O400L4S**	19,610	17,340	15,220	13,270	11,510	9,980	8,690	7,680	6,960
R*O500L4S**	23,950	21,200	18,650	16,320	14,230	12,410	10,880	9,650	8,740
R*O600L4S**	28,580	25,440	22,500	19,770	17,290	15,100	13,230	11,690	10,530

105°F Ambient

R*O200L4S**	8,870	7,800	6,840	5,980	5,210	4,520	3,900	3,340	2,840
R*O250L4S**	11,480	10,260	9,110	8,050	7,070	6,170	5,350	4,610	3,950
R*O300L4S**	12,770	11,590	10,380	9,190	8,040	6,970	6,030	5,230	4,610
R*O350L4S**	15,730	14,300	12,820	11,350	9,930	8,610	7,440	6,460	5,710
R*O400L4S**	18,890	16,670	14,600	12,700	11,000	9,520	8,300	7,350	6,700
R*O500L4S**	23,080	20,400	17,910	15,640	13,610	11,850	10,370	9,190	8,320
R*O600L4S**	27,600	24,540	21,670	19,020	16,620	14,500	12,690	11,210	10,100

110°F Ambient

R*O200L4S**	8,620	7,580	6,640	5,800	5,050	4,370	3,770	3,230	2,740
R*O250L4S**	11,010	9,840	8,730	7,710	6,770	5,900	5,120	4,400	3,770
R*O300L4S**	12,310	11,180	10,020	8,870	7,770	6,740	5,820	5,040	4,430
R*O350L4S**	15,130	13,760	12,350	10,940	9,580	8,310	7,170	6,220	5,480
R*O400L4S**	18,150	15,970	13,950	12,110	10,470	9,060	7,900	7,010	6,430
R*O500L4S**	22,180	19,570	17,140	14,930	12,970	11,260	9,840	8,710	7,890
R*O600L4S**	26,600	23,620	20,830	18,260	15,930	13,870	12,130	10,710	9,650

* Each asterisk represents a variable character based upon model, voltage, and vintage ordered. See page 4 for nomenclature.

‡ Multiply capacity by .83 when used with 50 Hz power.

NEXT-GEN MINICON CONDENSING UNITS

Capacity Data (BTUH) - Low Temperature R407C Scroll - 60 Hz[‡]

SUCTION TEMPERATURE

MODEL	0°F	-5°F	-10°F	-15°F	-20°F	-25°F	-30°F	-35°F	-40°F
-------	-----	------	-------	-------	-------	-------	-------	-------	-------

90°F Ambient

R*O200L4S**	9,090	7,940	6,950	6,070	5,300	4,620	4,000	3,450	2,930
R*O250L4S**	12,220	10,850	9,610	8,490	7,460	6,530	5,670	4,890	4,170
R*O300L4S**	13,500	12,160	10,840	9,570	8,380	7,290	6,320	5,500	4,840
R*O350L4S**	16,600	15,020	13,420	11,840	10,340	8,950	7,750	6,760	6,040
R*O400L4S**	19,620	17,420	15,330	13,390	11,610	10,040	8,700	7,650	6,890
R*O500L4S**	23,910	21,270	18,760	16,440	14,340	12,480	10,910	9,660	8,770
R*O600L4S**	28,450	25,410	22,510	19,780	17,290	15,080	13,190	11,660	10,530

95°F Ambient

R*O200L4S**	8,880	7,750	6,770	5,920	5,170	4,490	3,900	3,350	2,840
R*O250L4S**	11,810	10,490	9,300	8,210	7,210	6,310	5,480	4,720	4,010
R*O300L4S**	13,060	11,770	10,510	9,280	8,120	7,060	6,110	5,310	4,660
R*O350L4S**	16,050	14,540	12,990	11,470	10,010	8,670	7,490	6,530	5,820
R*O400L4S**	19,000	16,830	14,770	12,870	11,150	9,640	8,370	7,370	6,680
R*O500L4S**	23,160	20,580	18,120	15,850	13,800	12,010	10,490	9,290	8,450
R*O600L4S**	27,590	24,620	21,780	19,120	16,700	14,560	12,730	11,260	10,180

100°F Ambient

R*O200L4S**	8,680	7,580	6,620	5,790	5,050	4,390	3,810	3,260	2,760
R*O250L4S**	11,410	10,130	8,970	7,920	6,960	6,090	5,290	4,550	3,870
R*O300L4S**	12,650	11,400	10,170	8,990	7,870	6,850	5,920	5,140	4,500
R*O350L4S**	15,530	14,070	12,580	11,100	9,690	8,390	7,250	6,310	5,600
R*O400L4S**	18,390	16,240	14,230	12,370	10,700	9,240	8,030	7,090	6,460
R*O500L4S**	22,430	19,880	17,490	15,270	13,270	11,520	10,060	8,910	8,110
R*O600L4S**	26,770	23,840	21,070	18,480	16,120	14,040	12,280	10,860	9,840

105°F Ambient

R*O200L4S**	8,470	7,400	6,470	5,650	4,930	4,290	3,710	3,170	2,660
R*O250L4S**	10,990	9,770	8,650	7,630	6,710	5,870	5,090	4,380	3,720
R*O300L4S**	12,230	11,030	9,850	8,710	7,630	6,630	5,740	4,970	4,340
R*O350L4S**	15,000	13,600	12,160	10,740	9,370	8,110	7,000	6,090	5,400
R*O400L4S**	17,750	15,650	13,680	11,860	10,240	8,830	7,680	6,800	6,230
R*O500L4S**	21,670	19,180	16,830	14,670	12,720	11,020	9,610	8,510	7,750
R*O600L4S**	25,920	23,050	20,340	17,820	15,520	13,510	11,800	10,440	9,480

110°F Ambient

R*O200L4S**	8,270	7,230	6,310	5,510	4,800	4,170	3,600	3,080	2,570
R*O250L4S**	10,560	9,380	8,300	7,320	6,440	5,630	4,890	4,200	3,570
R*O300L4S**	11,810	10,660	9,530	8,430	7,390	6,430	5,560	4,810	4,190
R*O350L4S**	14,480	13,120	11,740	10,370	9,050	7,840	6,750	5,860	5,190
R*O400L4S**	17,100	15,030	13,100	11,340	9,780	8,430	7,340	6,510	6,000
R*O500L4S**	20,880	18,450	16,150	14,040	12,150	10,500	9,140	8,090	7,380
R*O600L4S**	25,050	22,250	19,600	17,140	14,910	12,940	11,300	10,000	9,090

* Each asterisk represents a variable character based upon model, voltage, and vintage ordered. See page 4 for nomenclature.

‡ Multiply capacity by .83 when used with 50 Hz power.

R-SERIES

Capacity Data (BTUH) - Low Temperature R448A/449A Scroll - 60 Hz[‡]

SUCTION TEMPERATURE

MODEL	0°F	-5°F	-10°F	-15°F	-20°F	-25°F	-30°F	-35°F	-40°F
-------	-----	------	-------	-------	-------	-------	-------	-------	-------

90°F Ambient

R*O200L4S**	9,960	8,730	7,650	6,690	5,850	5,100	4,440	3,860	3,360
R*O250L4S**	13,370	11,930	10,590	9,360	8,240	7,220	6,270	5,430	4,660
R*O300L4S**	14,840	13,280	11,830	10,500	9,270	8,160	7,160	6,240	5,400
R*O350L4S**	18,310	16,420	14,640	12,990	11,490	10,090	8,850	7,710	6,690
R*O400L4S**	22,470	19,930	17,610	15,470	13,530	11,780	10,230	8,890	7,740
R*O500L4S**	27,380	24,340	21,540	19,000	16,700	14,640	12,810	11,200	9,830
R*O600L4S**	32,560	29,050	25,830	22,850	20,140	17,690	15,490	13,520	11,790

95°F Ambient

R*O200L4S**	9,740	8,540	7,480	6,540	5,710	4,970	4,340	3,760	3,250
R*O250L4S**	12,950	11,550	10,260	9,080	7,980	6,990	6,070	5,240	4,500
R*O300L4S**	14,400	12,870	11,480	10,180	9,000	7,920	6,940	6,050	5,230
R*O350L4S**	17,760	15,920	14,200	12,610	11,140	9,800	8,580	7,490	6,490
R*O400L4S**	21,600	19,150	16,890	14,840	12,990	11,330	9,870	8,610	7,550
R*O500L4S**	26,340	23,420	20,720	18,280	16,070	14,120	12,380	10,850	9,560
R*O600L4S**	31,360	27,990	24,890	22,040	19,440	17,110	15,020	13,160	11,520

100°F Ambient

R*O200L4S**	9,520	8,350	7,310	6,390	5,580	4,860	4,230	3,670	3,170
R*O250L4S**	12,520	11,170	9,920	8,780	7,720	6,760	5,870	5,070	4,340
R*O300L4S**	13,950	12,470	11,110	9,860	8,710	7,680	6,720	5,860	5,060
R*O350L4S**	17,190	15,400	13,740	12,200	10,790	9,500	8,320	7,250	6,290
R*O400L4S**	20,710	18,340	16,170	14,210	12,450	10,890	9,520	8,360	7,380
R*O500L4S**	25,260	22,450	19,880	17,550	15,440	13,580	11,940	10,510	9,290
R*O600L4S**	30,130	26,890	23,930	21,210	18,750	16,530	14,560	12,810	11,280

105°F Ambient

R*O200L4S**	9,290	8,150	7,140	6,250	5,450	4,750	4,130	3,570	3,080
R*O250L4S**	12,080	10,800	9,590	8,490	7,470	6,540	5,680	4,900	4,180
R*O300L4S**	13,480	12,060	10,740	9,540	8,440	7,420	6,510	5,670	4,890
R*O350L4S**	16,610	14,880	13,270	11,790	10,430	9,180	8,050	7,020	6,090
R*O400L4S**	19,770	17,500	15,440	13,580	11,910	10,450	9,190	8,120	7,240
R*O500L4S**	24,140	21,460	19,010	16,800	14,810	13,050	11,510	10,180	9,040
R*O600L4S**	28,850	25,770	22,940	20,380	18,050	15,970	14,120	12,480	11,060

110°F Ambient

R*O200L4S**	9,080	7,970	6,980	6,100	5,330	4,640	4,030	3,500	3,010
R*O250L4S**	11,650	10,410	9,250	8,190	7,210	6,310	5,490	4,720	4,030
R*O300L4S**	13,020	11,640	10,360	9,200	8,150	7,180	6,290	5,480	4,730
R*O350L4S**	16,010	14,330	12,780	11,360	10,050	8,860	7,760	6,780	5,860
R*O400L4S**	18,810	16,640	14,690	12,940	11,380	10,030	8,880	7,900	7,140
R*O500L4S**	22,980	20,440	18,120	16,030	14,170	12,520	11,100	9,870	8,830
R*O600L4S**	27,540	24,620	21,950	19,540	17,370	15,410	13,700	12,190	10,880

* Each asterisk represents a variable character based upon model, voltage, and vintage ordered. See page 4 for nomenclature.

‡ Multiply capacity by .83 when used with 50 Hz power.

NEXT-GEN MINICON CONDENSING UNITS

Electrical Data - Hermetic

BASE MODEL NUMBER	COMP. MODEL	COMPRESSOR		COND. FAN FLA	AIR DEFROST		MAX. EVAP. FAN AMPS†	MAX DEFROST AMPS†	ELECTRIC DEFROST		ELECTRIC DEFROST KIT†
		RLA	LRA		MCA	MOPD			MCA	MOPD	
200-220V/1/50 Hz[^]											
R*H055E44**	RST45C1E	5.1	26.5	0.5	15.0	15	4.0	15.0	19.7	20	ED-5
R*H080E44**	RST55C1E	6.3	33.7	0.5	15.0	15	4.0	15.0	19.7	20	ED-5
R*H090E44**	RST64C1E	8.5	43.0	0.5	15.0	20	4.0	15.0	19.7	20	ED-5
R*H150E44**	CS10K6E	9.8	56.0	1.0	15.0	20	6.0	20.0	26.0	30	ED-6
R*H200E44**	CS12K6E	9.8	56.0	1.0	15.0	20	6.0	20.0	26.0	30	ED-6
R*H250E44**	CS14K6E	11.2	61.0	1.0	16.0	25	10.0	25.0	32.2	35	ED-7
R*H300E44**	CS18K6E	14.4	82.0	1.0	20.0	30	10.0	25.0	32.2	40	ED-7
R*H325E44**	CS20K6E	13.8	75.9	3.1	21.3	35	12.0	30.0	38.5	45	ED-10
R*H100L44**	CF04K6E	8.6	59.2	0.5	-	-	4.0	15.0	19.7	20	ED-5
R*H150L44**	CF06K6E	10.3	59.2	0.5	-	-	4.0	15.0	19.7	25	ED-5
R*H200L44**	CF09K6E	15.0	87.0	1.0	-	-	6.0	25.0	32.2	40	ED-7
R*H300L44**	CF12K6E	18.4	105.0	1.0	-	-	10.0	25.0	35.0	50	ED-7
208-230V/1/60 Hz											
R*H055E44**	RST45C1E	4.6	26.5	0.5	15.0	15	4.0	15.0	19.7	20	ED-5
R*H080E44**	RST55C1E	6.1	33.7	0.5	15.0	15	4.0	15.0	19.7	20	ED-5
R*H090E44**	RST64C1E	8.1	43.0	0.5	15.0	15	4.0	15.0	19.7	20	ED-5
R*H100E44**	RST70C1E	6.9	46.0	0.5	15.0	15	4.0	15.0	19.7	20	ED-5
R*H125E44**	RST97C1E	9.0	51.0	0.5	15.0	20	4.0	15.0	19.7	25	ED-5
R*H150E44**	CS10K6E	9.8	56.0	1.0	15.0	20	6.0	20.0	26.0	30	ED-6
R*H200E44**	CS12K6E	9.8	56.0	1.0	15.0	20	6.0	20.0	26.0	30	ED-6
R*H250E44**	CS14K6E	11.2	61.0	1.0	16.0	25	10.0	25.0	32.2	35	ED-7
R*H300E44**	CS18K6E	14.4	82.0	1.0	20.0	30	10.0	25.0	32.2	40	ED-7
R*H325E44**	CS20K6E	16.7	96.0	3.1	24.9	40	12.0	30.0	38.5	50	ED-10
R*H100L44**	CF04K6E	8.6	59.2	0.5	-	-	4.0	15.0	19.7	20	ED-5
R*H150L44**	CF06K6E	10.3	59.2	0.5	-	-	4.0	15.0	19.7	25	ED-5
R*H200L44**	CF09K6E	15.0	87.0	1.0	-	-	6.0	25.0	32.2	40	ED-7
R*H300L44**	CF12K6E	18.4	105.0	1.0	-	-	10.0	25.0	35.0	50	ED-7
208-230V/3/60 Hz, 200-220V/3/50 Hz[‡]											
R*H100E44** ^{^^}	RST70C1E	4.9	36.0	0.5	15.0	15	4.0	15.0	19.7	20	ED-5
R*H125E44** ^{^^}	RST97C1E	5.4	36.0	1.0	15.0	15	6.0	15.0	19.7	20	ED-5
R*H150E44** ^{^^}	CS10K6E	6.7	51.0	1.0	15.0	15	6.0	15.0	19.7	20	ED-5
R*H200E44** ^{^^}	CS12K6E	6.7	51.0	1.0	15.0	15	6.0	15.0	19.7	20	ED-5
R*H250E44**	CS14K6E	8.2	55.0	1.0	15.0	20	10.0	20.0	26.0	30	ED-6
R*H300E44**	CS18K6E	9.4	65.5	1.0	15.0	20	10.0	20.0	26.0	30	ED-6
R*H325E44**	CS20K6E	10.2	75.0	3.1	16.8	25	12.0	25.0	32.2	35	ED-7
R*H100L44**	CF04K6E	5.7	52.0	0.5	-	-	4.0	15.0	19.7	20	ED-5
R*H150L44**	CF06K6E	6.3	52.0	0.5	-	-	4.0	15.0	19.7	20	ED-5
R*H200L44**	CF09K6E	9.2	72.2	1.0	-	-	6.0	15.0	19.7	25	ED-5
R*H300L44**	CF12K6E	11.0	85.0	1.0	-	-	10.0	25.0	32.2	35	ED-7
460V/3/60 Hz, 380V/3/50 Hz^{‡‡}											
R*H150E44**	CS10K6E	3.2	25.0	0.8	15.0	15	3.0	15.0	19.7	20	ED-17
R*H250E44**	CS14K6E	4.2	28.0	0.8	15.0	15	5.0	15.0	19.7	20	ED-17
R*H300E44**	CS18K6E	4.2	33.0	0.8	15.0	15	5.0	15.0	19.7	20	ED-17
R*H325E44**	CS20K6E	4.6	40.0	2.5	15.0	15	6.0	15.0	19.7	20	ED-17
R*H150L44**	CF06K6E	3.3	25.4	0.4	-	-	2.0	15.0	19.7	20	ED-17
R*H200L44**	CF09K6E	4.9	35.8	0.8	-	-	3.0	15.0	19.7	20	ED-17
R*H300L44**	CF12K6E	5.9	42.0	0.8	-	-	5.0	15.0	19.7	20	ED-17

* Each asterisk represents a variable character based upon model, voltage, and vintage ordered. See page 4 for nomenclature.

RLA = Rated Load Amps LRA = Locked Rotor Amps MCA = Minimum Circuit Ampacity MOPD = Maximum Overcurrent Protection
MCA includes 1 amp allowance for control circuit requirement.

† Note: Maximum Evap. fan amps and maximum defrost amps are shown to provide ratings when electric defrost is required and is an optional feature. Maximum Amp value used to determine MOPD. Exceeding these values invalidates the listed MOPD and requires a revised calculation. Contact Application Engineering when amp draw requirements deviate from the chart values.

[^] R*H100E44 is not available in 200-220V/1/50 Hz.

^{^^} R*H100E44, R*H125E44, R*H150E44, and R*H200E44 are not available in 200-220V/3/50 Hz.

[‡] R*H055E44, R*H080E44, and R*H090E44 are not available in 208-230V/3/60 Hz.

^{‡‡} R*H055E44, R*H080E44, R*H090E44, R*H100L44, R*H125E44 and R*H200E44 are not available in 460V/3/60 Hz.

R-SERIES

Electrical Data - Scroll

BASE MODEL NUMBER	COMP. MODEL	COMPRESSOR		COND. FAN FLA	AIR DEFROST		MAX. EVAP. FAN AMPS†	MAX DEFROST AMPS†	ELECTRIC DEFROST		ELECTRIC DEFROST KIT†
		RLA	LRA		MCA	MOPD			MCA	MOPD	
200-220V/1/50 Hz[^]											
R*O130E4S**	ZS09KAE	8.0	45.0	0.5	15.0	15	4.0	15.0	19.7	20	ED-5
R*O150E4S**	ZS11KAE	9.2	45.0	1.0	15.0	20	6.0	20.0	26.0	30	ED-6
R*O180E4S**	ZS13KAE	10.1	54.0	1.0	15.0	20	6.0	20.0	26.0	30	ED-6
R*O200E4S**	ZS15KAE	12.4	61.0	1.0	17.5	25	10.0	25.0	32.2	35	ED-7
R*O250E4S**	ZS19KAE	14.5	79.0	1.0	20.1	30	10.0	25.0	32.2	40	ED-7
R*O300E4S**	ZS21KAE	17.2	87.0	3.1	25.6	40	12.0	30.0	38.5	50	ED-10
R*O350E4S**	ZS26KAE	17.8	122.0	3.1	26.3	40	12.0	30.0	38.5	50	ED-10
R*O400E4S**	ZS29KAE	19.4	133.0	3.1	28.3	45	12.0	30.0	40.3	50	ED-10
R*O450E4S**	ZS33KAE	21.9	133.0	3.1	31.4	50	12.0	30.0	43.4	60	ED-10
R*O500E4S**	ZS38K4E	28.5	169.0	3.1	39.7	60	12.0	30.0	51.7	60	ED-10

208-230V/1/60 Hz[^]

R*O130E4S**	ZS09KAE	9.0	40.3	0.5	15.0	20	4.0	15.0	19.7	25	ED-5
R*O150E4S**	ZS11KAE	11.3	55.0	1.0	16.1	25	6.0	20.0	26.0	30	ED-6
R*O180E4S**	ZS13KAE	10.8	56.0	1.0	15.5	25	6.0	20.0	26.0	30	ED-6
R*O200E4S**	ZS15KAE	14.1	68.0	1.0	19.6	30	10.0	25.0	32.2	40	ED-7
R*O250E4S**	ZS19KAE	16.2	75.0	1.0	22.2	35	10.0	25.0	32.2	45	ED-7
R*O300E4S**	ZS21KAE	20.8	112.0	3.1	30.1	50	12.0	30.0	42.1	60	ED-10
R*O350E4S**	ZS26KAE	21.2	104.0	3.1	30.6	50	12.0	30.0	42.6	60	ED-10
R*O400E4S**	ZS29KAE	23.4	137.0	3.1	33.3	50	12.0	30.0	45.3	60	ED-10
R*O450E4S**	ZS33KAE	23.0	146.0	3.1	32.8	50	12.0	30.0	44.8	60	ED-10
R*O500E4S**	ZS38K4E	28.5	169.0	3.1	39.7	60	12.0	30.0	51.7	60	ED-10

208-230V/1/60 Hz, 200-220V/1/50 Hz[^]

R*O200L4S**	ZF06K4E	12.2	61.0	1.0	-	-	6.0	20.0	26.0	35	ED-6
R*O250L4S**	ZF08K4E	14.7	73.0	1.0	-	-	10.0	25.0	32.0	45	ED-7
R*O300L4S**	ZF09K4E	16.0	88.0	1.0	-	-	10.0	25.0	32.0	45	ED-7
R*O350L4S**	ZF11K4E	18.6	109.0	1.0	-	-	10.0	30.0	38.5	50	ED-10
R*O400L4S**	ZF13K4E	22.4	129.0	3.1	-	-	12.0	30.0	44.0	60	ED-10
R*O500L4S**	ZF15K4E	24.7	169.0	3.1	-	-	12.0	30.0	46.0	60	ED-10

208-230V/3/60 Hz, 200-220V/3/50 Hz

R*O130E4S**	ZS09KAE	7.2	55.4	0.5	15.0	15	4.0	15.0	19.7	20	ED-5
R*O150E4S**	ZS11KAE	9.3	58.0	1.0	15.0	20	6.0	15.0	19.7	25	ED-5
R*O180E4S**	ZS13KAE	8.7	58.0	1.0	15.0	20	6.0	15.0	19.7	25	ED-5
R*O200E4S**	ZS15KAE	9.6	58.0	1.0	15.0	20	10.0	20.0	26.0	30	ED-6
R*O250E4S**	ZS19KAE	12.3	73.0	1.0	17.3	25	10.0	25.0	32.2	35	ED-7
R*O300E4S**	ZS21KAE	13.7	93.0	3.1	21.2	30	12.0	25.0	33.2	45	ED-7
R*O350E4S**	ZS26KAE	13.9	93.0	3.1	21.4	35	12.0	25.0	33.4	45	ED-7
R*O400E4S**	ZS29KAE	18.4	114.0	3.1	27.1	45	12.0	30.0	39.1	50	ED-11
R*O450E4S**	ZS33KAE	20.0	114.0	3.1	29.1	45	12.0	30.0	41.1	60	ED-11
R*O500E4S**	ZS38K4E	19.2	123.0	3.1	28.1	45	12.0	30.0	40.1	50	ED-11
R*O600E4S**	ZS45K4E	21.5	156.0	3.1	30.9	50	12.0	30.0	42.9	60	ED-11
R*O200L4S**	ZF06K4E	8.3	55.0	1.0	-	-	6.0	15.0	19.7	25	ED-5
R*O250L4S**	ZF08K4E	8.7	63.0	1.0	-	-	10.0	20.0	26.0	30	ED-6
R*O300L4S**	ZF09K4E	8.7	77.0	1.0	-	-	10.0	20.0	26.0	30	ED-6
R*O350L4S**	ZF11K4E	10.9	88.0	1.0	-	-	10.0	25.0	32.2	35	ED-7
R*O400L4S**	ZF13K4E	11.9	99.0	3.1	-	-	12.0	25.0	32.2	40	ED-7
R*O500L4S**	ZF15K4E	17.0	123.0	3.1	-	-	12.0	30.0	38.5	50	ED-11
R*O600L4S**	ZF18K4E	19.6	156.0	3.1	-	-	12.0	30.0	40.6	60	ED-11

See notes listed under Scroll 460V/3/60 Hz electrical table on next page.

NEXT-GEN MINICON CONDENSING UNITS

Electrical Data - Scroll

BASE MODEL NUMBER	COMP. MODEL	COMPRESSOR		COND. FAN FLA	AIR DEFROST		MAX. EVAP. FAN AMPS [†]	MAX DEFROST AMPS [†]	ELECTRIC DEFROST		ELECTRIC DEFROST KIT [†]
		RLA	LRA		MCA	MOPD			MCA	MOPD	

460V/3/60 Hz, 380V/3/50 Hz

R*O130E4S**	ZS09KAE	3.4	28.0	0.4	15.0	15	2.0	15.0	19.7	20	ED-17
R*O150E4S**	ZS11KAE	3.8	28.0	0.8	15.0	15	3.0	15.0	19.7	20	ED-17
R*O180E4S**	ZS13KAE	4.3	29.0	0.8	15.0	15	3.0	15.0	19.7	20	ED-17
R*O200E4S**	ZS15KAE	4.8	29.0	0.8	15.0	15	5.0	15.0	19.7	20	ED-17
R*O250E4S**	ZS19KAE	5.8	38.0	0.8	15.0	15	5.0	15.0	19.7	20	ED-17
R*O300E4S**	ZS21KAE	6.2	48.0	2.5	15.0	15	6.0	15.0	19.7	20	ED-17
R*O350E4S**	ZS26KAE	6.2	48.0	2.5	15.0	15	6.0	15.0	19.7	20	ED-17
R*O400E4S**	ZS29KAE	8.4	58.0	2.5	15.0	20	6.0	15.0	20.0	25	ED-17
R*O450E4S**	ZS33KAE	9.0	52.0	2.5	15.0	20	6.0	20.0	26.0	30	ED-18
R*O500E4S**	ZS38K4E	8.7	62.0	2.5	15.0	20	6.0	20.0	26.0	30	ED-18
R*O600E4S**	ZS45K4E	10.3	75.0	2.5	16.3	25	6.0	20.0	26.0	30	ED-18
R*O200L4S**	ZF06K4E	3.8	27.0	0.8	-	-	3.0	15.0	19.7	20	ED-17
R*O250L4S**	ZF08K4E	4.5	31.0	0.8	-	-	5.0	15.0	19.7	20	ED-17
R*O300L4S**	ZF09K4E	4.5	39.0	0.8	-	-	5.0	15.0	19.7	20	ED-17
R*O350L4S**	ZF11K4E	5.8	44.0	0.8	-	-	5.0	15.0	19.7	20	ED-17
R*O400L4S**	ZF13K4E	6.4	49.5	2.5	-	-	6.0	15.0	19.7	20	ED-17
R*O500L4S**	ZF15K4E	8.0	62.0	2.5	-	-	6.0	15.0	19.7	25	ED-17
R*O600L4S**	ZF18K4E	8.0	75.0	2.5	-	-	6.0	15.0	19.7	25	ED-17

* Each asterisk represents a variable character based upon model, voltage, and vintage ordered. See page 4 for nomenclature.

RLA = Rated Load Amps LRA = Locked Rotor Amps MCA = Minimum Circuit Ampacity MOPD = Maximum Overcurrent Protection
MCA includes 1 amp allowance for control circuit requirement.

† Note: Maximum Evap. fan amps and maximum defrost amps are shown to provide ratings when electric defrost is required and is an optional feature. Maximum Amp value used to determine MOPD. Exceeding these values invalidates the listed MOPD and requires a revised calculation. Contact Application Engineering when amp draw requirements deviate from the chart values.

^ R*O600L4S and R*O600E4S are not available in 200-220V/1/50 Hz or 208-230V/1/60 Hz.



Next-Gen MiniCon condensing units are very adaptable and have ample room within the cabinet and control panel for many optional components

R-SERIES

Specifications - All Models

MODEL DATA			CONNECTIONS (IN.)		PUMP DOWN CAPACITY							
MODEL NUMBER	COMP. MODEL	HP	LIQUID	SUCTION	STANDARD RECEIVER [^]				OVERSIZED RECEIVER [^]			
					90% R404A (LBS.)	90% R407A (LBS.)	90% R407C (LBS.)	90% R448/449A (LBS.)	90% R404A (LBS.)	90% R407A (LBS.)	90% R407C (LBS.)	90% R448/449A (LBS.)

Extended Medium Temperature Hermetic

R*H055E44**	RST45C1E	1/2	3/8	5/8	5.9	-	-	-	11.0	-	12.7	11.6
R*H080E44**	RST55C1E	3/4	3/8	5/8	5.9	-	-	-	11.0	-	12.7	11.6
R*H090E44**	RST64C1E	3/4	3/8	5/8	5.9	-	-	-	11.0	-	12.7	11.6
R*H100E44**	RST70C1E	1	3/8	5/8	5.9	-	-	-	11.0	-	12.7	11.6
R*H125E44**	RST97C1E	1-1/4	1/2	7/8	11.0	-	-	-	13.6	-	15.7	14.3
R*H150E44**	CS10K6E	1-1/2	1/2	7/8	11.0	-	-	-	13.6	-	-	14.3
R*H200E44**	CS12K6E	2	1/2	7/8	11.0	-	-	-	13.6	-	-	14.3
R*H250E44**	CS14K6E	2-1/2	1/2	7/8	13.6	-	-	-	20.9	-	-	22.0
R*H300E44**	CS18K6E	3	1/2	7/8	13.6	-	-	-	20.9	-	-	22.0
R*H325E44**	CS20K6E	3	5/8	1-1/8	28.0	-	-	-	37.9	-	-	39.8

Low Temperature Hermetic

R*H100L44**	CF04K6E	1	3/8	5/8	5.9	-	-	-	11.0	-	-	-
R*H150L44**	CF06K6E	1-1/2	3/8	5/8	5.9	-	-	-	11.0	-	-	-
R*H200L44**	CF09K6E	2	3/8	7/8	11.0	-	-	-	13.6	-	-	-
R*H300L44**	CF12K6E	3	3/8	7/8	13.6	-	-	-	20.9	-	-	-

Extended Medium Temperature Scroll

R*O130E4S**	ZS09KAE	1	3/8	5/8	5.9	6.4	6.7	6.1	11.0	12.1	12.7	11.6
R*O150E4S**	ZS11KAE	1-1/4	1/2	7/8	11.0	12.1	12.7	11.6	13.6	15.0	15.7	14.3
R*O180E4S**	ZS13KAE	1-1/2	1/2	7/8	11.0	12.1	12.7	11.6	13.6	15.0	15.7	14.3
R*O200E4S**	ZS15KAE	2	1/2	7/8	13.6	15.0	15.7	14.3	20.9	23.1	24.1	22.0
R*O250E4S**	ZS19KAE	2-1/2	1/2	7/8	13.6	15.0	15.7	14.3	20.9	23.1	24.1	22.0
R*O300E4S**	ZS21KAE	3	5/8	1-1/8	28.0	30.9	32.3	29.4	37.9	41.8	43.7	39.8
R*O350E4S**	ZS26KAE	3-1/2	5/8	1-1/8	28.0	30.9	32.3	29.4	37.9	41.8	43.7	39.8
R*O400E4S**	ZS29KAE	4	5/8	1-1/8	28.0	30.9	32.3	29.4	37.9	41.8	43.7	39.8
R*O450E4S**	ZS33KAE	4-1/2	5/8	1-1/8	28.0	30.9	32.3	29.4	37.9	41.8	43.7	39.8
R*O500E4S**	ZS38K4E	5	5/8	1-1/8	28.0	30.9	32.3	29.4	37.9	41.8	43.7	39.8
R*O600E4S**	ZS45K4E	6	5/8	1-1/8	28.0	30.9	32.3	29.4	37.9	41.8	43.7	39.8

Low Temperature Scroll

R*O200L4S**	ZF06K4E	2	3/8	7/8	11.0	12.1	12.7	11.6	13.6	15.0	15.7	14.3
R*O250L4S**	ZF08K4E	2-1/2	3/8	7/8	13.6	15.0	15.7	14.3	20.9	23.1	24.1	22.0
R*O300L4S**	ZF09K4E	3	3/8	7/8	13.6	15.0	15.7	14.3	20.9	23.1	24.1	22.0
R*O350L4S**	ZF11K4E	3-1/2	3/8	7/8	13.6	15.0	15.7	14.3	20.9	23.1	24.1	22.0
R*O400L4S**	ZF13K4E	4	1/2	1-1/8	28.0	30.9	32.3	29.4	37.9	41.8	43.7	39.8
R*O500L4S**	ZF15K4E	5	1/2	1-1/8	28.0	30.9	32.3	29.4	37.9	41.8	43.7	39.8
R*O600L4S**	ZF18K4E	6	1/2	1-1/8	28.0	30.9	32.3	29.4	37.9	41.8	43.7	39.8

* Each asterisk represents a variable character based upon model, voltage, and vintage ordered. See page 4 for nomenclature.

[^] Sierra models (RVH/RVO) are critical charge units. They do not require additional refrigerant for winter charge and have no auxiliary receiver tank. Liquid line run is a maximum of 50 feet. Liquid line solenoid must be mounted at case or evaporator.

NEXT-GEN MINICON CONDENSING UNITS

Specifications - All Models

MODEL DATA		CABINET SIZE††	FAN QTY.	DIMENSIONS (IN.)			APPROX. SHIP WT. (LBS.)	SOUND DATA dBA†
MODEL NUMBER	COMP. MODEL			D	W	H		

Extended Medium Temperature Hermetic

R*H055E44**	RST45C1E	FM1	1	28-1/4	27-7/8	18-3/4	152	68
R*H080E44**	RST55C1E	FM1	1	28-1/4	27-7/8	18-3/4	156	68
R*H090E44**	RST64C1E	FM1	1	28-1/4	27-7/8	18-3/4	160	68
R*H100E44**	RST70C1E	FM1	1	28-1/4	27-7/8	18-3/4	167	68
R*H125E44**	RST97C1E	FM2	2	28-1/4	39-7/8	18-3/4	195	72
R*H150E44**	CS10K6E	FM2	2	28-1/4	39-7/8	18-3/4	205	72
R*H200E44**	CS12K6E	FM2	2	28-1/4	39-7/8	18-3/4	228	72
R*H250E44**	CS14K6E	FM3	2	28-1/4	39-7/8	21-1/4	235	72
R*H300E44**	CS18K6E	FM3	2	28-1/4	39-7/8	21-1/4	253	73
R*H325E44**	CS20K6E	FM4	1	33	43-7/8	35	273	73

Low Temperature Hermetic

R*H100L44**	CF04K6E	FM1	1	28-1/4	27-7/8	18-3/4	195	74
R*H150L44**	CF06K6E	FM1	1	28-1/4	27-7/8	18-3/4	195	74
R*H200L44**	CF09K6E	FM2	2	28-1/4	39-7/8	18-3/4	243	75
R*H300L44**	CF12K6E	FM3	2	28-1/4	39-7/8	21-1/4	255	77

Extended Medium Temperature Scroll

R*O130E4S**	ZS09KAE	FM1	1	28-1/4	27-7/8	18-3/4	195	70
R*O150E4S**	ZS11KAE	FM2	2	28-1/4	39-7/8	18-3/4	205	71
R*O180E4S**	ZS13KAE	FM2	2	28-1/4	39-7/8	18-3/4	210	71
R*O200E4S**	ZS15KAE	FM3	2	28-1/4	39-7/8	21-1/4	215	71
R*O250E4S**	ZS19KAE	FM3	2	28-1/4	39-7/8	21-1/4	230	72
R*O300E4S**	ZS21KAE	FM4	1	33	43-7/8	35	305	72
R*O350E4S**	ZS26KAE	FM4	1	33	43-7/8	35	325	72
R*O400E4S**	ZS29KAE	FM4	1	33	43-7/8	35	352	74
R*O450E4S**	ZS33KAE	FM4	1	33	43-7/8	35	375	74
R*O500E4S**	ZS38K4E	FM4	1	33	43-7/8	35	383	74
R*O600E4S**	ZS45K4E	FM4	1	33	43-7/8	35	405	76

Low Temperature Scroll

R*O200L4S**	ZF06K4E	FM2	2	28-1/4	39-7/8	18-3/4	230	71
R*O250L4S**	ZF08K4E	FM3	2	28-1/4	39-7/8	21-1/4	240	73
R*O300L4S**	ZF09K4E	FM3	2	28-1/4	39-7/8	21-1/4	245	73
R*O350L4S**	ZF11K4E	FM3	2	28-1/4	39-7/8	21-1/4	255	73
R*O400L4S**	ZF13K4E	FM4	1	33	43-7/8	35	352	73
R*O500L4S**	ZF15K4E	FM4	1	33	43-7/8	35	367	74
R*O600L4S**	ZF18K4E	FM4	1	33	43-7/8	35	383	76

* Each asterisk represents a variable character based upon model, voltage, and vintage ordered. See page 4 for nomenclature.

† Estimated dBA values at 10 feet from the unit. Correction factors: Deduct 6 dBA for 20 to 40 feet, 12 dBA @ 40 to 60 feet. Ratings at the outlet of the discharge air. The actual measurements may vary depending upon installation variables. Environmental factors may have a significant influence on this data.

†† See pages 22-23 for associated drawings.



APPLICATIONS

R-SERIES

Physical Dimensions - All Models

FM1

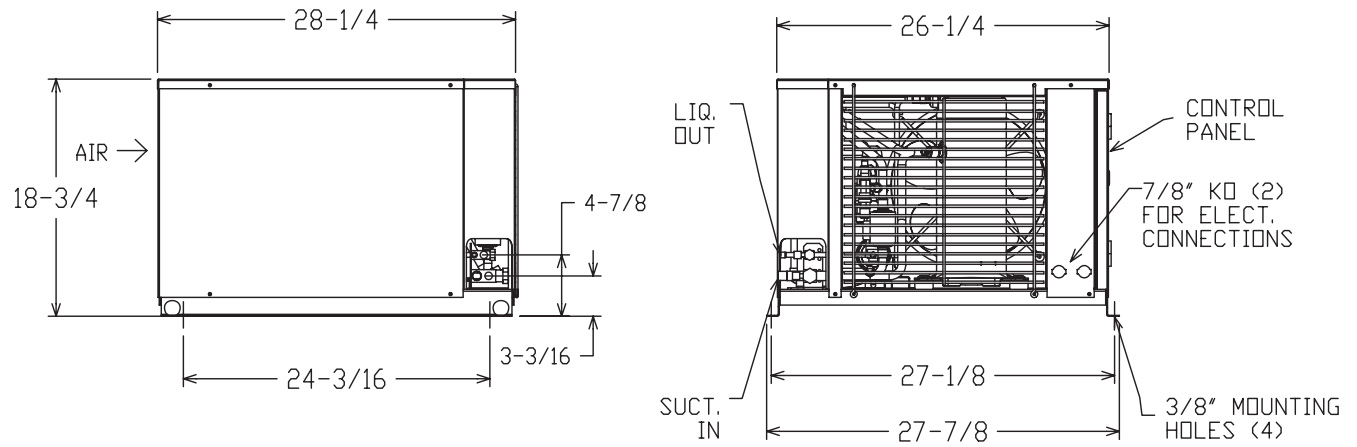

FM2

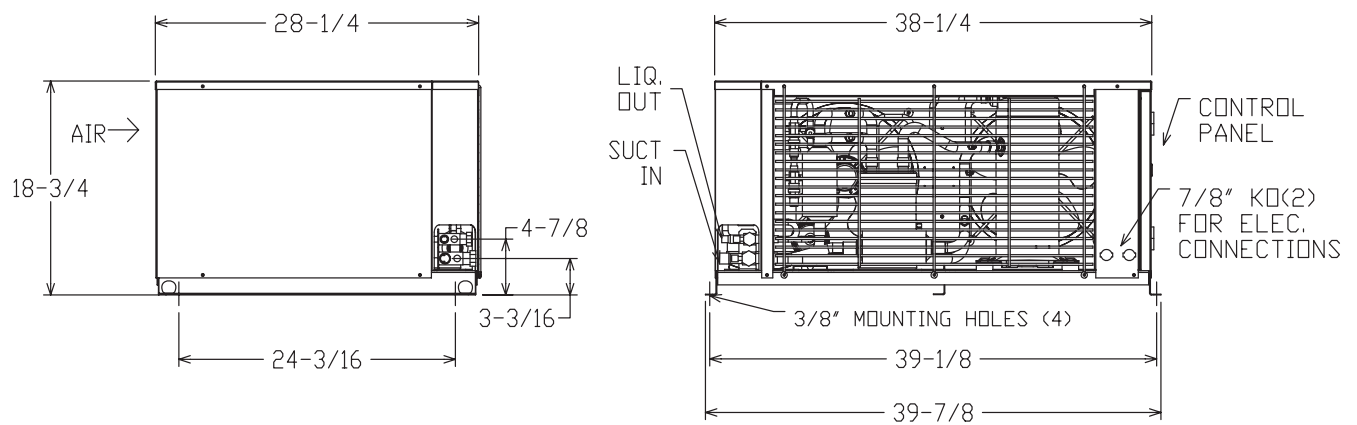

* Dimensions are in inches.

NEXT-GEN MINICON CONDENSING UNITS

Physical Dimensions - All Models

FM3

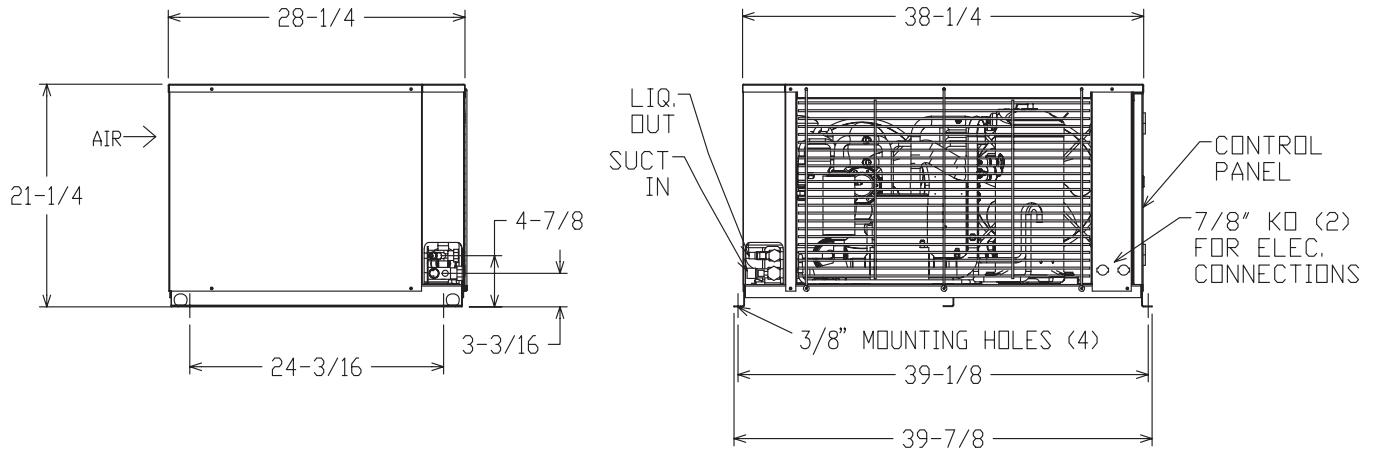

FM4

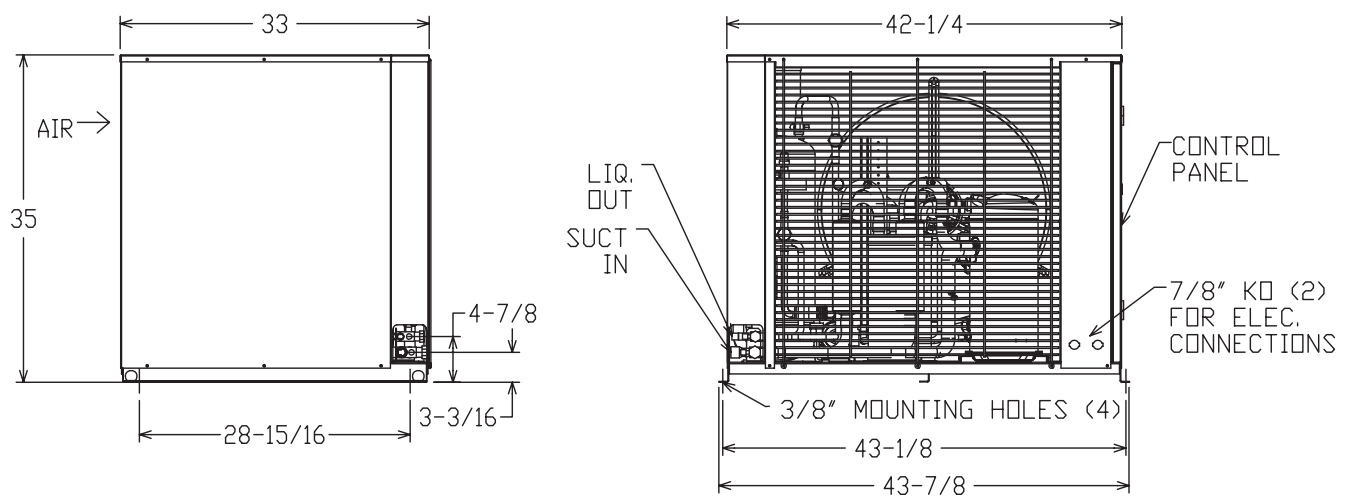

* Dimensions are in inches.

R-SERIES

Due to continuing product development, specifications are subject to change without notice.

