



PRODUCT INFORMATION NOTICE

Subject: SLOPED DRAIN PAN HEAVY-DUTY AND WAREHOUSE EVAPORATORS

By: Nicholas Smith
Issue: Model Redesign

PIN #: TCO-50
Date: 08-29-2023

All,

Due to continuous product development and customer feedback the heavy-duty and warehouse evaporators have been redesigned to include a sloped drain pan and air dam, and the sloped hanging brackets will no longer be used.

This change will affect all brands, voltages and vintages of all warehouse and heavy-duty evaporators.

All orders submitted and entered before 09/18/2023 will be manufactured using the sloped hanging brackets and all orders submitted on or after 09/18/2023 will be manufactured using the sloped drain pan, air dam and level hanging brackets.

Note: Overall unit height increases approximately 2" on the drain connection end.

Note: Updated IOM's, catalogs, submittals and RapidSpec will be available online on or before 09/18/2023.

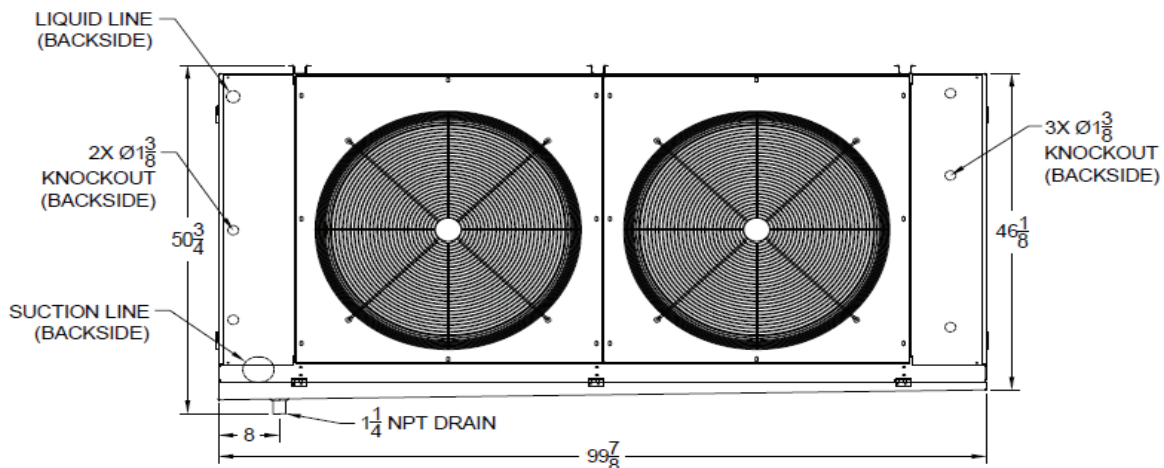

Action:

Please ensure any impacted customers are aware of the new construction. All orders submitted on or after 09/18/2023 will be manufactured to the new design.

Nicholas Smith

Product Manager, Evaporators and Condensers